

High School Flip Book

COMMON CORE

STATE STANDARDS FOR

Mathematics

This document is intended to show the connections of the Standards for Mathematical Practices to the content standards in each conceptual category and provide information and instructional strategies that further describe the standards. The “Flip Book” is designed as a resource tool to assist teachers in deepening their understanding of what each standard means in terms of what students must know and be able to do. It outlines only a *sample* of instructional strategies and examples. Links to conceptual categories and specific standards in the document can be accessed from [page 5 Mathematics Standards for High School](#). **Note: To return to a conceptual category overview page from a standard click on the domain abbreviation.**

Only explanations and descriptions of the high school standards that are designated as those that all students should study in order to be college-and –career ready are described in this flip book. CCSS identified with a (+) that contain additional mathematics that students should learn in order to take advanced courses such as calculus, advanced statistics or discrete mathematics are not included in this document.

Resources Used: Common Core State Standards for Mathematics <http://www.ksde.org/Default.aspx?tabid=4754>

Arizona Department of Education – *Academic Content Standards* <http://www.azed.gov/standards/practices/mathematics-standards/>

Ohio Department of Education- *Mathematics Model Curriculum*

<http://education.ohio.gov/GD/Templates/Pages/ODE/ODEDetail.aspx?page=3&TopicRelationID=1704&ContentID=83475&Content=12691>

North Carolina Department of Education – *Common Core Instructional Support Tools*

<http://www.dpi.state.nc.us/acre/standards/common-core-tools/#unmath>

Illustrative Mathematics <http://illustrativemathematics.org/>

Smarter Balanced Assessment Consortium – *Mathematics Content Specifications*

<http://www.smarterbalanced.org/smarter-balanced-assessments/#item>

Printing/Construction Directions:

This document is formatted for double sided printing (some pages are intentionally left blank).

Print on cardstock – both sides – flip pages on short edge. Cut the bottom off of this top cover to reveal the tabs for subsequent pages. Cut the tabs on each page starting with page 1.

Staple or bind the top of all pages to complete the flip book.

1. Make sense of problems and persevere in solving them.

Mathematically proficient students interpret and make meaning of the problem looking for starting points. They analyze what is given to find the meaning of the problem. They plan a solution pathway instead of jumping to a solution. These students can monitor their progress and change the approach if necessary. They see relationships between various representations. They relate current situations to concepts or skills previously learned and connect mathematical ideas to one another. In grade 6, students solve problems involving ratios and rates and discuss how they solved them. Students solve real world problems through the application of algebraic and geometric concepts. Students seek the meaning of a problem and look for efficient ways to represent and solve it. They may check their thinking by asking themselves, “What is the most efficient way to solve the problem?”, “Does this make sense?”, and “Can I solve the problem in a different way?”

2. Reason abstractly and quantitatively.

Mathematically proficient students make sense of quantities and their relationships. They are able to decontextualize (represent a situation symbolically and manipulate the symbols) and contextualize (make meaning of the symbols in a problem) quantitative relationships. Younger students recognize that a number represents a specific quantity. They connect the quantity to written symbols. Quantitative reasoning entails creating a representation of a problem while attending to the meanings of the quantities, not just how to compute them. In grade 6, students represent a wide variety of real world contexts through the use of real numbers and variables in mathematical expressions, equations, and inequalities. Students contextualize to understand the meaning of the number or variable as related to the problem and decontextualize to manipulate symbolic representations by applying properties of operations.

3. Construct viable arguments and critique the reasoning of others.

Mathematically proficient students analyze problems and use stated mathematical assumptions, definitions, and established results in constructing arguments. First graders construct arguments using concrete referents, such as objects, pictures, drawings, and actions. In grade 6, students construct arguments using verbal or written explanations accompanied by expressions, equations, inequalities, models, and graphs, tables, and other data displays (i.e. box plots, dot plots, histograms, etc.). They further refine their mathematical communication skills through mathematical discussions in which they critically evaluate their own thinking and the thinking of other students. They pose questions like “How did you get that?”, “Why is that true?” “Does that always work?” They explain their thinking to others and respond to others’ thinking.

4. Model with mathematics.

Mathematically proficient students understand that models are a way to reason quantitatively and abstractly (able to decontextualize and contextualize). In grade 6, students model problem situations symbolically, graphically, tabularly, and contextually. Students form expressions, equations, or inequalities from real world contexts and connect symbolic and graphical representations. Students begin to explore covariance and represent two quantities simultaneously. Students use number lines to compare numbers and represent inequalities. They use measures of center and variability and data displays (i.e. box plots and histograms) to draw inferences about and make comparisons between data sets. Students need many opportunities to connect and explain the connections between the different representations. They should be able to use all of these representations as appropriate to a problem context.

Mathematical Practice Standards (MP) summary of each standard

5. Use appropriate tools strategically.

Mathematically proficient students use available tools recognizing the strengths and limitations of each. Students consider available tools (including estimation and technology) when solving a mathematical problem and decide when certain tools might be helpful. For instance, students in grade 6 may decide to represent similar data sets using dot plots with the same scale to visually compare the center and variability of the data. Additionally, students might use physical objects or applets to construct nets and calculate the surface area of three-dimensional figures.

6. Attend to precision.

Mathematically proficient students communicate precisely with others and try to use clear mathematical language when discussing their reasoning. They understand meanings of symbols used in mathematics and can label quantities appropriately. In grade 6, students continue to refine their mathematical communication skills by using clear and precise language in their discussions with others and in their own reasoning. Students use appropriate terminology when referring to rates, ratios, geometric figures, data displays, and components of expressions, equations or inequalities.

7. Look for and make use of structure. (Deductive Reasoning)

Mathematically proficient students apply general mathematical rules to specific situations. They look for the overall structure and patterns in mathematics. Students routinely seek patterns or structures to model and solve problems. For instance, students recognize patterns that exist in ratio tables recognizing both the additive and multiplicative properties. Students apply properties to generate equivalent expressions (i.e. $6 + 2x = 2(3 + x)$ by distributive property) and solve equations (i.e. $2c + 3 = 15$, $2c = 12$ by subtraction property of equality; $c=6$ by division property of equality). Students compose and decompose two- and three-dimensional figures to solve real world problems involving area and volume.

8. Look for and express regularity in repeated reasoning. (Inductive Reasoning)

Mathematically proficient students see repeated calculations and look for generalizations and shortcuts. In grade 6, students use repeated reasoning to understand algorithms and make generalizations about patterns. During multiple opportunities to solve and model problems, they may notice that $a/b \div c/d = ad/bc$ and construct other examples and models that confirm their generalization. Students connect place value and their prior work with operations to understand algorithms to fluently divide multi-digit numbers and perform all operations with multi-digit decimals. Students informally begin to make connections between covariance, rates, and representations showing the relationships between quantities.

Summary of Standards for Mathematical Practice	Questions to Develop Mathematical Thinking
<p>1. Make sense of problems and persevere in solving them.</p> <p>Interpret and make meaning of the problem looking for starting points. Analyze what is given to explain to themselves the meaning of the problem.</p> <p>Plan a solution pathway instead of jumping to a solution.</p> <p>Can monitor their progress and change the approach if necessary.</p> <p>See relationships between various representations.</p> <p>Relate current situations to concepts or skills previously learned and connect mathematical ideas to one another.</p> <p>Can understand various approaches to solutions.</p> <p>Continually ask themselves; “Does this make sense?”</p>	<p>How would you describe the problem in your own words?</p> <p>How would you describe what you are trying to find?</p> <p>What do you notice about...?</p> <p>What information is given in the problem?</p> <p>Describe the relationship between the quantities.</p> <p>Describe what you have already tried.</p> <p>What might you change?</p> <p>Talk me through the steps you’ve used to this point.</p> <p>What steps in the process are you most confident about?</p> <p>What are some other strategies you might try?</p> <p>What are some other problems that are similar to this one?</p> <p>How might you use one of your previous problems to help you begin?</p> <p>How else might you organize...represent... show...?</p>
<p>2. Reason abstractly and quantitatively.</p> <p>Make sense of quantities and their relationships.</p> <p>Are able to decontextualize (represent a situation symbolically and manipulate the symbols) and contextualize (make meaning of the symbols in a problem) quantitative relationships.</p> <p>Understand the meaning of quantities and are flexible in the use of operations and their properties.</p> <p>Create a logical representation of the problem.</p> <p>Attends to the meaning of quantities, not just how to compute them.</p>	<p>What do the numbers used in the problem represent?</p> <p>What is the relationship of the quantities?</p> <p>How is _____ related to _____?</p> <p>What is the relationship between _____ and _____?</p> <p>What does _____ mean to you? (e.g. symbol, quantity, diagram)</p> <p>What properties might we use to find a solution?</p> <p>How did you decide in this task that you needed to use...?</p> <p>Could we have used another operation or property to solve this task? Why or why not?</p>
<p>3. Construct viable arguments and critique the reasoning of others.</p> <p>Analyze problems and use stated mathematical assumptions, definitions, and established results in constructing arguments.</p> <p>Justify conclusions with mathematical ideas.</p> <p>Listen to the arguments of others and ask useful questions to determine if an argument makes sense.</p> <p>Ask clarifying questions or suggest ideas to improve/revise the argument.</p> <p>Compare two arguments and determine correct or flawed logic.</p>	<p>What mathematical evidence would support your solution?</p> <p>How can we be sure that...? / How could you prove that...?</p> <p>Will it still work if...?</p> <p>What were you considering when...?</p> <p>How did you decide to try that strategy?</p> <p>How did you test whether your approach worked?</p> <p>How did you decide what the problem was asking you to find? (What was unknown?)</p> <p>Did you try a method that did not work? Why didn’t it work?</p> <p>Would it ever work? Why or why not?</p> <p>What is the same and what is different about...?</p> <p>How could you demonstrate a counter-example?</p>
<p>4. Model with mathematics.</p> <p>Understand this is a way to reason quantitatively and abstractly (able to decontextualize and contextualize).</p> <p>Apply the math they know to solve problems in everyday life.</p> <p>Are able to simplify a complex problem and identify important quantities to look at relationships.</p> <p>Represent mathematics to describe a situation either with an equation or a diagram and interpret the results of a mathematical situation.</p> <p>Reflect on whether the results make sense, possibly improving or revising the model.</p> <p>Ask themselves, “How can I represent this mathematically?”</p>	<p>What number model could you construct to represent the problem?</p> <p>What are some ways to represent the quantities?</p> <p>What’s an equation or expression that matches the diagram..., number line..., chart..., table...?</p> <p>Where did you see one of the quantities in the task in your equation or expression?</p> <p>Would it help to create a diagram, graph, table...?</p> <p>What are some ways to visually represent...?</p> <p>What formula might apply in this situation?</p>

Summary of Standards for Mathematical Practice	Questions to Develop Mathematical Thinking
<p>5. Use appropriate tools strategically.</p> <p>Use available tools recognizing the strengths and limitations of each.</p> <p>Use estimation and other mathematical knowledge to detect possible errors.</p> <p>Identify relevant external mathematical resources to pose and solve problems.</p> <p>Use technological tools to deepen their understanding of mathematics.</p>	<p>What mathematical tools could we use to visualize and represent the situation?</p> <p>What information do you have?</p> <p>What do you know that is not stated in the problem?</p> <p>What approach are you considering trying first?</p> <p>What estimate did you make for the solution?</p> <p>In this situation would it be helpful to use...a graph..., number line..., ruler..., diagram..., calculator..., manipulative?</p> <p>Why was it helpful to use...?</p> <p>What can using a _____ show us, that _____ may not?</p> <p>In what situations might it be more informative or helpful to use...?</p>
<p>6. Attend to precision.</p> <p>Communicate precisely with others and try to use clear mathematical language when discussing their reasoning.</p> <p>Understand meanings of symbols used in mathematics and can label quantities appropriately.</p> <p>Express numerical answers with a degree of precision appropriate for the problem context.</p> <p>Calculate efficiently and accurately.</p>	<p>What mathematical terms apply in this situation?</p> <p>How did you know your solution was reasonable?</p> <p>Explain how you might show that your solution answers the problem.</p> <p>Is there a more efficient strategy?</p> <p>How are you showing the meaning of the quantities?</p> <p>What symbols or mathematical notations are important in this problem?</p> <p>What mathematical language..., definitions..., properties can you use to explain...?</p> <p>How could you test your solution to see if it answers the problem?</p>
<p>7. Look for and make use of structure.</p> <p>Apply general mathematical rules to specific situations.</p> <p>Look for the overall structure and patterns in mathematics.</p> <p>See complicated things as single objects or as being composed of several objects.</p>	<p>What observations do you make about...?</p> <p>What do you notice when...?</p> <p>What parts of the problem might you eliminate..., simplify...?</p> <p>What patterns do you find in...?</p> <p>How do you know if something is a pattern?</p> <p>What ideas that we have learned before were useful in solving this problem?</p> <p>What are some other problems that are similar to this one?</p> <p>How does this relate to...?</p> <p>In what ways does this problem connect to other mathematical concepts?</p>
<p>8. Look for and express regularity in repeated reasoning.</p> <p>See repeated calculations and look for generalizations and shortcuts.</p> <p>See the overall process of the problem and still attend to the details.</p> <p>Understand the broader application of patterns and see the structure in similar situations.</p> <p>Continually evaluate the reasonableness of their intermediate results.</p>	<p>Will the same strategy work in other situations?</p> <p>Is this always true, sometimes true or never true?</p> <p>How would we prove that...?</p> <p>What do you notice about...?</p> <p>What is happening in this situation?</p> <p>What would happen if...?</p> <p>Is there a mathematical rule for...?</p> <p>What predictions or generalizations can this pattern support?</p> <p>What mathematical consistencies do you notice ?</p>

Mathematics Standards for High School

The high school standards specify the mathematics that all students should study in order to be college and career ready. Additional mathematics that students should learn in fourth credit courses or advanced courses such as calculus, advanced statistics, or discrete mathematics is indicated by (+).

All standards *without* a (+) symbol should be in the common mathematics curriculum for all college and career ready students. Standards with a (+) symbol may also appear in courses intended for all students.

The high school standards are listed in conceptual categories: **Number and Quantity**, **Algebra**, **Functions**, **Modeling**, **Geometry**, and **Statistics and Probability**. Conceptual categories portray a coherent view of high school mathematics; a student's work with functions, for example, crosses a number of traditional course boundaries, potentially up through and including calculus.

Modeling is best interpreted not as a collection of isolated topics but in relation to other standards. Making mathematical models is a Standard for Mathematical Practice, and specific modeling standards appear throughout the high school standards indicated by a star symbol (★).

Number and Quantity

- [The Real Number System \(N-RN\)](#)
- [Quantities \(N-Q\)](#) ★
- [The Complex Number System \(N-CN\)](#)
- [Vector and Matrix Quantities \(N-VM\)](#) +

Algebra

- [Seeing Structure in Expressions \(A-SSE\)](#)
- [Arithmetic with Polynomials and Rational Expressions \(A-APR\)](#)
- [Creating Equations \(A-CED\)](#) ★
- [Reasoning with Equations and Inequalities \(A-REI\)](#)

Functions

- [Interpreting Functions \(F-IF\)](#)
- [Building Functions \(F-BF\)](#)
- [Linear, Quadratic, and Exponential Models \(F-LE\)](#) ★
- [Trigonometric Functions \(F-TF\)](#)

Modeling

Geometry

- [Congruence \(G-CO\)](#)
- [Similarity, Right Triangles, and Trigonometry \(G-SRT\)](#)
- [Circles \(G-C\)](#)
- [Expressing Geometric Properties with Equations \(G-GPE\)](#)
- [Geometric Measurement and Dimension \(G-GMD\)](#)
- [Modeling with Geometry \(G-MG\)](#) ★

Statistics and Probability ★

- [Interpreting Categorical and Quantitative Data \(S-ID\)](#)
- [Making Inferences and Justifying Conclusions \(S-IC\)](#)
- [Conditional Probability and the Rules of Probability \(S-CP\)](#)
- [Using Probability to Make Decisions \(S-MD\)](#) +

Conceptual Category Modeling

[\(RETURN TO PG. 5\)](#)

Modeling links classroom mathematics and statistics to everyday life, work, and decision-making. Modeling is the process of choosing and using appropriate mathematics and statistics to analyze empirical situations, to understand them better, and to improve decisions. Quantities and their relationships in physical, economic, public policy, social, and everyday situations can be modeled using mathematical and statistical methods. When making mathematical models, technology is valuable for varying assumptions, exploring consequences, and comparing predictions with data.

A model can be very simple, such as writing total cost as a product of unit price and number bought, or using a geometric shape to describe a physical object like a coin. Even such simple models involve making choices. It is up to us whether to model a coin as a three-dimensional cylinder, or whether a two-dimensional disk works well enough for our purposes. Other situations—modeling a delivery route, a production schedule, or a comparison of loan amortizations—need more elaborate models that use other tools from the mathematical sciences. Real-world situations are not organized and labeled for analysis; formulating tractable models, representing such models, and analyzing them is appropriately a creative process. Like every such process, this depends on acquired expertise as well as creativity.

Some examples of such situations might include:

- Estimating how much water and food is needed for emergency relief in a devastated city of 3 million people, and how it might be distributed.
- Planning a table tennis tournament for 7 players at a club with 4 tables, where each player plays against each other player.
- Designing the layout of the stalls in a school fair so as to raise as much money as possible.
- Analyzing stopping distance for a car.
- Modeling savings account balance, bacterial colony growth, or investment growth.
- Engaging in critical path analysis, e.g., applied to turnaround of an aircraft at an airport.
- Analyzing risk in situations such as extreme sports, pandemics, and terrorism.
- Relating population statistics to individual predictions.

In situations like these, the models devised depend on a number of factors: How precise an answer do we want or need? What aspects of the situation do we most need to understand, control, or optimize? What resources of time and tools do we have? The range of models that we can create and analyze is also constrained by the limitations of our mathematical, statistical, and technical skills, and our ability to recognize significant variables and relationships among them. Diagrams of various kinds, spreadsheets and other technology, and algebra are powerful tools for understanding and solving problems drawn from different types of real-world situations.

One of the insights provided by mathematical modeling is that essentially the same mathematical or statistical structure can sometimes model seemingly different situations. Models can also shed light on the mathematical structures themselves, for example, as when a model of bacterial growth makes more vivid the explosive growth of the exponential function.

Continued on next page

The basic modeling cycle is summarized in the diagram. It involves:

- (1) identifying variables in the situation and selecting those that represent essential features,
- (2) formulating a model by creating and selecting geometric, graphical, tabular, algebraic, or statistical representations that describe relationships between the variables,
- (3) analyzing and performing operations on these relationships to draw conclusions,
- (4) interpreting the results of the mathematics in terms of the original situation,
- (5) validating the conclusions by comparing them with the situation, and then either improving the model or, if it is acceptable,
- (6) reporting on the conclusions and the reasoning behind them. Choices, assumptions, and approximations are present throughout this cycle.

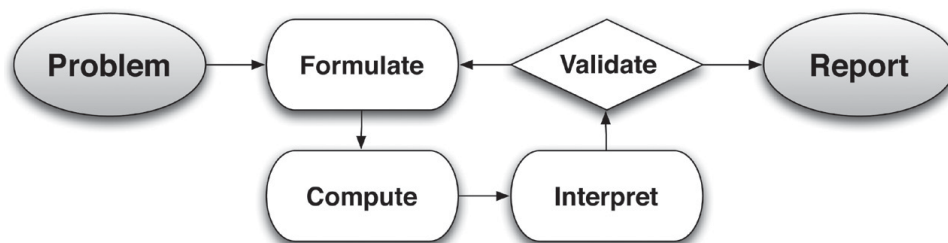

In descriptive modeling, a model simply describes the phenomena or summarizes them in a compact form. Graphs of observations are a familiar descriptive model—for example, graphs of global temperature and atmospheric CO₂ over time.

Analytic modeling seeks to explain data on the basis of deeper theoretical ideas, albeit with parameters that are empirically based; for example, exponential growth of bacterial colonies (until cut-off mechanisms such as pollution or starvation intervene) follows from a constant reproduction rate. Functions are an important tool for analyzing such problems.

Graphing utilities, spreadsheets, computer algebra systems, and dynamic geometry software are powerful tools that can be used to model purely mathematical phenomena (e.g., the behavior of polynomials) as well as physical phenomena.

Modeling Standards *Modeling is best interpreted not as a collection of isolated topics but rather in relation to other standards. Making mathematical models is a Standard for Mathematical Practice, and specific modeling standards appear throughout the high school standards indicated by a star symbol (★).*

Conceptual Category Number and Quantity

Numbers and Number Systems. During the years from kindergarten to eighth grade, students must repeatedly extend their conception of number. At first, “number” means “counting number”: 1, 2, 3.... Soon after that, 0 is used to represent “none” and the whole numbers are formed by the counting numbers together with zero. The next extension is fractions. At first, fractions are barely numbers and tied strongly to pictorial representations. Yet by the time students understand division of fractions, they have a strong concept of fractions as numbers and have connected them, via their decimal representations, with the base-ten system used to represent the whole numbers. During middle school, fractions are augmented by negative fractions to form the rational numbers. In Grade 8, students extend this system once more, augmenting the rational numbers with the irrational numbers to form the real numbers. In high school, students will be exposed to yet another extension of number, when the real numbers are augmented by the imaginary numbers to form the complex numbers.

With each extension of number, the meanings of addition, subtraction, multiplication, and division are extended. In each new number system—integers, rational numbers, real numbers, and complex numbers—the four operations stay the same in two important ways: They have the commutative, associative, and distributive properties and their new meanings are consistent with their previous meanings.

Extending the properties of whole-number exponents leads to new and productive notation. For example, properties of whole-number exponents suggest that $(5^{1/3})^3$ should be $5^{(1/3)3} = 5^1 = 5$ and that $5^{1/3}$ should be the cube root of 5.

Calculators, spreadsheets, and computer algebra systems can provide ways for students to become better acquainted with these new number systems and their notation. They can be used to generate data for numerical experiments, to help understand the workings of matrix, vector, and complex number algebra, and to experiment with non-integer exponents.

Quantities. In real world problems, the answers are usually not numbers but quantities: numbers with units, which involves measurement. In their work in measurement up through Grade 8, students primarily measure commonly used attributes such as length, area, and volume. In high school, students encounter a wider variety of units in modeling, e.g., acceleration, currency conversions, derived quantities such as person-hours and heating degree days, social science rates such as per-capita income, and rates in everyday life such as points scored per game or batting averages. They also encounter novel situations in which they themselves must conceive the attributes of interest. For example, to find a good measure of overall highway safety, they might propose measures such as fatalities per year, fatalities per year per driver, or fatalities per vehicle-mile traveled. Such a conceptual process is sometimes called quantification. Quantification is important for science, as when surface area suddenly “stands out” as an important variable in evaporation. Quantification is also important for companies, which must conceptualize relevant attributes and create or choose suitable measures for them.

Number and Quantity Standards Overview

Note: The standards identified with a (+) contain additional mathematics that students should learn in order to take advanced courses such as calculus, advanced statistics or discrete mathematics that go beyond the mathematics that all students should study in order to be college- and career-ready. Explanations and examples of these standards are not included in this document.

Modeling Standards: *Specific modeling standards appear throughout the high school standards indicated by a star symbol (★).*

[\(RETURN TO PG. 5\)](#)

The Real Number System (N-RN)

- *Extend the properties of exponents to rational exponents.*

[N.RN.1](#) [N.RN.2](#)

- *Use properties of rational and irrational numbers.*

[N.RN.3](#)

Quantities (★) (N-Q)

- *Reason quantitatively and use units to solve problems.*

[N.Q.1 \(★\)](#) [N.Q.2 \(★\)](#) [N.Q.3 \(★\)](#)

The Complex Number System (N-CN)

- *Perform arithmetic operations with complex numbers.*

[N.CN.1](#) [N.CN.2](#) N.CN.3 (+)

- *Represent complex numbers and their operations on the complex plane. (+)*

N.CN.4 (+) N.CN.5 (+) N.CN.6 (+)

- *Use complex numbers in polynomial identities and equations.*

[N.CN.7](#) N.CN.8 (+) N.CN.9 (+)

Vector and Matrix Quantities (+) (N-VM)

The standards in this domain go beyond the mathematics that all students should study in order to be college- and career-ready. The clusters and standards listed are not included in this document.

- *Represent and model with vector quantities.*

N.VM.1 N.VM.2 N.VM.3

- *Perform operations on vectors.*

N.VM.4 N.VM.5

- *Perform operations on matrices and use matrices in applications.*

N.VM.6 N.VM.7 N.VM.8 N.VM.9 N.VM.10 N.VM.11 N.VM.12

Number and Quantity: The Real Number System [\(N-RN\)](#)

Cluster: *Extend the properties of exponents to rational exponents.*

Standard: N.RN.1 Explain how the definition of the meaning of rational exponents follows from extending the properties of integer exponents to those values, allowing for a notation for radicals in terms of rational exponents. For example, we define $5^{1/3}$ to be the cube root of 5 because we want $(5^{1/3})^3 = 5^{(1/3)3}$ to hold, so $(5^{1/3})^3$ must equal 5.

Suggested Standards for Mathematical Practice (MP):

MP.2 Reason abstractly and quantitatively.

MP.7 Look for and make use of structure.

MP.3 Construct viable arguments and critique the reasoning of others.

Connections: N.RN.1-2

Integer exponents (both positive and negative) and radicals were studied in Grade 8. In this cluster, students expand the concept of exponent to include fractional exponents and make a connection to radicals. In more advanced courses, rational exponents will be extended to irrational exponents by means of exponential and logarithmic functions. For example, the definitions for integer and rational exponents will allow for the next step a definition of irrational exponents, such as 2^{2^2} or $2^{1.414213\dots}$ and then a new class of functions – exponential functions of the form $f(x) = b^x$ where $b \neq 1$, $b > 0$. The domain of this class of functions (the x values) is all real numbers (rational and irrational) and the range is the set of all positive real numbers.)

Explanations and Examples: N.RN.1

Understand that the denominator of the rational exponent is the root index and the numerator is the exponent of the radicand. For example, $5^{1/2} = \sqrt{5}$

Students extend the properties of exponents to justify that $(5^{1/2})^2 = 5$

Example Task:

The goal of this task is to develop an understanding of why rational exponents are defined as they are (N-RN.1), however it also raises important issues about distinguishing between linear and exponential behavior (F-LE.1c) and it requires students to create an equation to model a context (A-CED.2)

- A biology student is studying bacterial growth. She was surprised to find that the population of the bacteria doubled every hour.

a. Complete the following table and plot the data.

Hours into study	0	1	2	3	4
Population (thousands)	4				

- b. Write an equation for P , the population of the bacteria, as a function of time, t , and verify that it produces correct populations for $t = 1, 2, 3$, and 4.

Continued on next page

Explanations and Examples: N.RN.1

- c. The student conducting the study wants to create a table with more entries; specifically, she wants to fill in the population at each half hour. However, she forgot to make these measurements so she wants to estimate the values.

Instead she notes that the population increases by the same factor each hour, and reasons that this property should hold over each half-hour interval as well. Fill in the part of the below table that you've already computed, and decide what constant factor she should multiply the population by each half hour in order to produce consistent results. Use this multiplier to complete the table:

Hours into study	0	$\frac{1}{2}$	1	$\frac{3}{2}$	2	$\frac{5}{2}$	3
Population (thousands)	4						

- d. What if the student wanted to estimate the population every 20 minutes instead of every 30 minutes. What multiplier would be necessary to be consistent with the population doubling every hour? Use this multiplier to complete the following table:

Hours into study	0	$\frac{1}{3}$	$\frac{2}{3}$	1	$\frac{4}{3}$	$\frac{5}{3}$	2
Population (thousands)	4						

- e. Use the population context to explain why it makes sense that we define $2^{\frac{1}{2}}$ to be $\sqrt{2}$ and $2^{\frac{1}{3}}$ as $\sqrt[3]{2}$.

- f. Another student working on the bacteria population problem makes the following claim:

If the population doubles in 1 hour, then half that growth occurs in the first half-hour and the other half occurs in the second half-hour. So for example, we can find the population at $t = \frac{1}{2}$ by finding the average of the populations at $t = 0$ and $t = 1$.

Comment on this idea. How does it compare to the multipliers generated in the previous problems? For what kind of function would this reasoning work?

Solution:

a.

Hours into study	0	1	2	3	4
Population (thousands)	4	8	16	32	64

Solution continued on next page

Explanations and Examples: N.RN.1

- a. Students would be expected to find these values by repeatedly multiplying by 2. The plot below consists of the exponential function $P(t) = 4 \cdot 2^t$ which students will derive in the next part. The plot of the data alone would consist of the 5 blue points.

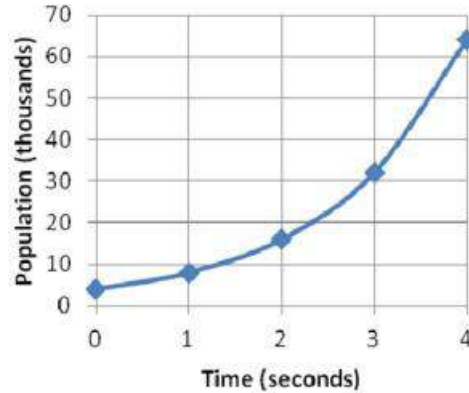

- b. The equation is $P = 4(2)^t$, since as we tallied above via repeated multiplication, we have $4(2)^1 = 8$, $4(2)^2 = 16$, $4(2)^3 = 32$, $4(2)^4 = 64$, etc.

c.

Hours into study	0	$\frac{1}{2}$	1	$\frac{3}{2}$	2	$\frac{5}{2}$	3
Population (thousands)	4	5.657	8	11.314	16	22.627	32

Let x be the multiplier for the half-hour time interval. Then since going forward a full hour in time has the effect of multiplying the population by x^2 , we must have $x^2 = 2$, and so the student needs to multiply by $\sqrt{2}$ every half hour.

d.

Hours into study	0	$\frac{1}{3}$	$\frac{2}{3}$	1	$\frac{4}{3}$	$\frac{5}{3}$	2
Population (thousands)	4	5.010	6.350	8	10.079	12.699	16

Similarly, since waiting three 20-minute intervals should double the population, the new multiplier has to satisfy $x \cdot x \cdot x = 2$, which gives $x^3 = 2$. So you would need to multiply by $\sqrt[3]{2}$ every 20 minutes to have the effect of doubling every hour.

- e. We already know that the equation for population is $P = 4(2)^t$ when t is a natural number. Given this, it's reasonable to use the expression $P(\frac{1}{2}) = 4(2)^{\frac{1}{2}}$ to *define* $\sqrt{2}$. However, we reasoned above that $P(\frac{1}{2}) = 4 \cdot \sqrt{2}$, and equating the two gives $2^{\frac{1}{2}} = \sqrt{2}$. Similarly, equating the expression $P(\frac{1}{3}) = 2^{\frac{1}{3}}$ with the calculation $P(\frac{1}{3}) = \sqrt[3]{2}$ gives the reasonable definition $2^{\frac{1}{3}} = \sqrt[3]{2}$.

Solution continued on next page

Explanations and Examples: N.RN.1

- f. The reasoning mistakenly assumes linear growth within each hour, i.e., that the amount of population growth is the same each half hour. We know instead that the *percentage* growth is constant, not the raw change in population. If we were to apply the faulty reasoning to the first hour, we would get the following values:

Hours into study	0	$\frac{1}{2}$	1
Population (thousands)	4	6	8

However, this does not have constant percentage growth: from $t = 0$ to $t = \frac{1}{2}$ this population grew by 50% (ratio = 1.5), but then from $t = \frac{1}{2}$ to $t = 1$ the ratio is only 1.33. If you graphed this data, instead of seeing a smoothly increasing curve, you would see a series of connected line segments of increasing slopes.

- Complete the table below:

Expression	Numerical Value	Expression	Numerical Value
$4^{\frac{1}{2}} = ?$		${}^2\sqrt{4^1} = \sqrt{4} = ?$	
$64^{\frac{1}{3}} = ?$		${}^3\sqrt{64^1} = ?$	
$8^{\frac{2}{3}} = ?$		${}^3\sqrt{8^2} = ?$	
$16^{\frac{1}{4}} = ?$		${}^4\sqrt{16^1} = ?$	
$25^{-\frac{1}{2}} = ?$		$({}^2\sqrt{25})^{-1} = \frac{1}{\sqrt{25}} = ?$	
$(2^3)^{\frac{1}{2}} = ?$		${}^2\sqrt{(2)^3} = ?$	

1. What do you notice about your answers to the problems in the same row?
2. Is there some pattern that relates the two expressions in each row to one another? Describe the pattern.
3. Given the expression $(5^3)^{\frac{1}{4}}$, what expression using a root symbol would yield the same numerical value?
4. Given the expression ${}^3\sqrt{54}$, what expression utilizing a fractional exponent would yield the same numerical value?

Continued on next page

Instructional Strategies: N.RN.1-2

In the traditional pathway, for Algebra I in implementing the standards in curriculum, these standards should occur before discussing exponential functions with continuous domains.

The goal is to show that a fractional exponent can be expressed as a radical or a root. For example, an exponent of $\frac{1}{3}$ is equivalent to a cube root; an exponent of $\frac{1}{4}$ is equivalent to a fourth root.

Review the power rule, $(b^n)^m = b^{nm}$ for whole number exponents i.e., $(7^2)^3 = 7^6$.

Compare examples, such as $(7^{1/2})^2 = 7^1 = 7$ and $(\sqrt{7})^2 = 7$, to help students establish a connection between radicals and rational exponents: $7^{1/2} = \sqrt{7}$ and, in general, $b^{1/2} = \sqrt{b}$.

Provide opportunities for students to explore the equality of the values using calculators, such as $7^{1/2}$ and $\sqrt{7}$.

Offer sufficient examples and exercises to prompt the definition of fractional exponents, and give students practice in converting expressions between radical and exponential forms.

When n is a positive integer, generalize the meaning of $b^{1/n} = \sqrt[n]{b^1}$ and then to $b^{m/n} = \sqrt[n]{b^m}$, where n and m are integers and n is greater than or equal to 2. When m is a negative integer, the result is the reciprocal of the root

$$b^{-m/n} = \frac{1}{\sqrt[n]{b^m}}$$

Stress the two rules of rational exponents: 1) the numerator of the exponent is the base's power and 2) the denominator of the exponent is the order of the root. When evaluating expressions involving rational exponents, it is often helpful to break an exponent into its parts – a power and a root – and then decide if it is easier to perform the root operation or the exponential operation first.

Model the use of precise mathematics vocabulary (e.g., base, exponent, radical, root, cube root, square root etc.). The rules for integer exponents are applicable to rational exponents as well; however, the operations can be slightly more complicated because of the fractions. When multiplying exponents, powers are added ($b^n \cdot b^m = b^{n+m}$).

When dividing exponents, powers are subtracted $\frac{b^n}{b^m} = b^{n-m}$. When raising an exponent to an exponent, powers are multiplied $(b^n)^m = b^{nm}$.

Common Misconceptions: N.RN.1-2

Students sometimes misunderstand the meaning of exponential operations, the way powers and roots relate to one another, and the order in which they should be performed. Attention to the base is very important.

Consider examples: $(-81^{3/4})$ and $(-81)^{3/4}$. The position of a negative sign of a term with a rational exponent can mean that the rational exponent should be either applied first to the base, 81, and then the opposite of the result is taken, $(-81^{3/4})$, or the rational exponent should be applied to a negative term $(-81)^{3/4}$. The answer of $\sqrt[4]{81}$ will be not real if the denominator of the exponent is even. If the root is odd, the answer will be a negative number.

Students should be able to make use of estimation when incorrectly using multiplication instead of exponentiation.

Students may believe that the fractional exponent in the expression $36^{1/3}$ means the same as a factor of $\frac{1}{3}$ in multiplication expression, $36 \cdot \frac{1}{3}$ and multiply the base by the exponent.

Number and Quantity: The Real Number System [\(N-RN\)](#)

Cluster: *Extend the properties of exponents to rational exponents.*

Standard: N.RN.2 Rewrite expressions involving radicals and rational exponents using the properties of exponents.

Suggested Standards for Mathematical Practice (MP):

MP.7 Look for and make use of structure.

Connections: See [N.RN.1](#)

Common Misconceptions: See [N.RN.1](#)

Explanations and Examples: N.RN.2

Convert from radical representation to using rational exponents and vice versa.

Students can explain and apply mathematical concepts and carry out mathematical procedures with precision and fluency.

Examples:

- $\sqrt[3]{5^2} = 5^{\frac{2}{3}}$; $5^{\frac{2}{3}} = \sqrt[3]{5^2}$
- Rewrite using fractional exponents: $\sqrt[5]{16} = \sqrt[5]{2^4} = 2^{\frac{4}{5}}$
- Rewrite $\frac{\sqrt{x}}{x^2}$ in at least three alternate forms. *Solution:* $x^{-\frac{3}{2}} = \frac{1}{x^{\frac{3}{2}}} = \frac{1}{\sqrt{x^3}} = \frac{1}{x\sqrt{x}}$
- Rewrite $\sqrt[4]{2^{-4}}$ using only rational exponents.
- Rewrite $\sqrt[3]{x^3 + 3x^2 + 3x + 1}$ in simplest form.

Continued on next page

Explanations and Examples: N.RN.2

- For items 1a – 1e, determine whether each equation is True or False.

1a. $\sqrt{32} = 2^{\frac{5}{2}}$

True False

1b. $16^{\frac{3}{2}} = 8^2$

True False

1c. $4^{\frac{1}{2}} = \sqrt[4]{64}$

True False

1d. $2^8 = (\sqrt[3]{16})^6$

True False

1e. $(\sqrt{64})^{\frac{1}{3}} = 8^{\frac{1}{6}}$

True False

Solution: 1a. T

1b. T

1c. F

1d. T

1e. F

Instructional Strategies: See [N.RN.1](#)

Number and Quantity: The Real Number System [\(N-RN\)](#)

Cluster: *Use properties of rational and irrational numbers.*

Standard: N.RN.3 Explain why the sum or product of two rational numbers is rational; that the sum of a rational number and an irrational number is irrational; and that the product of a nonzero rational number and an irrational number is irrational.

Suggested Standards for Mathematical Practice (MP):

MP.2 Reason abstractly and quantitatively.

MP.3 Construct viable arguments and critique the reasoning of others.

Connections:

In high school, practicing operations with rational and irrational numbers helps students to understand the properties of real numbers and the relationships between number sets.

Algebraic manipulations and reasoning become a powerful tool for transferring students' experience in proofs from geometry to proofs in algebra.

Explanations and Examples: N.RN.3

Know and justify that when adding or multiplying two rational numbers the result is a rational number.

Know and justify that when adding a rational number and an irrational number the result is irrational.

Know and justify that when multiplying of a nonzero rational number and an irrational number the result is irrational.

Since every difference is a sum and every quotient is a product, this includes differences and quotients as well. Explaining why the four operations on rational numbers produce rational numbers can be a review of students understanding of fractions and negative numbers. Explaining why the sum of a rational and an irrational number is irrational, or why the product is irrational, includes reasoning about the inverse relationship between addition and subtraction (or between multiplication and addition).

Examples:

- Explain why the number 2π must be irrational, given that π is irrational.

Sample Response: If 2π were rational, then half of 2π would also be rational, so π would have to be rational as well.

Continued on next page

Explanations and Examples: N.RN.3

- **Part A**

The rectangle shown below has a length of 6 feet.

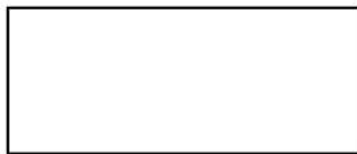

6 feet

The value of the area of the rectangle, in square feet, is an irrational number. Therefore, the number that represents the width of the rectangle must be —

- A. a whole number.
- B. a rational number.
- C. an irrational number.
- D. a non-real complex number.

- **Part B**

The length, ℓ , and width, w , of the rectangle shown below have values that are rational numbers.

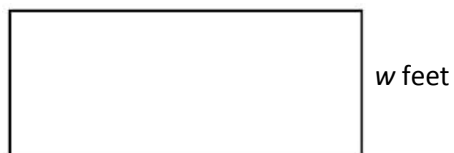

ℓ feet

w feet

Construct an informal proof that shows that the value of the area, in square feet, of the rectangle must be a rational number.

Sample Response:

Part A: C

Continued on next page

Explanations and Examples: N.RN.3

Part B

Given: ℓ is rational; w is rational.

Prove: $\ell \times w$ is rational.

Proof: Since ℓ is rational, by the definition of rational number, ℓ can be written in the form $\frac{a}{b}$, where a and b are both integers and b is non-zero. Similarly, since w is rational, by the definition of rational number, w can be written in the form $\frac{c}{d}$, where c and d are both integers and d is non-zero. Then $\ell \times w = \frac{a}{b} \times \frac{c}{d} = \frac{ac}{bd}$.

Since the set of integers is closed under the operation of multiplication, both ac and bd are integers.

Thus $\ell \times w$ is the ratio of two integers. So by the definition of rational number, $\ell \times w$ is rational.

Instructional Strategies: N.RN.3

This cluster is an excellent opportunity to incorporate algebraic proof, both direct and indirect, in teaching properties of number systems.

Students should explore concrete examples that illustrate that for any two rational numbers written in form $\frac{a}{b}$ and $\frac{c}{d}$, where b and d are natural numbers and a and c are integers, the following are true:

$\frac{a}{b} + \frac{c}{d} = \frac{ad+bc}{bd}$ represents a rational number, and

$\frac{a}{b} \times \frac{c}{d} = \frac{ac}{bd}$ represents a rational number.

Continue exploring situations where the sum of a rational number and an irrational number is irrational (e.g., a sum of rational number 2 and irrational number $\sqrt{3}$ is $(2 + \sqrt{3})$, which is an irrational).

Proofs are valid ways to justify not only geometry statements also algebraic statements.

Use indirect algebraic proof to generalize the statement that the sum of a rational and irrational number is irrational.

Assume that x is an irrational number and the sum of x and a rational number $\frac{a}{b}$ is also rational and is represented as $\frac{c}{d}$.

$$x + \frac{a}{b} = \frac{c}{d}$$

$$x = \frac{c}{d} - \frac{a}{b}$$

$x = \frac{cb-ad}{bd}$ represents a rational number.

Since the last statement contradicts a given fact that x is an irrational number, the assumption is wrong and a sum of a rational number and an irrational number has to be irrational. Similarly, it can be proven that the product of a non-zero rational and an irrational number is irrational.

Continued on next page

Instructional Strategies: N.RN.3

Students need to see that results of the operations performed between numbers from a particular number set does not always belong to the same set. For example, the sum of two irrational numbers $(2 + \sqrt{3})$ and $(2 - \sqrt{3})$ is 4, which is a rational number.

Connect N.RN.3 to physical situations, e.g., finding the perimeter of a square of area 2.

Common Misconceptions: N.RN.3

Some students may believe that both terminating and repeating decimals are rational numbers, without considering nonrepeating and nonterminating decimals as irrational numbers.

Students may also confuse irrational numbers and complex numbers, and therefore mix their properties. In this case, students should encounter examples that support or contradict properties and relationships between number sets (i.e., irrational numbers are real numbers and complex numbers are non-real numbers. The set of real numbers is a subset of the set of complex numbers).

By using false extensions of properties of rational numbers, some students may assume that the sum of any two irrational numbers is also irrational. This statement is not always true (e.g., $(2 + \sqrt{3}) + (2 - \sqrt{3}) = 4$, a rational number), and therefore, cannot be considered as a property.

Number and Quantity: Quantities ★ (N-Q)

Cluster: *Reason quantitatively and use units to solve problems.*

Standard: N.Q.1 Use units as a way to understand problems and to guide the solution of multi-step problems; choose and interpret units consistently in formulas; choose and interpret the scale and the origin in graphs and data displays. (★)

Suggested Standards for Mathematical Practice (MP):

MP.2 Reason abstractly and quantitatively. MP.5 Use appropriate tools strategically.
MP.4 Model with mathematics. MP.6 Attend to precision.

Connections: N.Q.1-3

Measuring commonly used object and choosing proper units for the measurements is part of the mathematics curriculum prior to high school. In high school, students experience a broader variety of units through real-world situations and modeling along with the exploration of the different levels of accuracy and precision of the answers. Working with quantities and the relationships between them provides grounding for work with expressions, equations, and functions.

Explanations and Examples: N.Q.1

Interpret units in the context of the problem. When solving a multi-step problem, use units to evaluate the appropriateness of the solution. Choose the appropriate units for a specific formula and interpret the meaning of the unit in that context. Choose and interpret both the scale and the origin in graphs and data displays.

Include word problems where quantities are given in different units, which must be converted to make sense of the problem. For example, a problem might have an object moving 12 feet per second and another at 5 miles per hour.

To compare speeds, students convert 12 feet per second to miles per hour. $\frac{12 \text{ ft}}{1 \text{ sec}} \cdot \frac{1 \text{ mile}}{5280 \text{ ft}} \cdot \frac{60 \text{ sec}}{1 \text{ min}} \cdot \frac{60 \text{ min}}{1 \text{ hr}} = \frac{43200 \text{ mile}}{5280 \text{ hr}} \approx 8.18$

Graphical representations and data displays include, but are not limited to: line graphs, circle graphs, histograms, multi-line graphs, scatterplots, and multi-bar graphs.

Examples:

- The density of kerosene is approximately $0.82 \frac{\text{g}}{\text{mL}}$.

Drag a rate or quantity from the box to each blank to calculate the mass, in kilograms, of 20 liters of kerosene.

$$\underline{\quad 1 \quad} \times \underline{\quad 2 \quad} \times \underline{\quad 3 \quad} \times \underline{\quad 4 \quad}$$

20 L	820 kg	820 mL	2,000 mL
$\frac{0.82 \text{ g}}{1 \text{ mL}}$	$\frac{2000 \text{ mL}}{20 \text{ L}}$	$\frac{1 \text{ L}}{1,000 \text{ mL}}$	$\frac{1,000 \text{ g}}{1 \text{ kg}}$
$\frac{1 \text{ kg}}{1,000 \text{ g}}$	$\frac{1 \text{ kg}}{1,000 \text{ L}}$	$\frac{1,000 \text{ mL}}{1 \text{ L}}$	$\frac{1,000 \text{ L}}{1 \text{ kg}}$

Continued on next page

Explanations and Examples: N.Q.1

Solution:

The student must choose the following four rates of quantities (order does not matter):

$$20 \text{ L}, \frac{1,000 \text{ mL}}{1 \text{ L}}, \frac{0.82 \text{ g}}{1 \text{ mL}}, \text{ and } \frac{1 \text{ Kg}}{1,000 \text{ g}}.$$

- Hannah makes 6 cups of cake batter. She pours and levels all the batter into a rectangular cake pan with a length of 11 inches, a width of 7 inches, and a depth of 2 inches.

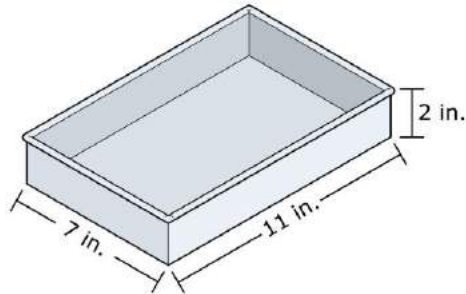

One cubic inch is approximately equal to 0.069 cup.

What is the depth of the batter in the pan when it is completely poured in?

Round your answer to the nearest $\frac{1}{8}$ of an inch.

Solution: $1\frac{1}{8}$ or 1.125 inches

- A fuel oil dealer buys 20,000 gallons of heating oil at \$2.65 per gallon and another 14,000 gallons at \$3.00 per gallon. (The oil is the same grade and quality, but the price varies due to the market.) He has a contract to sell up to 35,000 gallons of oil next month at \$3.25 per gallon, but wants to use as much cash as possible immediately for future investments. To raise cash, he can sell some of his oil to another distributor, who will pay \$2.75 per gallon now. How much investment money can the dealer raise now by selling oil and still be able to break even after selling the remainder next month?

Solution: The dealer has spent: $20,000 \text{ gal.} \times \$2.65/\text{gal.} + 14,000 \text{ gal.} \times \$3.00/\text{gal.} = \$95,000.$

He has 34,000 gallons, and if he sells x gallons now and $(34,000-x)$ gallons next month, he will get

$$\begin{aligned} x \text{ gal.} \cdot \frac{\$2.75}{\text{gal.}} + (34,000-x) \text{ gal.} \cdot \frac{\$3.25}{\text{gal.}} &= 34,000 \cdot \$3.25 - x \cdot \$0.50 \\ &= \$110,500 - \frac{x}{2}. \end{aligned}$$

Thus, the dealer breaks even if $(110,500 - \frac{x}{2}) = 95,000$, or $x = 31,000$.

He can sell 31,000 gallons now, raising a total of \$85,250 for investment, and break even by selling the remaining 3,000 gallons next month.

Continued on next page

Instructional Strategies: N.Q.1-3

In real-world situations, answers are usually represented by numbers associated with units. Units involve measurement and often require a conversion. Measurement involves both precision and accuracy. Estimation and approximation often precede more exact computations.

Students need to develop sound mathematical reasoning skills and forms of argument to make reasonable judgments about their solutions. They should be able to decide whether a problem calls for an estimate, for an approximation, or for an exact answer. To accomplish this goal, teachers should provide students with a broad range of contextual problems that offer opportunities for performing operations with quantities involving units. These problems should be connected to science, engineering, economics, finance, medicine, etc.

Some contextual problems may require an understanding of derived measurements and capability in unit analysis. Keeping track of derived units during computations and making reasonable estimates and rational conclusions about accuracy and the precision of the answers help in the problem-solving process.

For example, while driving in the United Kingdom (UK), a U.S. tourist puts 60 liters of gasoline in his car. The gasoline cost is £1.28 per liter. The exchange rate is £ 0.62978 for each \$1.00. The price for a gallon of a gasoline in the United States is \$3.05. The driver wants to compare the costs for the same amount and the same type of gasoline when he/she pays in UK pounds. Making reasonable estimates should be encouraged prior to solving this problem. Since the current exchange rate has inflated the UK pound at almost twice the U.S. dollar, the driver will pay more for less gasoline.

By dividing \$3.05 by 3.79L (the number of liters in one gallon), students can see that 80.47 cents per liter of gasoline in US is less expensive than £1.28 or \$ 2.03 per liter of the same type of gasoline in the UK when paid in U.S. dollars. The cost of 60 liters of gasoline in UK is $\text{£}30.41$ $\left(\frac{\text{US}\$3.05}{1 \text{ gal}} \times \frac{1 \text{ gal}}{3.79 \text{ L}} \times 60 \text{ L} \times \frac{\text{UK } \text{£}0.62978}{\text{US } \$1.00} = \text{UK } \text{£}30.41\right)$.

In order to compute the cost of the same quantity of gasoline in the United States in UK currency, it is necessary to convert between both monetary systems and units of volume. Based on UK pounds, the cost of 60 liters of gasoline in the U.S. is $\text{£}30.41$ $\left(\frac{\text{US}\$3.05}{1 \text{ gal}} \times \frac{1 \text{ gal}}{3.79 \text{ L}} \times 60 \text{ L} \times \frac{\text{UK } \text{£}0.62978}{\text{US } \$1.00} = \text{UK } \text{£}30.41\right)$.

The computation shows that the gasoline is less expensive in the United States and how an analysis can be helpful in keeping track of unit conversions. Students should be able to correctly identify the degree of precision of the answers which should not be far greater than the actual accuracy of the measurements.

Graphical representations serve as visual models for understanding phenomena that take place in our daily surroundings. The use of different kinds of graphical representations along with their units, labels and titles demonstrate the level of students' understanding and foster the ability to reason, prove, self-check, examine relationships and establish the validity of arguments. Students need to be able to identify misleading graphs by choosing correct units and scales to create a correct representation of a situation or to make a correct conclusion from it.

Common Misconceptions: N.Q.1-3

Students may not realize the importance of the units' conversions in conjunction with the computation when solving problems involving measurements. Students often have difficulty understanding how ratios expressed in different units can be equal to one. For example, $\frac{5280 \text{ ft}}{1 \text{ mile}}$ is simply one, and it is permissible to multiply by that ratio.

Students need to make sure to put the quantities in the numerator or denominator so that the terms can cancel appropriately.

Since today's calculating devices often display 8 to 10 decimal places, students frequently express answers to a much greater degree of precision than the required.

Number and Quantity: Quantities ★ [\(N-Q\)](#)

Cluster: *Reason quantitatively and use units to solve problems.*

Standard: N.Q.2 Define appropriate quantities for the purpose of descriptive modeling. (★)

Suggested Standards for Mathematical Practice (MP):

MP.2 Reason abstractly and quantitatively.
MP.4 Model with mathematics.

MP.6 Attend to precision.

Connections: See [N.Q.1](#)

Common Misconceptions: See [N.Q.1](#)

Explanations and Examples: N.Q.2

Determine and interpret appropriate quantities when using descriptive modeling.

Given a situation or problem, students propose and debate the best quantities used to answer the question in small group discussions.

Examples:

- What type of measurements would one use to determine their income and expenses for one month?
- How could one express the number of car accidents in Kansas?
- Find a good measure of overall highway safety; propose and debate measures such as fatalities per year per driver, fatalities per year, or fatalities per vehicle-mile traveled.
- Give an example of a real-world situation and explain what unit or quantity you expressed the answer in and why.
- How can you determine which scale and unit to use when creating a graph to represent a set of data?

Instructional Strategies: See [N.Q.1](#)

Number and Quantity: Quantities ★ [\(N-Q\)](#)

Cluster: *Reason quantitatively and use units to solve problems.*

Standard: N.Q.3 Choose a level of accuracy appropriate to limitations on measurement when reporting quantities. (★)

Suggested Standards for Mathematical Practice (MP):

MP.2 Reason abstractly and quantitatively.

MP.5 Use appropriate tools strategically.

MP.3 Construct viable arguments and critique the reasoning of others.

MP.6 Attend to precision.

MP.4 Model with mathematics.

Connections: See [N.Q.1](#)

Common Misconceptions: See [N.Q.1](#)

Explanations and Examples: N.Q.3

Determine the accuracy of values based on their limitations in the context of the situation.

The margin of error and tolerance limit varies according to the measure, tool used, and context.

Examples:

- Determining price of gas by estimating to the nearest cent is appropriate because you will not pay in fractions of a cent but the cost of gas is $\frac{\$3.479}{\text{gallon}}$.
- A liquid weed-killer comes in four different bottles, all with the same active ingredient. The accompanying table gives information about the concentration of active ingredient in the bottles, the size of the bottles, and the price of the bottles. Each bottle's contents is made up of active ingredient and water.

	Concentration	Amount in Bottle	Price of Bottle
A	1.04%	64 fl oz.	\$12.99
B	18.00%	32 fl oz.	\$22.99
C	41.00%	32 fl oz.	\$39.99
D	1.04%	24 fl oz.	\$5.99

- a. You need to apply a 1% solution of the weed killer to your lawn. Rank the four bottles in order of best to worst buy. How did you decide what made a bottle a better buy than another?
- b. The size of your lawn requires a total of 14 fl. oz. of active ingredient. Approximately how much would you need to spend if you bought only the A bottles? Only the B bottles? Only the C bottles? Only the D bottles?

Supposing you can only buy one type of bottle, which type should you buy so that the total cost to you is the least for this particular application of weed killer?

The principal purpose of the task is to explore a real-world application problem with algebra, working with units and maintaining reasonable levels of accuracy throughout. Of particular interest is that the optimal solution for long-term purchasing of the active ingredient is achieved by purchasing bottle C, whereas minimizing total cost for a *particular* application comes from purchasing bottle B. Students might need the instructor's aid to see that this is just the observation that buying in bulk may not be a better deal if the extra bulk will go unused.

Continued on next page

Explanations and Examples: N.Q.3*Solution:*

- a. All of the bottles have the same active ingredient, and all can be diluted down to a 1% solution, so all that matters in determining value is the cost per fl. oz. of active ingredient. We estimate this in the following table:

	Amount active in Bottle	Price of bottle	Cost per ounce
A	$1.04\% \times 64 \approx 0.64$ fl oz	$\$12.99 \approx \13	$\frac{13}{0.64} \approx \20 per fl oz
B	$18.00\% \times 32 \approx 6$ fl oz	$\$22.99 \approx \23	$\frac{23}{6} \approx \$4$ per fl oz
C	$41.00\% \times 32 \approx 13$ fl oz	$\$39.99 \approx \40	$\frac{40}{13} \approx \$3$ per fl oz
D	$1.04\% \times 24 \approx 0.24$ fl oz	$\$5.99 \approx \6	$\frac{6}{0.24} \approx \$24$ per fl oz

If we assume that receiving more active ingredient per dollar is a better buy than less active ingredient per dollar, the ranking in order of best-to-worst buy is C,B,A,D.

- b. The A bottles have about 0.64 fl. oz. of active ingredient per bottle so to get 14 fl. oz. we need
 $\frac{14 \text{ fl. oz.}}{0.64 \text{ fl. oz. /bottle}} \approx 22$ bottles.

Purchasing 22 A bottles at about \$13 each will cost about \$286.

The B bottles have a little less than 6 fl. oz. of active ingredient per bottle so to get 14 fl. oz. we need 3 bottles. Purchasing 3 B bottles at about \$23 each will cost about \$69.

The C bottles have a little more than 13 fl. oz. of active ingredient per bottle, so we need 2 bottles. Purchasing 2 C bottles at about \$40 each will cost about \$80.

The D bottles have only 0.24 fl. oz. of active ingredient per bottle, so to get 14 fl. oz. we need
 $\frac{14 \text{ fl. oz.}}{0.24 \text{ fl. oz. /bottle}} \approx 58$ bottles.

Purchasing 58 D bottles at about \$6 each will cost about \$348.

Thus, although the C bottle is the cheapest when measured in dollars/fl. oz., the B bottles are the best deal for this job because there is too much unused when you buy C bottles.

Instructional Strategies: See [N.Q.1](#)

Number and Quantity: The Complex Number System (N-CN)

Cluster: *Perform arithmetic operations with complex numbers.*

Standard: N.CN.1 Know there is a complex number i such that $i^2 = -1$, and every complex number has the form $a + bi$ with a and b real.

Suggested Standards for Mathematical Practice (MP):

MP.2 Reason abstractly and quantitatively.

MP.6 Attend to precision.

Connections: N.CN.1-2

The use of complex numbers is spread throughout mathematics and its applications to science, such as electrical engineering, physics, statistics and aeronautical engineering.

The existence of complex numbers makes every quadratic equation with real coefficients solvable over the complex number system. This paves the way for the Fundamental Theorem of Algebra, which says that an n^{th} degree polynomial has n solutions in the complex numbers.

Explanations and Examples: N.CN.1

Every complex number can be written in the form $a + bi$ where a and b are real numbers. The square root of a negative number is a complex number. Complex numbers can be added, subtracted, and multiplied like binomials. The commutative, associative, and distributive properties hold true when adding, subtracting, and multiplying complex numbers.

Examples:

- | | Problem | Solution | <i>bi Form</i> |
|----|----------------|--|----------------|
| 1. | $\sqrt{-36}$ | $\sqrt{-36} = \sqrt{-1} \cdot \sqrt{36} = 6i$ | $6i$ |
| 2. | $2\sqrt{-49}$ | $2\sqrt{-49} = 2\sqrt{-1} \cdot \sqrt{49} = 2 \cdot 7i = 14i$ | $14i$ |
| 3. | $-3\sqrt{-10}$ | $-3\sqrt{-10} = -3\sqrt{-1} \cdot \sqrt{10} = -3 \cdot i \cdot \sqrt{10} = -3i\sqrt{10}$ | $-3i\sqrt{10}$ |
| 4. | $5\sqrt{-8}$ | $5\sqrt{-8} = 5\sqrt{-1} \cdot \sqrt{8} = 5 \cdot i \cdot 2\sqrt{2} = 10i\sqrt{2}$ | $10i\sqrt{2}$ |

- $\sqrt{-1} = i$

- $\sqrt{-4} = 2i$

- $\sqrt{-7} = \sqrt{7}i$

Continued on next page

Instructional Strategies: N.CN.1-2

Before introducing complex numbers, revisit simpler examples demonstrating how number systems can be seen as “expanding” from other number systems in order to solve more equations. For example, the equation $x + 5 = 3$ has no solution as a whole numbers, but it has a solution $x = -2$ as an integers. Similarly, although $7x = 5$ has no solution in the integers, it has a solution $x = \frac{5}{7}$ in the rational numbers. The linear equation $ax + b = c$, where a , b , and c are rational numbers, always has a solution x in the rational numbers: $x = \frac{(c-b)}{a}$.

When moving to quadratic equations, once again some equations do not have solutions, creating a need for larger number systems. For example, $x^2 - 2 = 0$ has no solution in the rational numbers. But it has solutions $\pm\sqrt{2}$ in the real numbers. (The real number line augments the rational numbers, completing the line with the irrational numbers.)

Point out that solving the equation $x^2 - 2 = 0$ in terms of x is equivalent to finding x -intercepts of a graph of $y = x^2 - 2$, which crosses the x -axis at $(-2, 0)$ and $(\sqrt{2}, 0)$. Thus, the graph illustrates that the solutions are $x = \pm\sqrt{2}$.

Next, use an example of a quadratic equation with real coefficients, such as $x^2 + 1 = 0$, which can be written equivalently as $x^2 = -1$. Because the square of any real number is non-negative, it follows that $x^2 = -1$ has no solution in the real numbers. One can see this graphically by noticing that the graph of $y = x^2 + 1$ does not cross the x -axis.

The “solution” to this “impasse” is to introduce a new number, the imaginary unit i , where $i^2 = -1$, and to consider complex numbers of the form $a + bi$, where a and b are real numbers and i is not a real number. Because i is not a real number, expressions of the form $a + bi$ cannot be simplified.

The existence of i , allows every quadratic equation to have two solutions of the form $a + bi$ – either real when $b = 0$, or complex when $b \neq 0$.

In order to find solutions of quadratic equations or to create quadratic equations from its solutions, introduce students to the condition of equality of complex numbers, with addition, subtraction and multiplication of complex numbers.

Stress the importance of the relationships between different number sets and their properties. The complex number system possesses the same basic properties as the real number system: that addition and multiplication are commutative and associative; the existence of additive identity and multiplicative identity; the existence of an additive inverse for every complex number and the existence of multiplicative inverse or reciprocal for every non-zero complex number; and the distributive property of multiplication over the addition. An awareness of the properties minimizes students’ rote memorization and links the rules for manipulations with the complex number system to the rules for manipulations with binomials with real coefficients of the form $a + bx$.

Common Misconceptions: N.CN.1-2

If irrational numbers are confused with non-real or complex numbers, remind students about the relationships between the sets of numbers.

If an imaginary unit i is misinterpreted as -1 instead of $\sqrt{-1}$, re-establish a definition of i .

Some properties of radicals that are true for real numbers are not true for complex numbers. In particular, for positive real numbers a and b , $\sqrt{a} \cdot \sqrt{b} = \sqrt{(a \cdot b)}$ but $\sqrt{-a} \cdot \sqrt{-b} \neq \sqrt{(-a)(-b)}$ and $\frac{\sqrt{a}}{\sqrt{b}} = \sqrt{\left(\frac{a}{b}\right)}$ and $\frac{\sqrt{a}}{\sqrt{b}} = \sqrt{\left(\frac{a}{b}\right)}$ but $\frac{\sqrt{-a}}{\sqrt{-b}} \neq \sqrt{\frac{(-a)}{(-b)}}$. If those properties are getting misused, provide students with an example, such as

$10 = \sqrt{100} = \sqrt{(-25)(-4)} = \sqrt{-25} \cdot \sqrt{-4} = 5i \cdot 2i = 10i^2 = -10$ that leads to a contradiction that a positive real number is equal to a negative number.

Number and Quantity: The Complex Number System [\(N-CN\)](#)

Cluster: *Perform arithmetic operations with complex numbers.*

Standard: N.CN.2 Use the relation $i^2 = -1$ and the commutative, associative, and distributive properties to add, subtract, and multiply complex numbers.

Suggested Standards for Mathematical Practice (MP):

MP.2 Reason abstractly and quantitatively.

MP.7 Look for and make use of structure.

MP.8 Look for and express regularity in repeated reasoning.

Connections: See [N.CN.1](#)

Common Misconceptions: See [N.CN.1](#)

Explanations and Examples: N.CN.2

Apply the fact that the complex number $i^2 = -1$.

Recognize that $i^4 = i^8 = i^{12} = i^{16} = \dots = i^{4k}$ (where k is a positive integer) = 1, and use the relation $i^2 = -1$ to justify this fact.

Recognize that $i^2 = i^6 = i^{10} = i^{14} = \dots = i^{4k-2}$ (where k is a positive integer) = -1, and use the relation $i^2 = -1$ to justify this fact.

Recognize that $i^3 = i^7 = i^{11} = i^{15} = \dots = i^{4k-1}$ (where k is a positive integer) = $-i$, and use the relation $i^2 = -1$ to justify this fact.

Recognize that $i = i^5 = i^9 = i^{13} = \dots = i^{4k-3}$ (where k is a positive integer) = i , and use the relation $i^2 = -1$ to justify this fact.

Use the associative, commutative, and distributive properties, to add, subtract, and multiply complex numbers.

Examples:

- Simplify the following expression. Justify each step using the commutative, associative and distributive properties.

$$(3 - 2i)(-7 + 4i)$$

Solutions may vary; one solution follows:

$$\begin{aligned} & (3 - 2i)(-7 + 4i) \\ & 3(-7 + 4i) - 2i(-7 + 4i) \quad \text{Distributive Property} \\ & -21 + 12i + 14i - 8i^2 \quad \text{Distributive Property} \\ & -21 + (12i + 14i) - 8i^2 \quad \text{Associative Property} \\ & -21 + i(12 + 14) - 8i^2 \quad \text{Distributive Property} \\ & -21 + 26i - 8i^2 \quad \text{Computation} \\ & -21 + 26i - 8(-1) \quad i^2 = -1 \\ & -21 + 26i + 8 \quad \text{Computation} \\ & -21 + 8 + 26i \quad \text{Commutative Property} \\ & -13 + 26i \quad \text{Computation} \end{aligned}$$

Number and Quantity: The Complex Number System (N-CN)

Cluster: *Use complex numbers in polynomial identities and equations.*

Standard: N.CN.7 Solve quadratic equations with real coefficients that have complex solutions.

Suggested Standards for Mathematical Practice (MP):

MP.1 Make sense of problems and persevere in solving them.

MP.7 Look for and make use of structure.

Connections:

This standard has a direct connection to the standard **A.REI.4** in the Algebra conceptual category. A solid understanding of number systems, including complex numbers, is foundational for advancing in solving various types of equations, investigating functions and sketching their graphs.

Explanations and Examples: N.CN.7

Solve quadratic equations with real coefficients that have solutions of the form $a + bi$ and $a - bi$.

Determine when a quadratic equation in standard form, $ax^2 + bx + c = 0$, has complex roots by looking at a graph of $f(x) = ax^2 + bx + c$ or by calculating the discriminant.

Examples:

- Within which number system can $x^2 = -2$ be solved? Explain how you know.
- Solve $x^2 + 2x + 2 = 0$ over the complex numbers.
- Find all solutions of $2x^2 + 5 = 2x$ and express them in the form $a + bi$.
- Will a quadratic equation with real coefficients always have real solutions? Why or why not?

Instructional Strategies: N.CN.7

Revisit quadratic equations with real coefficients and a negative discriminant and point out that this type of equation has no real number solution. Emphasize that with the extension of the real number system to complex numbers any quadratic equation has a solution. Since the process of solving a quadratic equation may involve the use of the quadratic formula with a negative discriminant, defining a square root of a negative number becomes critical $\sqrt{-N} = i\sqrt{N}$, where N is a positive real number; i is the imaginary unit and $i^2 = -1$). After the square root of a negative number has been defined, emphasize that the quadratic formula can be used without restriction.

While solving quadratic equations using the quadratic formula, students should observe that the quadratic equation always has a pair of solutions regardless of the value of the discriminant.

Common Misconceptions: N.CN.7

In the cases of quadratic equations, when the use of quadratic formula is not critical, students sometime ignore the negative solutions. For example, for the equation $x^2 = 9$, students may mention 3 and forget about (-3) , or mention $3i$ and forget about $(-3i)$ for the equation $x^2 = -9$. If this misconception persists, advise students to solve this type of quadratic equation either by factoring or by the quadratic formula

Conceptual Category Algebra

Expressions. An expression is a record of a computation with numbers, symbols that represent numbers, arithmetic operations, exponentiation, and, at more advanced levels, the operation of evaluating a function. Conventions about the use of parentheses and the order of operations assure that each expression is unambiguous. Creating an expression that describes a computation involving a general quantity requires the ability to express the computation in general terms, abstracting from specific instances.

Reading an expression with comprehension involves analysis of its underlying structure. This may suggest a different but equivalent way of writing the expression that exhibits some different aspect of its meaning. For example, $p + 0.05p$ can be interpreted as the addition of a 5% tax to a price p . Rewriting $p + 0.05p$ as $1.05p$ shows that adding a tax is the same as multiplying the price by a constant factor.

Algebraic manipulations are governed by the properties of operations and exponents, and the conventions of algebraic notation. At times, an expression is the result of applying operations to simpler expressions. For example, $p + 0.05p$ is the sum of the simpler expressions p and $0.05p$. Viewing an expression as the result of operation on simpler expressions can sometimes clarify its underlying structure.

A spreadsheet or a computer algebra system (CAS) can be used to experiment with algebraic expressions, perform complicated algebraic manipulations, and understand how algebraic manipulations behave.

Equations and Inequalities. An equation is a statement of equality between two expressions, often viewed as a question asking for which values of the variables the expressions on either side are in fact equal. These values are the solutions to the equation. An identity, in contrast, is true for all values of the variables; identities are often developed by rewriting an expression in an equivalent form.

The solutions of an equation in one variable form a set of numbers; the solutions of an equation in two variables form a set of ordered pairs of numbers, which can be plotted in the coordinate plane. Two or more equations and/or inequalities form a system. A solution for such a system must satisfy every equation and inequality in the system.

An equation can often be solved by successively deducing from it one or more simpler equations. For example, one can add the same constant to both sides without changing the solutions, but squaring both sides might lead to extraneous solutions. Strategic competence in solving includes looking ahead for productive manipulations and anticipating the nature and number of solutions.

Some equations have no solutions in a given number system, but have a solution in a larger system. For example, the solution of $x + 1 = 0$ is an integer, not a whole number; the solution of $2x + 1 = 0$ is a rational number, not an integer; the solutions of $x^2 - 2 = 0$ are real numbers, not rational numbers; and the solutions of $x^2 + 2 = 0$ are complex numbers, not real numbers.

The same solution techniques used to solve equations can be used to rearrange formulas. For example, the formula for the area of a trapezoid, $A = ((b_1 + b_2)/2)h$, can be solved for h using the same deductive process.

Inequalities can be solved by reasoning about the properties of inequality. Many, but not all, of the properties of equality continue to hold for inequalities and can be useful in solving them.

Connections to Functions and Modeling. Expressions can define functions, and equivalent expressions define the same function. Asking when two functions have the same value for the same input leads to an equation; graphing the two functions allows for finding approximate solutions of the equation. Converting a verbal description to an equation, inequality, or system of these is an essential skill in modeling.

Algebra Standards Overview

Note: The standards identified with a (+) contain additional mathematics that students should learn in order to take advanced courses such as calculus, advanced statistics or discrete mathematics that go beyond the mathematics that all students should study in order to be college- and career-ready. Explanations and examples of these standards are not included in this document.

Modeling Standards: *Specific modeling standards appear throughout the high school standards indicated by a star symbol (★).* [\(RETURN TO PG. 5\)](#)

Seeing Structure in Expressions (A-SSE)

- *Interpret the structure of expressions.*
[A.SSE.1](#) (★) [A.SSE.2](#)
- *Write expressions in equivalent forms to solve problems.*
[A.SSE.3](#) (★) [A.SSE.4](#) (★)

Arithmetic with Polynomials and Rational Expressions (A-APR)

- *Perform arithmetic operations on polynomials.*
[A.APR.1](#)
- *Understand the relationship between zeros and factors of polynomials.*
[A.APR.2](#) [A.APR.3](#)
- *Use polynomial identities to solve problems.*
[A.APR.4](#) [A.APR.5](#) (+)
- *Rewrite rational expressions.*
[A.APR.6](#) [A.APR.7](#) (+)

Creating Equations (★) (A-CED)

- *Create equations that describe numbers or relationships.*
[A.CED.1](#) (★) [A.CED.2](#) (★) [A.CED.3](#) (★) [A.CED.4](#) (★)

Reasoning with Equations and Inequalities (A-REI)

- *Understand solving equations as a process of reasoning and explain the reasoning.*
[A.REI.1](#) [A.REI.2](#)
- *Solve equations and inequalities in one variable.*
[A.REI.3](#) [A.REI.4](#)
- *Solve systems of equations.*
[A.REI.5](#) [A.REI.6](#) [A.REI.7](#) [A.REI.8](#) (+) [A.REI.9](#) (+)
- *Represent and solve equations and inequalities graphically.*
[A.REI.10](#) [A.REI.11](#) (★) [A.REI.12](#)

Algebra: Seeing Structure in Expressions [\(A-SSE\)](#)

Cluster: *Interpret the structure of expressions.*

Standard: A.SSE.1 Interpret expressions that represent a quantity in terms of its context. (★)

- Interpret parts of an expression, such as terms, factors, and coefficients.
- Interpret complicated expressions by viewing one or more of their parts as a single entity. *For example, interpret $P(1+r)^n$ as the product of P and a factor not depending on P .*

Suggested Standards for Mathematical Practice (MP):

MP.1 Make sense of problems and persevere in solving them. MP.4 Model with mathematics.
MP.2 Reason abstractly and quantitatively. MP.7 Look for and make use of structure.

Connections: A.SSE.1-2

An introduction to the use of variable expressions and their meaning, as well as the use of variables and expressions in real-life situations is included in the Expressions and Equations Domain of Grade 7.

Explanations and Examples: A.SSE.1

In Algebra 1, students work with linear, exponential, and quadratic expressions. In Algebra 2, students extend these concepts to general polynomials and rational expressions.

Identify the different parts of the expression and explain their meaning within the context of a problem. Decompose expressions and make sense of the multiple factors and terms by explaining the meaning of the individual parts.

Students should understand the vocabulary for the parts that make up the whole expression and be able to identify those parts and interpret their meaning in terms of a context.

Examples:

- What are the factors of $P(1+r)^n$? Which part(s) of this expression depend on P ?
- (a) A mixture contains A liters of liquid fertilizer in 10 liters of water. Write an expression for the concentration of fertilizer in the mixture, and explain what each part of the expression represents.
- (b) Another mixture contains twice as much fertilizer in the same amount of water as the mixture in part (a). Write an expression for the concentration of the new mixture, and explain why this concentration is not twice as much as the concentration of the first mixture.
- A company uses two different sized trucks to deliver sand. The first truck can transport x cubic yards, and the second y cubic yards. The first truck makes S trips to a job site, while the second makes T trips. What do the following expressions represent in practical terms?

- $S + T$
- $x + y$
- $xS + yT$
- $xS + yT$
 $S+T$

Continued on next page

Explanations and Examples: A.SSE.1

Sample Response:

- S is the number of trips the first truck makes to a job site, and T is the number of trips the second truck makes to a job site. It follows that $S + T =$ the total number of trips both trucks make to a job site.
- We know that x and y are the amount of sand, in cubic yards, that the first and second truck can transport, respectively. Then $x + y =$ the total amount of sand that both trucks can transport together. In other words, the company can transport $x + y$ cubic yards of sand in a single trip using both trucks.
- We can think of $xS + yT$ in separate terms. The first term, xS , multiplies x , the amount of sand the first truck can transport, by S , the number of trips the first truck makes to a job site. This means $xS =$ the total amount of sand being delivered to a job site by the first truck

In the second term, y , the amount of sand the second truck can transport, is being multiplied by T , the number of trips the second truck makes. This means $yT =$ the total amount of sand being delivered to a job site by the second truck.

We then have that $xS + yT =$ the total amount of sand (in cubic yards) being delivered to a job site by both trucks.

- From part (c), we know that $xS + yT$ is the total amount of sand, in cubic yards, being delivered to a job site. We also know from part (a) that $S + T$ is the number of total trips being made to a job site.

By dividing $xS + yT$ by $S + T$, we are averaging out the amount of sand being transported over the total number of trips. So, $\frac{xS + yT}{S + T}$

- Suppose the cost of cell phone service for a month is represented by the expression $0.40s + 12.95$. Students can analyze how the coefficient of 0.40 represents the cost of one minute (40¢), while the constant of 12.95 represents a fixed, monthly fee, and s stands for the number of cell phone minutes used in the month. Similar real-world examples, such as tax rates, can also be used to explore the meaning of expressions.

Instructional Strategies: A.SSE.1-2

Extending beyond simplifying an expression, this cluster addresses interpretation of the components in an algebraic expression. A student should recognize that in the expression $2x + 1$, “2” is the coefficient, “2” and “ x ” are factors, and “1” is a constant, as well as “ $2x$ ” and “1” being *terms* of the binomial expression. Development and proper use of mathematical language is an important building block for future content. Using real-world context examples, the nature of algebraic expressions can be explored.

Have students create their own expressions that meet specific criteria (e.g., number of terms factorable, difference of two squares, etc.) and verbalize how they can be written and rewritten in different forms. Additionally, pair/group students to share their expressions and rewrite one another’s expressions.

Hands-on materials, such as algebra tiles, can be used to establish a visual understanding of algebraic expressions and the meaning of terms, factors and coefficients. Technology may be useful to help a student recognize that two different expressions represent the same relationship. For example, since $(x - y)(x + y)$ can be rewritten as $x^2 - y^2$, they can put both expressions into a graphing calculator (or spreadsheet) and have it generate two tables (or two columns of one table), displaying the same output values for each expression.

Factoring by grouping is another example of how students might analyze the structure of an expression.

To factor $3x(x - 5) + 2(x - 5)$, students should recognize that the “ $x - 5$ ” is common to both expressions being added, so it simplifies to $(3x + 2)(x - 5)$. Students should become comfortable with rewriting expressions in a variety of ways until a structure emerges.

Continued on next page

Common Misconceptions: A.SSE.1-2

Students may believe that the use of algebraic expressions is merely the abstract manipulation of symbols. Use of real-world context examples to demonstrate the meaning of the parts of algebraic expressions is needed to counter this misconception.

Students may also believe that an expression cannot be factored because it does not fit into a form they recognize. They need help with reorganizing the terms until structures become evident.

Students will often combine terms that are not like terms. For example, $2 + 3x = 5x$ or $3x + 2y = 5xy$.

Students sometimes forget the coefficient of 1 when adding like terms. For example, $x + 2x + 3x = 5x$ rather than $6x$.

Students will change the degree of the variable when adding/subtracting like terms. For example, $2x + 3x = 5x^2$ rather than $5x$.

Students will forget to distribute to all terms when multiplying. For example, $6(2x + 1) = 12x + 1$ rather than $12x + 6$.

Students may not follow the Order of Operations when simplifying expressions. For example, $4x^2$ when $x = 3$ may be incorrectly evaluated as $4 \cdot 3^2 = 12^2 = 144$, rather than $4 \cdot 9 = 36$. Another common mistake occurs when the distributive property should be used prior to adding/subtracting. For example, $2 + 3(x - 1)$ incorrectly becomes $5(x - 1) = 5x - 5$ instead of $2 + 3(x - 1) = 2 + 3x - 3 = 3x - 1$.

Students fail to use the property of exponents correctly when using the distributive property. For example, $3x(2x - 1) = 6x - 3x = 3x$ instead of simplifying as $3x(2x - 1) = 6x^2 - 3x$.

Students fail to understand the structure of expressions. For example, they will write $4x$ when $x = 3$ is 43 instead of $4x = 4 \cdot x$ so when $x = 3$, $4x = 4 \cdot 3 = 12$. In addition, students commonly miscalculate $-3^2 = 9$ rather than $-3^2 = -9$. Students routinely see -3^2 as the same as $(-3)^2 = 9$. A method that may clear up the misconception is to have students rewrite as $-x^2 = -1 \cdot x^2$ so they know to apply the exponent before the multiplication of -1 .

Students frequently attempt to “solve” expressions. Many students add “= 0” to an expression they are asked to simplify. Students need to understand the difference between an equation and an expression.

Students commonly confuse the properties of exponents, specifically the product of powers property with the power of a power property. For example, students will often simplify $(x^2)^3 = x^5$ instead of x^6 .

Students will incorrectly translate expressions that contain a difference of terms. For example, 8 less than 5 times a number is often incorrectly translated as $8 - 5n$ rather than $5n - 8$.

Algebra: Seeing Structure in Expressions [\(A-SSE\)](#)

Cluster: *Interpret the structure of expressions.*

Standard: A.SSE.2 Use the structure of an expression to identify ways to rewrite it. *For example, see $x^4 - y^4$ as $(x^2)^2 - (y^2)^2$, thus recognizing it as a difference of squares that can be factored as $(x^2 - y^2)(x^2 + y^2)$.*

Suggested Standards for Mathematical Practice (MP):

MP.2 Reason abstractly and quantitatively.

MP.7 Look for and make use of structure.

Connections: See [A.SSE.1](#)

Common Misconceptions: See [A.SSE.1](#)

Explanations and Examples: A.SSE.2

Linear, quadratic, and exponential expressions are the focus in Algebra I, and integer exponents are extended to rational exponents (only those with square or cubed roots). In Algebra 2, the expectation is to extend to polynomial and rational expressions.

Rewrite algebraic expressions in different equivalent forms such as factoring or combining like terms.

Use factoring techniques such as common factors, grouping, the difference of two squares, the sum or difference of two cubes, or a combination of methods to factor completely. Students should extract the greatest common factor (whether a constant, a variable, or a combination of each). If the remaining expression is quadratic, students should factor the expression further.

Simplify expressions including combining like terms, using the distributive property and other operations with polynomials.

Examples:

- Factor. $x^3 - 2x^2 - 35x$.
- Find a value for a , a value for k , and a value for n , so that $(3x + 2)(2x - 5) = ax^2 + kx + n$.

Solution: Using the distributive property of multiplication over addition, we have, for all real numbers x ,

$$(3x+2)(2x-5) = (3x+2)(2x) + (3x+2)(-5) = 6x^2 + 4x - 15x - 10 = 6x^2 - 11x - 10.$$

So, $a = 6$, $k = -11$, and $n = -10$.

- Write two expressions that are equivalent forms of expression below:

$$m^4 + 5m^2 + 4$$

Solution: $(m^2)^2 + 5(m^2) + 4$; $(m^2 + 4)(m^2 + 1)$

Continued on next page

Explanations and Examples: A.SSE.2

- Suppose P and Q give the sizes of two different animal populations, where $Q > P$. In (a)–(d), say which of the given pair of expressions is larger. Briefly explain your reasoning in terms of the two populations.

a. $P + Q$ and $2P$

b. $\frac{P}{P+Q}$ and $\frac{P+Q}{2}$

c. $(Q - P)/2$ and $Q - P/2$

d. $P + 50t$ and $Q + 50t$

Sample Response:

- a. The expression $P+Q$ is larger.

- The expression $P+Q$ gives the total size of the two populations put together.
- The expression $2P$ gives the size of a population twice as large as P .
- Putting the smaller population together with the larger yields more animals than merely doubling the smaller.

Another way to see this is to notice that $2P = P+P$, which is smaller than $P + Q$ because adding P to P is less than adding Q to P .

- b. The expression $\frac{P+Q}{2}$ is larger.

- The total size of the two populations put together is $P + Q$, so the expression $\frac{P+Q}{2}$ gives the fraction of this total belonging to P . Since $P < P + Q$, this will be a number less than 1. For instance, if $P = 100$ and $Q = 150$, this fraction equals $\frac{100}{100+150} = 0.4 = 40\%$.
- The average or mean size of the two populations is their sum divided by two, or $\frac{P+Q}{2}$. This will be a number between P and Q , so it is larger than P (since P and Q describe animal populations). For instance, if $P = 100$ and $Q = 150$, the average is $\frac{100+150}{2} = 125$.

- c. The expression $Q - \frac{P}{2}$ is larger.

- The expression $\frac{(Q-P)}{2}$ gives half the difference between P and Q . For instance, if $Q = 150$ and $P = 100$, half the difference is $\frac{150-100}{2} = 25$.
- The expression $Q - \frac{P}{2}$ gives the difference between Q and a population half the size of P . For instance, if $Q = 150$ and $P = 100$, this difference equals $150 - \frac{100}{2} = 100$.

To see why the second of these is bigger, write

$$\frac{(Q-P)}{2} = \frac{Q}{2} - \frac{P}{2}$$

In the expression $Q - \frac{P}{2}$, we subtract $\frac{P}{2}$ from Q . But in $\frac{(Q-P)}{2}$, we subtract the same value, $\frac{P}{2}$, from a smaller amount, $\frac{Q}{2}$.

- d. The expression $Q + 50t$ is larger.

- In both expressions, the same value, $50t$, is added to the population.
- Since $P < Q$, adding $50t$ to P results in a smaller value than adding the same amount to Q .

Algebra: Seeing Structure in Expressions [\(A-SSE\)](#)

Cluster: *Write expressions in equivalent forms to solve problems.*

Standard: A.SSE.3 Choose and produce an equivalent form of an expression to reveal and explain properties of the quantity represented by the expression. (★)

- Factor a quadratic expression to reveal the zeros of the function it defines.
- Complete the square in a quadratic expression to reveal the maximum or minimum value of the function it defines.
- Use the properties of exponents to transform expressions for exponential functions. *For example the expression 1.15^t can be rewritten as $(1.15^{1/12})^{12t} \approx 1.012^{12t}$ to reveal the approximate equivalent monthly interest rate if the annual rate is 15%.*

Suggested Standards for Mathematical Practice (MP):

MP.1 Make sense of problems and persevere in solving them. MP.4 Model with mathematics.
MP.2 Reason abstractly and quantitatively. MP.7 Look for and make use of structure.

Connections: A.SSE.3-4

In Grade 8, students compare tables, graphs, expressions and equations of linear relationships. In high school, examination of expressions and equations is intended to include quadratic and exponential, as well as not linear sequences and series. Students will recognize how the form of the expression or equation can provide information about its graph (vertex, minimum, maximum, etc).

Explanations and Examples: A.SSE.3

A.SSE.3a Write expressions in equivalent forms by factoring to find the zeros of a quadratic function and explain the meaning of the zeros.

- Given a quadratic function explain the meaning of the zeros of the function. That is if $f(x) = (x - c)(x - a)$ then $f(a) = 0$ and $f(c) = 0$.
- Given a quadratic expression, explain the meaning of the zeros graphically. That is for an expression; $(x - a)(x - c)$, a and c correspond to the x -intercepts (if a and c are real).
- Express $2(x^3 - 3x^2 + x - 6) - (x - 3)(x + 4)$ in factored form and use your answer to say for what values of x the expression is zero.
- For numbers 1a – 1e, select the two equations with equivalent zeros.

1a. $y = x^2 + 14$

1b. $y = x^2 + 9x + 14$

1c. $y = \left(x - \frac{9}{2}\right)^2 - \frac{25}{4}$

1d. $y = (x + 7)(x + 2)$

1e. $y = \left(\frac{1}{2}x + 7\right)(2x + 2)$

Solutions:

1a. The non-reals zeros are $\pm i\sqrt{14}$

1b. The zeros are -7 and -2

1c. The zeros are 7 and 2 .

1d. the zeros are -7 and -2 .

1e. The zeros are -14 and -1 .

Continued on next page

Explanations and Examples: A.SSE.3

A.SSE.3b Write expressions in equivalent forms by completing the square to convey the vertex form, to find the maximum or minimum value of a quadratic function, and to explain the meaning of the vertex.

- What attributes of a graph will factoring and completing the square reveal about a quadratic function?
- Consider the following algebraic expressions:

$$(n+2)^2 - 4 \text{ and } n^2 + 4n.$$

- a. Use the figures below to illustrate why the following expressions are equivalent

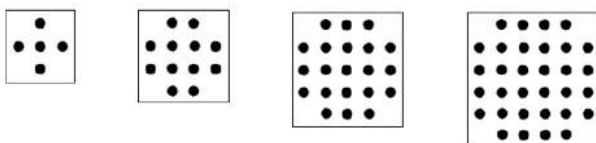

- b. Find some algebraic deductions of the same result.

Solution:

a. A geometric approach to the problem proceeds by identifying, somewhere in the n -th figure, the value n , and seeing two ways of looking at the dots, giving both $(n+2)^2 - 4$ and $n^2 + 4n$. One such approach (among many) is below.

Let n be the number of the figure, with $n = 1$ at the left. We count the dots in each figure in terms of n in two different ways. One represents $n^2 + 4n$ and the other represents $(n+2)^2 - 4$.

Visualizing $n^2 + 4n$:

- n^2 is the inside full square.
- $4n$ is the four outside borders with n in each.

Visualizing $(n+2)^2 - 4$:

- Imagine the larger square with the four additional dots filled in at the corners. Then $(n+2)^2$ is the number of dots in the larger square.
- 4 is the number of dots added.

b. Perhaps most directly, we have $(n+2)^2 - 4 = (n^2 + 4n + 4) - 4 = n^2 + 4n$.

Alternatively, reversing the steps in this series of equalities is precisely the process of completing the square for the expression $n^2 + 4n$. Similarly, the left-hand side could be viewed as a difference of two squares, in which case we can reason:

$$(n+2)^2 - 4 = ((n+2) + 2)((n+2) - 2) = (n+4)(n) = n^2 + 4n.$$

The purpose of above task is to identify the structure in the two algebraic expressions by interpreting them in terms of a geometric context. Students will have likely seen this type of process before, so the principal source of challenge in this task is to encourage a multitude and variety of approaches, both in terms of the geometric argument and in terms of the algebraic manipulation.

Some students might show the equivalence algebraically from the start, either by expanding or by factoring. The algebraic approach should be rewarded, not discouraged. A student who expands could be asked if there is another algebraic method; a student who factors could be asked if there is a way of relating this form to the figure. Observe that the factored form, $(n+4)n$, can be related to the figures as follows: If you take the top and bottom borders, turn them vertically, and place them next to the rest of the figure, you get an $(n+4) \times n$ rectangle of dots.

There is also an opportunity here to discuss the process of justifying an algebraic identity. For one, the algebraic solution in part (b) applies to all real numbers n , whereas the proof by pictures only directly applies to the case that n is a positive integer (though students could be encouraged to replace "numbers of dots" with "areas of regions" to give a version of the geometric proof that works for all positive real numbers

Continued on next page

Explanations and Examples: A.SSE.3

A.SSE.3c Use properties of exponents (such as power of a power, product of powers, power of a product, and rational exponents, etc.) to write an equivalent form of an exponential function to reveal and explain specific information about its approximate rate of growth or decay.

- Write the expression below as a constant times a power of x and use your answer to decide whether the expression gets larger or smaller as x gets larger.

$$\frac{(2x^3)^2(3x^4)}{(x^2)^3}$$

- If x is positive and $x \neq 0$, simplify $\frac{\sqrt{x}}{x^3}$.

Instructional Strategies: A.SSE.3

It is important to balance conceptual understanding and procedural fluency in work with equivalent expressions. For example, development of skill in factoring and completing the square goes hand-in-hand with understanding what different forms of a quadratic expression reveal.

This cluster focuses on linking expressions and functions, i.e., creating connections between multiple representations of functional relations – the dependence between a quadratic expression and a graph of the quadratic function it defines, and the dependence between different symbolic representations of exponential functions. Teachers need to foster the idea that changing the forms of expressions, such as factoring or completing the square, or transforming expressions from one exponential form to another, are not independent algorithms that are learned for the sake of symbol manipulations. They are processes that are guided by goals (e.g., investigating properties of families of functions and solving contextual problems).

Factoring methods that are typically introduced in elementary algebra and the method of completing the square reveals attributes of the graphs of quadratic functions, represented by quadratic equations.

- The solutions of quadratic equations solved by factoring are the x – intercepts of the parabola or zeros of quadratic functions.
- A pair of coordinates (h, k) from the general form $f(x) = a(x - h)^2 + k$ represents the vertex of the parabola, where h represents a horizontal shift and k represents a vertical shift of the parabola $y = x^2$ from its original position at the origin.
- A vertex (h, k) is the minimum point of the graph of the quadratic function if $a > 0$ and is the maximum point of the graph of the quadratic function if $a < 0$. Understanding an algorithm of completing the square provides a solid foundation for deriving a quadratic formula.

Translating among different forms of expressions, equations and graphs helps students to understand some key connections among arithmetic, algebra and geometry. The reverse thinking technique (a process that allows working backwards from the answer to the starting point) can be very effective. Have students derive information about a function's equation, represented in standard, factored or general form, by investigating its graph.

Offer multiple real-world examples of exponential functions. For instance, to illustrate an exponential decay, students need to recognize that in the equation for an automobile cost $C(t) = 20,000(0.75)^t$, the base is 0.75 and between 0 and 1 and the value of \$20,000 represents the initial cost of an automobile that depreciates 25% per year over the course of t years.

Similarly, to illustrate exponential growth, in the equation for the value of an investment over time $A(t) = 10,000(1.03)^t$, where the base is 1.03 and is greater than 1; and the \$10,000 represents the value of an investment when increasing in value by 3% per year for x years.

Continued on next page

Common Misconceptions: A.SSE.3

Some students may believe that factoring and completing the square are isolated techniques within a unit of quadratic equations. Teachers should help students to see the value of these skills in the context of solving higher degree equations and examining different families of functions.

Students may think that the minimum (the vertex) of the graph of $y = (x + 5)^2$ is shifted to the right of the minimum (the vertex) of the graph $y = x^2$ due to the addition sign. Students should explore examples both analytically and graphically to overcome this misconception.

Some students may believe that the minimum of the graph of a quadratic function always occur at the y -intercept.

Algebra: Seeing Structure in Expressions [\(A-SSE\)](#)

Cluster: *Write expressions in equivalent forms to solve problems.*

Standard: A.SSE.4 Derive the formula for the sum of a finite geometric series (when the common ratio is not 1) and use the formula to solve problems. *For example, calculate mortgage payments.* (★)

Suggested Standards for Mathematical Practice (MP):

MP.3 Construct viable arguments and critique the reasoning of others. MP.4 Model with mathematics.
MP.7 Look for and make use of structure. MP.8 Look for and express regularity in repeated reasoning.

Connections: See [A.SSE.3](#)

Explanations and Examples: A.SSE.4

Students understand that a geometric series is the sum of terms in a geometric sequence and can be used to solve real-world problems. The sum of a finite geometric series with common ratio not equal to 1 can be written as a simple formula. Develop the formula for the sum of a finite geometric series when the ratio is not 1.

Use the formula to solve real world problems such as calculating the height of a tree after n years given the initial height of the tree and the rate the tree grows each year. Calculate mortgage payments.

Examples:

- In February, the Bezanson family starts saving for a trip to Australia in September. The Besancon's expect their vacation to cost \$5375. They start with \$525. Each month they plan to deposit 20% more than the previous month. Will they have enough money for their trip?
- A problem such as, "An amount of \$100 was deposited in a savings account on January 1st each of the years 2010, 2011, 2012, and so on to 2019, with annual yield of 7%. What will be the balance in the savings account on January 1, 2020?" illustrates the use of a formula for a geometric series $S_n = \frac{g(1-r^n)}{(1-r)}$ when S_n represents the value of the geometric series with the first term g , constant ration $r \neq 1$, and n terms.

Before using the formula, it might be reasonable to demonstrate the way the formula is derived,

$$\begin{aligned} \text{Multiply by } r \quad S_n &= g + gr + gr^2 + gr^3 + \dots + gr^{n-1} \\ rS_n &= gr + gr^2 + \dots + gr^{n-1} + gr^n \end{aligned}$$

$$\text{Subtract} \quad S - rS = g - gr^n$$

$$\text{Factor} \quad S(1 - r) = g(1 - r^n)$$

$$\text{Divide by } (1 - r) \quad S_n = \frac{g(1-r^n)}{(1-r)}$$

The amount of the investment for January 1, 2020 can be found using: $100(1.07)^{10} + 100(1.07)^9 + \dots + 100(1.07)$. If the first term of this geometric series is $g = 100(1.07)$, the ratio is 1.07 and the number of terms $n = 10$, the formula for the value of geometric series is:

$$S_{10} = \frac{g(1-r^{10})}{(1-r)} = \frac{100(1.07)(1.07^{10} - 1)}{(1.07 - 1)} = \frac{107(1.07^{10} - 1)}{0.07}$$

$$S_{10} \approx \$1478.36$$

Continued on next page

Instructional Strategies: See [A.SSE.3](#)

Common Misconceptions: A.SSE.4

Some students cannot distinguish between arithmetic and geometric sequences, or between sequences and series. To avoid this confusion, students need to experience both types of sequences and series.

Students commonly do not understand what it means to find the sum of a series. For example, if a student is asked to find the sum of the first 17 terms of a series, they will only find the 17th term.

Students often do not recognize that there are multiple ways of finding sums of series. Although it is not always practical, students could use a conceptual method to find the sums rather than using a formula.

Algebra: Arithmetic with Polynomials and Rational Expressions [\(A-APR\)](#)

Cluster: *Perform arithmetic operations on polynomials.*

Standard: A.APR.1 Understand that polynomials form a system analogous to the integers, namely, they are closed under the operations of addition, subtraction, and multiplication; add, subtract, and multiply polynomials.

Suggested Standards for Mathematical Practice (MP):

MP.2 Reason abstractly and quantitatively.

MP.7 Look for and make use of structure.

Connections:

To further explore connections, students might look for commonalities between factoring polynomials and factoring integers. For example, some polynomials are factorable, just as some integers are factorable, and some polynomials are prime or not factorable, just as some integers are prime numbers.

Explanations and Examples: A.APR.1

Focus on polynomial expressions that simplify to forms that are linear or quadratic in a positive integer power of x . Linear and quadratic polynomial expressions are the expectation in Algebra I and beyond quadratic polynomial expressions is the expectation for Algebra 2.

Understand the definition of a polynomial. Understand the concepts of combining like terms and closure. Add, subtract, and multiply polynomials and understand how closure applies under these operations.

Examples:

- Simplify: $\frac{a^2 - b^2}{a + b}$.

- Expand and Simplify: $(x^3 + 3x^2 - 2x + 5)(x - 7)$

- **Part A**

A town council plans to build a public parking lot. The outline below represents the proposed shape of the parking lot.

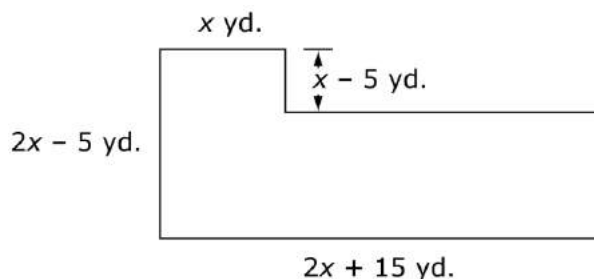

Write an expression for the area, in square feet, of this proposed parking lot. Explain the reasoning you used to find the expression.

Continued on next page

Explanations and Examples: A.APR.1

- **Part B**

The town council has plans to double the area of the parking lot in a few years. They create two plans to do this. The first plan increases the length of the base of the parking lot by p yards, as shown in the diagram below.

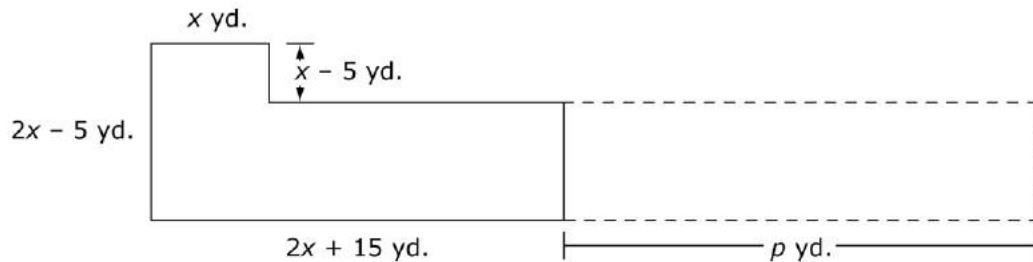

Write an expression in terms of x to represent the value of p , in feet. Explain the reasoning you used to find the value of p .

- **Part C**

The town council's second plan to double the area changes the shape of the parking lot to a rectangle, as shown in the diagram below.

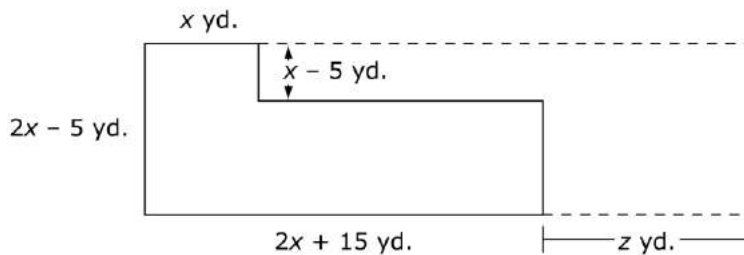

Can the value of z be represented as a polynomial with integer coefficients? Justify your reasoning.

Sample Response:

Part A

$$\begin{aligned} \text{Missing vertical dimension is } & 2x - 5 - (x - 5) = x. \\ \text{Area} &= x(x - 5) + x(2x + 15) \\ &= x^2 - 5x + 2x^2 + 15x \\ &= 3x^2 + 10x \text{ square yards} \end{aligned}$$

Part B

$$\begin{aligned} \text{Doubled area} &= 6x^2 + 20x \text{ square yards.} \\ \text{Area of top left corner} &= x^2 - 5x \text{ square yards.} \\ \text{Area of lower portion with doubled area} &= 6x^2 + 20x - (x^2 - 5x) \\ &= 5x^2 + 25x \text{ square yards} \end{aligned}$$

Since the width remains x yards, the longest length must be $(5x^2 + 25x) \div x = 5x + 25$ yards long.
So, $y = 5x + 25 - (2x + 15) = 5x + 25 - 2x - 15 = 3x + 10$ yards.

Part C

If z is a polynomial with integer coefficients, the length of the rectangle, $2x + 15 + z$, would be a factor of the doubled area. Likewise, $2x - 5$ would be a factor of the doubled area. But $2x - 5$ is not a factor of $6x^2 + 20x$. So $2x + 15 + z$ is not a factor either. Therefore, z cannot be represented as a polynomial with integer coefficients.

Continued on next page

Instructional Strategies: A.APR.1

The primary strategy for this cluster is to make connections between arithmetic of integers and arithmetic of polynomials. In order to understand this standard, students need to work toward both understanding and fluency with polynomial arithmetic. Furthermore, to talk about their work, students will need to use correct vocabulary, such as integer, monomial, polynomial, factor, and term.

In arithmetic of polynomials, a central idea is the distributive property, because it is fundamental not only in polynomial multiplication but also in polynomial addition and subtraction.

With the distributive property, there is little need to emphasize *misleading mnemonics*, such as FOIL, which is relevant only when multiplying two binomials, and the procedural reminder to “collect like terms” as a consequence of the distributive property. For example, when adding the polynomials $3x$ and $2x$, the result can be explained with the distributive property as follows: $3x + 2x = (3 + 2)x = 5x$.

An important connection between the arithmetic of integers and the arithmetic of polynomials can be seen by considering whole numbers in base ten place value to be polynomials in the base $b = 10$. For two-digit whole numbers and linear binomials, this connection can be illustrated with area models and algebra tiles. But the connections between methods of multiplication can be generalized further. For example, compare the product 213×47 with the product $(2b^2 + 1b + 3)(4b + 7)$.

$\begin{array}{r} 2b^2 + 1b + 3 \\ \times \quad \quad 4b + 7 \\ \hline 14b^2 + 7b + 21 \\ 8b^3 + 4b^2 + 12b \\ \hline 8b^3 + 18b^2 + 19b + 21 \end{array}$	$\begin{array}{r} 200 + 10 + 3 \\ \times \quad \quad 40 + 7 \\ \hline 1400 + 70 + 21 \\ 8000 + 400 + 120 \\ \hline 8000 + 1800 + 190 + 21 \end{array}$	$\begin{array}{r} 213 \\ \times \quad 47 \\ \hline 1491 \\ 8520 \\ \hline 10011 \end{array}$
--	--	--

Note how the distributive property is in play in each of these examples: In the left-most computation, each term in the factor $(4b + 7)$ must be multiplied by each term in the other factor, $(2b^2 + 1b + 3)$, just like the value of each digit in 47 must be multiplied by the value of each digit in 213, as in the middle computation, which is similar to “partial products methods” that some students may have used for multiplication in the elementary grades. The common algorithm on the right is merely an abbreviation of the partial products method.

The new idea in this standard is called *closure*: A set is *closed* under an operation if when any two elements are combined with that operation, the result is always another element of the same set. In order to understand that polynomials are closed under addition, subtraction and multiplication, students can compare these ideas with the analogous claims for integers: The sum, difference or product of any two integers is an integer, but the quotient of two integers is not always an integer.

For polynomials, students need to reason that the sum (difference or product) of any two polynomials is indeed a polynomial. At first, restrict attention to polynomials with integer coefficients. Later, students should consider polynomials with rational or real coefficients and reason that such polynomials are closed under these operations.

For contrast, students need to reason that polynomials are not closed under the operation of division:

The quotient of two polynomials is not always a polynomial. For example $(x^2 + x) \div x$ is not a polynomial.

Of course, the quotient of two polynomials is sometimes a polynomial. For example, $(x^2 - 9) \div (x - 3) = x + 3$.

Continued on next page

Common Misconceptions: A.APR.1

Some students will apply the distributive property inappropriately. Emphasize that it is the *distributive property of multiplication over addition*. For example, the distributive property can be used to rewrite $2(x + y)$ as $2x + 2y$, because in this product the second factor is a sum (i.e., involving addition). But in the product $2(xy)$, the second factor, (xy) , is itself a product, not a sum.

Some students will still struggle with the arithmetic of negative numbers. Consider the expression $(-3) \cdot (2 + (-2))$. On the one hand, $(-3) \cdot (2 + (-2)) = (-3) \cdot (0) = 0$. But using the distributive property, $(-3) \cdot (2 + (-2)) = (-3) \cdot (2) + (-3) \cdot (-2)$. Because the first calculation gave 0, the two terms on the right in the second calculation must be opposite in sign. Thus, if we agree that $(-3) \cdot (2) = -6$, then it must follow that $(-3) \cdot (-2) = 6$.

Students often forget to distribute the subtraction to terms other than the first one. For example, students will write $(4x + 3) - (2x + 1) = 4x + 3 - 2x + 1 = 2x + 4$ rather than $4x + 3 - 2x - 1 = 2x + 2$.

Students will change the degree of the variable when adding/subtracting like terms. For example, $2x + 3x = 5x^2$ rather than $5x$.

Students may not distribute the multiplication of polynomials correctly and only multiply like terms. For example, they will write $(x + 3)(x - 2) = x^2 - 6$ rather than $x^2 - 2x + 3x - 6$.

Algebra: Arithmetic with Polynomials and Rational Expressions [\(A-APR\)](#)

Cluster: *Understand the relationship between zeros and factors of polynomials.*

Standard: A.APR.2 Know and apply the Remainder Theorem: For a polynomial $p(x)$ and a number a , the remainder on division by $x - a$ is $p(a)$, so $p(a) = 0$ if and only if $(x - a)$ is a factor of $p(x)$. Know and apply the Remainder Theorem: For a polynomial $p(x)$ and a number a , the remainder on division by $x - a$ is $p(a)$, so $p(a) = 0$ if and only if $(x - a)$ is a factor of $p(x)$.

Suggested Standards for Mathematical Practice (MP):

MP.2 Reason abstractly and quantitatively. MP.8 Look for and express regularity in repeated reasoning.
MP.3 Construct viable arguments and critique the reasoning of others.

Connections: A.APR.2-3; A.SSE.3a; A.APR.1

This cluster is about the relationship between the factors of a polynomial, the zeros of the function defined by the polynomial, and the graph of that function.

Explanations and Examples: A.APR.2

Understand how this standard relates to A.SSE.3a.

Understand that a is a root of a polynomial function if and only if $x - a$ is a factor of the function.

The Remainder theorem says that if a polynomial $p(x)$ is divided by $x - a$ for some number a , then the remainder is the constant $p(a)$. That is, $p(x) = q(x)(x - a) + p(a)$. So if $p(a) = 0$, then $p(x) = q(x)(x - a)$.

Examples:

- Let $p(x) = x^3 - 3x^4 + 8x^2 - 9x + 30$. Evaluate $p(-2)$.
What does your answer tell you about the factors of $p(x)$?

Solution: $p(-2) = 0$, so $x + 2$ is a factor of $p(x)$.

- Consider the polynomial function: $P(x) = x^4 - 3x^3 + ax^2 - 6x + 14$, where a is an unknown real number.
If $(x - 2)$ is a factor of this polynomial, what is the value of a ?

Solution:

By the Remainder Theorem, if $(x - 2)$ is a factor of $P(x)$, then $P(2)$ must equal zero.

Therefore, $P(2) = 16 - 3 \cdot 8 + a \cdot 4 - 6 \cdot 2 + 14 = 0$. Simplifying, we find that $4a - 6 = 0$, and $a = \frac{3}{2}$.

The purpose of this task is to emphasize the use of the Remainder Theorem as a method for determining structure in polynomial in equations, and in this particular instance, as a replacement for division of polynomials

One possible solution path is to use polynomial division to divide $P(x)$ by $(x - 2)$ and determine the remainder in terms of a and then solve for a by setting the remainder equal to zero. However, the division operation becomes unwieldy with the unknown parameter a in play. A more straightforward approach is to use the Remainder Theorem.

Continued on next page

Instructional Strategies: A.APR.2-3

As discussed for the previous cluster (**Perform arithmetic operations on polynomials**), polynomials can often be factored. Even though polynomials (i.e., polynomial expressions) can be explored as mathematical objects without consideration of functions, in school mathematics, polynomials are usually taken to define functions. Some equations may include polynomials on one or both sides. The importance here is in distinction between equations that have solutions, and functions that have zeros. Thus, polynomial functions have zeros. This cluster is about the relationship between the factors of a polynomial, the zeros of the function defined by the polynomial, and the graph of that function. The zeros of a polynomial function are the x -intercepts of the graph of the function.

Through some experience with long division of polynomials by $(x - a)$, students get a sense that the quotient is always a polynomial of a polynomial that is one degree less than the degree of the original polynomial, and that the remainder is always a constant. In other words, $p(x) = q(x)(x - a) + r$. Using this equation, students reason that $p(a) = r$. Thus, if $p(a) = 0$, then the remainder $r = 0$, the polynomial $p(x)$ is divisible by $(x - a)$ and $(x - a)$ is a factor of $p(x)$. Conversely, if $(x - a)$ is a factor of $p(x)$, then $p(a) = 0$.

Whereas, the first standard specifically targets the relationship between factors and zeros of polynomials, the second standard requires more general exploration of polynomial functions: graphically, numerically, verbally and symbolically.

Through experience graphing polynomial functions in factored form, students can interpret the Remainder Theorem in the graph of the polynomial function. Specifically, when $(x - a)$ is a factor of a polynomial $p(x)$, then $p(a) = 0$ and therefore $x = a$ is an x -intercept of the graph $y = p(x)$. Conversely, when students notice an x -intercept near $x = b$ in the graph of a polynomial function $p(x)$, then the function has a zero near $x = b$, and $p(b)$ is near zero. Zeros are located approximately when reasoning from a graph. Therefore, if $p(b)$ is not exactly zero, then $(x - b)$ is not a factor of $p(x)$.

Students can benefit from exploring the rational root theorem, which can be used to find all of the possible rational roots (i.e., zeros) of a polynomial with integer coefficients. When the goal is to identify all roots of a polynomial, including irrational or complex roots, it is useful to graph the polynomial function to determine the most likely candidates for the roots of the polynomial that are the x -intercepts of the graph.

When at least one rational root $x = r$ is identified, the original polynomial can be divided by $x - r$, so that additional roots can be sought in the quotient. Long division will suffice in simple cases. Synthetic division is an abbreviated method that is less prone to error in complicated cases, but Computer Algebra Systems may be helpful in such cases. Graphs are used to understand the end-behavior of n^{th} degree polynomial functions, to locate roots and to infer the existence of complex roots. By using technology to explore the graphs of many polynomial functions, and describing the shape, end behavior and number of zeros, students can begin to make the following informal observations:

- The graphs of polynomial functions are continuous.
- An n^{th} degree polynomial has at most n roots and at most $n - 1$ “changes of direction” (i.e., from increasing to decreasing or vice versa).
- An even-degree polynomial has the same end-behavior in both the positive and negative directions: both heading to positive infinity, or both heading to negative infinity, depending upon the sign of the leading coefficient.
- An odd-degree polynomial has opposite end-behavior in the positive versus the negative directions, depending upon the sign of the leading coefficient.
- An odd-degree polynomial function must have at least one real root.

Algebra: Arithmetic with Polynomials and Rational Expressions [\(A-APR\)](#)

Cluster: *Understand the relationship between zeros and factors of polynomials.*

Standard: A.APR.3 Identify zeros of polynomials when suitable factorizations are available, and use the zeros to construct a rough graph of the function defined by the polynomial.

Suggested Standards for Mathematical Practice (MP):

MP.1 Make sense of problems and persevere in solving them.

MP.2 Reason abstractly and quantitatively.

MP.5 Use appropriate tools strategically.

MP.4 Model with mathematics.

MP.8 Look for and express regularity in repeated reasoning.

Connections: [A.SSE.3a](#); [A.APR.1](#)

This cluster is about the relationship between the factors of a polynomial, the zeros of the function defined by the polynomial, and the graph of that function.

Explanations and Examples: A.APR.3

Identify the multiplicity of the zeroes of a factored polynomial and explain how the multiplicity of the zeroes provides a clue as to how the graph will behave when it approaches and leaves the x-intercept.

Sketch a rough graph using the zeroes of a polynomial and other easily identifiable points such as the y-intercept.

Graphing calculators or programs can be used to generate graphs of polynomial functions.

Example:

- Factor the expression $x^3 + 4x^2 - 59x - 126$ and explain how your answer can be used to solve the equation $x^3 + 4x^2 - 59x - 126 = 0$.

Explain why the solutions to this equation are the same as the x-intercepts of the graph of the function $f(x) = x^3 + 4x^2 - 59x - 126$.

Instructional Strategies: A.APR.3

Graphs are used to understand the end-behavior of n^{th} degree polynomial functions, to locate roots and to infer the existence of complex roots. By using technology to explore the graphs of many polynomial functions, and describing the shape, end behavior and number of zeros, students can begin to make the following informal observations:

- The graphs of polynomial functions are continuous.
- An n^{th} degree polynomial has at most n roots and at most $n - 1$ “changes of direction” (i.e., from increasing to decreasing or vice versa).
- An even-degree polynomial has the same end-behavior in both the positive and negative directions: both heading to positive infinity, or both heading to negative infinity, depending upon the sign of the leading coefficient.
- An odd-degree polynomial has opposite end-behavior in the positive versus the negative directions, depending upon the sign of the leading coefficient.
- An odd-degree polynomial function must have at least one real root.

Algebra: Arithmetic with Polynomials and Rational Expressions [\(A-APR\)](#)

Cluster: *Use polynomial identities to solve problems.*

Standard: A.APR.4 Prove polynomial identities and use them to describe numerical relationships.
For example, the polynomial identity $(x^2+y^2)^2 = (x^2-y^2)^2 + (2xy)^2$ can be used to generate Pythagorean triples.

Suggested Standards for Mathematical Practice (MP):

MP.7 Look for and make use of structure.

MP.8 Look for and express regularity in repeated reasoning.

Connections:

When students “see structure in expressions,” they are more likely to use these identities productively in solving problems.

Explanations and Examples: A.APR.4

Understand that polynomial identities include but are not limited to the product of the sum and difference of two terms, the difference of two squares, the sum and difference of two cubes, the square of a binomial, etc .

Prove polynomial identities by showing steps and providing reasons and describing relationships (e.g. determine $81^2 - 80^2$ by applying differences of squares which leads to $(81 + 80)(81-80) = 161$).

Illustrate how polynomial identities are used to determine numerical relationships such as

$$25^2 = (20 + 5)^2 = 20^2 + 2 \cdot 20 \cdot 5 + 5^2$$

Examples:

- Use the distributive law to explain why $x^2 - y^2 = (x - y)(x + y)$ for any two numbers x and y .
- Derive the identity $(x - y)^2 = x^2 - 2xy + y^2$ from $(x + y)^2 = x^2 + 2xy + y^2$ by replacing y by $-y$.
- Use an identity to explain the pattern

$$2^2 - 1^2 = 3$$

$$3^2 - 2^2 = 5$$

$$4^2 - 3^2 = 7$$

$$5^2 - 4^2 = 9$$

Solution: $(n + 1)^2 - n^2 = 2n + 1$ for any whole number n .

Continued on next page

Instructional Strategies: A.APR.4

In Grade 6, students began using the properties of operations to rewrite expressions in equivalent forms. When two expressions are equivalent, an equation relating the two is called an *identity* because it is true for all values of the variables. This cluster is an opportunity to highlight polynomial identities that are commonly used in solving problems. To learn these identities, students need experience using them to solve problems.

Students should develop familiarity with the following special products:

$$(x + y)^2 = x^2 + 2xy + y^2$$

$$(x - y)^2 = x^2 - 2xy + y^2$$

$$(x + y)(x - y) = x^2 - y^2$$

$$(x + a)(x + b) = x^2 + (a + b)x + ab$$

$$(x + y)^3 = x^3 + 3x^2y + 3xy^2 + y^3$$

$$(x - y)^3 = x^3 - 3x^2y + 3xy^2 - y^3$$

Students should be able to prove any of these identities. Furthermore, they should develop sufficient fluency with the first four of these so that they can recognize expressions of the form on either side of these identities in order to replace that expression with an equivalent expression in the form of the other side of the identity.

- With identities such as these, students can discover and explain facts about the number system. For example, in the multiplication table, the perfect squares appear on the diagonal. Diagonally, next to the perfect squares are “near squares,” which are one less than the perfect square. Why?
- Why is the sum of consecutive odd numbers beginning with 1 always a perfect square?
- Numbers that can be expressed as the sum of the counting numbers from 1 to n are called triangular numbers.
What do you notice about the sum of two consecutive triangular numbers? Explain why it works.
- The sum and difference of cubes are also reasonable for students to prove. The focus of this proof should be on generalizing the difference of cubes formula with an emphasis toward finite geometric series.

Algebra: Arithmetic with Polynomials and Rational Expressions [\(A-APR\)](#)

Cluster: *Rewrite rational expressions.*

Standard: A.APR.6 Rewrite simple rational expressions in different forms; write $a(x)/b(x)$ in the form $q(x) + r(x)/b(x)$, where $a(x)$, $b(x)$, $q(x)$, and $r(x)$ are polynomials with the degree of $r(x)$ less than the degree of $b(x)$, using inspection, long division, or, for the more complicated examples, a computer algebra system.

Suggested Standards for Mathematical Practice (MP):

MP.2 Reason abstractly and quantitatively.

MP.7 Look for and make use of structure.

MP.5 Use appropriate tools strategically.

MP.8 Look for and express regularity in repeated reasoning.

Connections:

A.SSE Seeing Structure in Expressions. The arithmetic of rational expressions is fundamentally about seeing the same structure in rational expressions as the arithmetic of rational numbers (i.e., fractions).

Explanations and Examples: A.APR.6

The limitations on rational functions apply to the rational expressions in A-APR.6.

Define rational expressions.

Determine the best method of simplifying a given rational expression.

Rewrite rational expressions, $\frac{a(x)}{b(x)}$, in the form $q(x) + \frac{r(x)}{b(x)}$ by using factoring, long division, or synthetic division.

The polynomial $q(x)$ is called the quotient and the polynomial $r(x)$ is called the remainder. Expressing a rational expression in this form allows one to see different properties of the graph, such as horizontal asymptotes.

Use a computer algebra system for complicated examples to assist with building a broader conceptual understanding.

Examples:

- Find the quotient and remainder for the rational expression $\frac{x^3 - 3x^2 + x - 6}{x^2 + 2}$ and use them to write the expression in a different form.
- Express $f(x) = \frac{2x+1}{x-1}$ in a form that reveals the horizontal asymptote of its graph.

Solution: $f(x) = \frac{2x+1}{x-1} = \frac{2(x-1)+3}{x-1} = \frac{2(x-1)}{x-1} + \frac{3}{x-1} = 2 + \frac{3}{x-1}$, so the horizontal asymptote is $y = 2$.

Continued on next page

Instructional Strategies: A.APR.6

This cluster is the logical extension of the earlier standards on polynomials and the connection to the integers. Now, the arithmetic of rational functions is governed by the same rules as the arithmetic of fractions, based first on division.

In particular, in order to write $\frac{a(x)}{b(x)}$ in the form $q(x) + \frac{r(x)}{b(x)}$, students need to work through the long division

described for A.APR.2-3. This is merely writing the result of the division as a quotient and a remainder.

For example, we can rewrite $\frac{75}{8}$ in the form $9 + \frac{3}{8}$. Note that the fraction $\frac{75}{8}$ is interpreted as the division $75 \div 8$, so that 75 is the dividend and 8 is the divisor. The result indicates that 9 is the quotient and 3 is the remainder. Note that for division of integers, we expect the remainder to be between 0 and the divisor, which in this case is 8. (If the remainder were greater than or equal to 8, we could subtract another 8, and increase the quotient by 1.)

In order to rewrite simple rational expressions in different forms, students need to understand that the rules governing the arithmetic of rational expressions are the same rules that govern the arithmetic of rational numbers (i.e., fractions). To add fractions, we use a common denominator:

$$\frac{a}{b} + \frac{c}{d} = \frac{ad}{bd} + \frac{bc}{bd} = \frac{ad + bc}{bd}$$

as long as $b, d \neq 0$. Although in simple situations, a, b, c , and d would each be whole numbers, in fact they can be polynomials. So now suppose that $a = 2$, $b = (x - 1)$, $c = x$, and $d = (x + 1)$., then

$$\frac{2}{x - 1} + \frac{x}{x + 1} = \frac{2(x + 1)}{(x - 1)(x + 1)} + \frac{(x - 1)x}{(x - 1)(x + 1)} = \frac{2(x + 1) + (x - 1)x}{(x - 1)(x + 1)}$$

And then the numerator can be simplified further:

$$= \frac{2x + 2 + x^2 - x}{(x - 1)(x + 1)} = \frac{x^2 + x + 2}{(x - 1)(x + 1)}$$

In order to meet A.APR.6, students will need some experiences with the arithmetic of simple rational expressions. For most students, the above example helps illustrating the similarity of the form of the arithmetic used with rational expressions and the form of the arithmetic used with rational numbers.

Common Misconceptions: A.APR.6

Students with only procedural understanding of fractions are likely to “cancel” terms (rather than factors of) in the numerator and denominator of a fraction. Emphasize the structure of the rational expression: that the *whole numerator* is divided by the *whole denominator*. In fact, the word “cancel” likely promotes this misconception. It would be more accurate to talk about dividing the numerator and denominator by a common factor.

Algebra: Creating Equations★ (A-CED)

Cluster: *Create equations that describe numbers or relationships.*

Standard: A.CED.1 Create equations and inequalities in one variable and use them to solve problems. *Include equations arising from linear and quadratic functions, and simple rational and exponential functions.* (★)

Suggested Standards for Mathematical Practice (MP):

MP.1 Make sense of problems and persevere in solving them. MP.4 Model with mathematics.
MP.2 Reason abstractly and quantitatively. MP.5 Use appropriate tools strategically.

Connections: A.CED.1-4

Working with expressions and equations, including formulas, is an integral part of the curriculum in Grades 7 and 8. In high school, students explore in more depth the use of equations and inequalities to model real-world problems, including restricting domains and ranges to fit the problem's context, as well as rewriting formulas for a variable of interest.

Explanations and Examples: A.CED.1

In Algebra 1 limit A.CED.1 and A.CED.2 to linear and exponential equations, and, in the case of exponential equations, limit to situations requiring evaluation of exponential functions at integer inputs. Start with work on linear and exponential equations, then, later in the year, extend to quadratic equations.

In Algebra 2 use all available types of functions to create such equations, including root functions but constrain to simple cases.

Create linear, quadratic, rational and exponential equations and inequalities in one variable and use them in a contextual situation to solve problems.

Equations can represent real-world and mathematical problems. Include equations and inequalities that arise when comparing the values of two different functions, such as one describing linear growth and one describing exponential growth.

Examples:

- Given that the following trapezoid has area 54 cm^2 , set up an equation to find the length of the unknown base, and solve the equation.

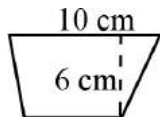

- Lava coming from the eruption of a volcano follows a parabolic path. The height h in feet of a piece of lava t seconds after it is ejected from the volcano is given by $h(t) = -16t^2 + 64t + 936$. After how many seconds does the lava reach its maximum height of 1000 feet?
- The value of an investment over time is given by the equation $A(t) = 10,000(1.03)^t$. What does each part of the equation represent?

Solution: The \$10,000 represents the initial value of the investment. The 1.03 means that the investment will grow exponentially at a rate of 3% per year for t years.

Continued on next page

Explanations and Examples: A.CED.1

- You bought a car at a cost of \$20,000. Each year that you own the car the value of the car will decrease at a rate of 25%. Write an equation that can be used to find the value of the car after t years.

Solution: $C(t) = \$20,000(0.75)^t$. The base is $1 - 0.25 = 0.75$ and is between 0 and 1, representing exponential decay. The value of \$20,000 represents the initial cost of the car.

- Suppose a friend tells you she paid a total of \$16,368 for a car, and you'd like to know the car's list price (the price before taxes) so that you can compare prices at various dealers. Find the list price of the car if your friend bought the car in:
 - Arizona, where the sales tax is 5.6%.
 - New York, where the sales tax is 8.25%.
 - A state where the sales tax is r .

Solution:

- If p is the list price in dollars then the tax on the purchase is $0.056p$. The total amount paid is $p + 0.056p$, so

$$p + 0.056p(1 + 0.056) = 16,368$$

$$(1 + 0.056)p = 16,368$$

$$p = \frac{16,368}{1 + 0.056} = \$15,500.$$

- The total amount paid is $p + 0.0825p$, so

$$p + 0.0825p = 16,368$$

$$(1 + 0.0825)p = 16,368$$

$$p = \frac{16,368}{1 + 0.0825} = \$15,120.55.$$

- The total amount paid is $p + rp$, so

$$p + rp = 16,368$$

$$(1 + r)p = 16,368$$

$$p = \frac{16,368}{1 + r} \text{ dollars.}$$

Instructional Strategies: A.CED.1-4

Provide examples of real-world problems that can be modeled by writing an equation or inequality. Begin with simple equations and inequalities and build up to more complex equations in two or more variables that may involve quadratic, exponential or rational functions.

Discuss the importance of using appropriate labels and scales on the axes when representing functions with graphs.

Examine real-world graphs in terms of constraints that are necessary to balance a mathematical model with the real-world context. For example, a student writing an equation to model the maximum area when the perimeter of a rectangle is 12 inches should recognize that $y = x(6 - x)$ only makes sense when $0 < x < 6$. This restriction on the domain is necessary because the side of a rectangle under these conditions cannot be less than or equal to 0, but must be less than 6. Students can discuss the difference between the parabola that models the problem and the portion of the parabola that applies to the context.

Continued on next page

Instructional Strategies: A.CED.1-4

Explore examples illustrating when it is useful to rewrite a formula by solving for one of the variables in the formula. For example, the formula for the area of a trapezoid ($A = \frac{1}{2} h(b_1 + b_2)$) can be solved for h if the area and lengths of the bases are known but the height needs to be calculated. This strategy of selecting a different representation has many applications in science and business when using formulas.

Provide examples of real-world problems that can be solved by writing an equation, and have students explore the graphs of the equations on a graphing calculator to determine which parts of the graph are relevant to the problem context.

Use a graphing calculator to demonstrate how dramatically the shape of a curve can change when the scale of the graph is altered for one or both variables.

Give students formulas, such as area and volume (or from science or business), and have students solve the equations for each of the different variables in the formula.

Common Misconceptions: A.CED.1-4

Students may believe that equations of linear, quadratic and other functions are abstract and exist only “in a math book,” without seeing the usefulness of these functions as modeling real-world phenomena.

Additionally, they believe that the labels and scales on a graph are not important and can be assumed by a reader, and that it is always necessary to use the entire graph of a function when solving a problem that uses that function as its model.

Students may interchange slope and y -intercept when creating equations. For example, a taxi cab costs \$4 for a dropped flag and charges \$2 per mile. Students may fail to see that \$2 is a rate of change and is slope while the \$4 is the starting cost and incorrectly write the equation as $y = 4x + 2$ instead of $y = 2x + 4$.

Given a graph of a line, students use the x -intercept for b instead of the y -intercept.

Given a graph, students incorrectly compute slope as run over rise rather than rise over run. For example, they will compute slope with the change in x over the change in y .

Students do not know when to include the “or equal to” bar when translating the graph of an inequality.

Students do not correctly identify whether a situation should be represented by a linear, quadratic, or exponential function.

Students often do not understand what the variables represent. For example, if the height h in feet of a piece of lava t seconds after it is ejected from a volcano is given by $h(t) = -16t^2 + 64t + 936$ and the student is asked to find the time it takes for the piece of lava to hit the ground, the student will have difficulties understanding that $h = 0$ at the ground and that they need to solve for t .

Algebra: Creating Equations★ [\(A-CED\)](#)

Cluster: *Create equations that describe numbers or relationships.*

Standard: A.CED.2 Create equations in two or more variables to represent relationships between quantities; graph equations on coordinate axes with labels and scales. (★)

Suggested Standards for Mathematical Practice (MP):

MP.1 Make sense of problems and persevere in solving them. MP.4 Model with mathematics.
MP.2 Reason abstractly and quantitatively. MP.5 Use appropriate tools strategically.

Connections: See [A.CED.1](#)

Common Misconceptions: See [A.CED.1](#)

Explanations and Examples: A.CED.2

Algebra 1: Limit A.CED.1 and A.CED.2 to linear and exponential equations, and, in the case of exponential equations, limit to situations requiring evaluation of exponential functions at integer inputs. Start with work on linear and exponential equations, then, later in the year, extend to quadratic equations.

Algebra 2: While functions used in A.CED.2, 3, and 4 will often be linear, exponential, or quadratic, the types of problems should draw from more complex situations than those addressed in Algebra 1. For example, finding the equation of a line through a given point perpendicular to another line allows one to find the distance from a point to a line. Find the distance from the point $(-2, 5)$ to the line $y = 3x + 1$.

Examples:

- The formula for the surface area of a cylinder is given by $V = \pi r^2 h$, where r represents the radius of the circular cross-section of the cylinder and h represents the height. Choose a fixed value for h and graph V vs. r . Then pick a fixed value for r and graph V vs. h . Compare the graphs.
What is the appropriate domain for r and h ? Be sure to label your graphs and use an appropriate scale.
- Gold is alloyed with different metals to make it hard enough to be used in jewelry. The amount of gold present in a gold alloy is measured in 24ths called karats. 24-karat gold is 100% gold. Similarly, 18-karat gold is 75% gold.
How many ounces of 18-karat gold should be added to an amount of 12-karat gold to make 4 ounces of 14-karat gold? Graph equations on coordinate axes with labels and scales.
- A metal alloy is 25% copper. How much of each alloy should be used to make 1000 grams of a metal alloy that is 45% copper?
- Find a formula for the volume of a single-scoop ice cream cone in terms of the radius and height of the cone. Rewrite your formula to express the height in terms of the radius and volume. Graph the height as a function of radius when the volume is held constant.

Continued on next page

Explanations and Examples: A.CED.2

- David compares the sizes and costs of photo books offered at an online store. The table below shows the cost for each size photo book.

Book Size	Base Price	Cost for Each Additional Page
7-in. by 9-in.	\$20	\$1.00
8-in. by 11-in.	\$25	\$1.00
12-in. by 12-in.	\$45	\$1.50

- Write an equation to represent the relationship between the cost, y , in dollars, and the number of pages, x , for each book size. Be sure to place each equation next to the appropriate book size. Assume that x is at least 20 pages.

Book Size	Equation
7-in. by 9-in.	
8-in. by 11-in.	
12-in. by 12-in.	

- What is the cost of a 12-in. by 12-in. book with 28 pages?
- How many pages are in an 8-in. by 11-in. book that costs \$49?

Solution:

- 7-in. by 9-in. $y = x$
8-in. by 11-in. $y = x + 5$
12-in. by 12-in. $y = 1.50x + 15$
- \$57
- 44 pages

Instructional Strategies: See [A.CED.1](#)

Algebra: Creating Equations★ [\(A-CED\)](#)

Cluster: *Create equations that describe numbers or relationships.*

Standard: A.CED.3 Represent constraints by equations or inequalities, and by systems of equations and/or inequalities, and interpret solutions as viable or non-viable options in a modeling context. *For example, represent inequalities describing nutritional and cost constraints on combinations of different foods.* (★)

Suggested Standards for Mathematical Practice (MP):

MP.1 Make sense of problems and persevere in solving them. MP.4 Model with mathematics.
MP.2 Reason abstractly and quantitatively. MP.5 Use appropriate tools strategically.

Connections: See [A.CED.1](#)

Common Misconceptions: See [A.CED.1](#)

Explanations and Examples: A.CED.3

Algebra 1: Limit A-CED.3 to linear and inequalities. Algebra 2: While functions used in A-CED.2, 3, and 4 will often be linear, exponential, or quadratic, the types of problems should draw from more complex situations than those addressed in Algebra 1.

Write and use a system of equations and/or inequalities to solve a real world problem.

Recognize that the equations and inequalities represent the constraints of the problem.

Examples:

- A club is selling hats and jackets as a fundraiser. Their budget is \$1500 and they want to order at least 250 items. They must buy at least as many hats as they buy jackets. Each hat costs \$5 and each jacket costs \$8.
 - Write a system of inequalities to represent the situation.
 - Graph the inequalities.
 - If the club buys 150 hats and 100 jackets, will the conditions be satisfied?
 - What is the maximum number of jackets they can buy and still meet the conditions?
- Represent inequalities describing nutritional and cost constraints o combinations of different foods.
- The coffee variety *Arabica* yields about 750 kg of coffee beans per hectare, while *Robusta* yields about 1200 kg per hectare. Suppose that a plantation has a hectares of *Arabica* and r hectares of *Robusta*.
 - a) Write an equation relating a and r if the plantation yields 1,000,000 kg of coffee.
 - b) On August 14, 2003, the world market price of coffee was \$1.42 per kg of *Arabica* and \$0.73 per kg of *Robusta*. Write an equation relating a and r if the plantation produces coffee worth \$1,000,000.

This task is designed to make students think about the meaning of the quantities presented in the context and choose which ones are appropriate for the two different constraints presented. The purpose of the task is to have students *generate* the constraint equations for each part (though the problem and not to have students *solve* said equations. If desired, instructors could also use this task to touch on such solutions by finding and interpreting solutions to the system of equations created in parts (a) and (b).

Continued on next page

Explanations and Examples: A.CED.3

Solution:

- a) We see that a hectares of *Arabica* will yield $750a$ kg of beans, and that r hectares of *Robusta* will yield $1200r$ kg of beans. So the constraint equation is

$$750a + 1200r = 1,000,000.$$

- b) We know that a hectares of *Arabica* yield $750a$ kg of beans worth \$1.42/kg for a total dollar value of $1.42(750a) = 1065a$. Likewise, r hectares of *Robusta* yield $1200r$ kg of beans worth \$0.73/kg for a total dollar value of $0.73(1200r) = 876r$. So the equation governing the possible values of a and r coming from the total market value of the coffee is

$$1065a + 876r = 1,000,000.$$

Instructional Strategies: See [A.CED.1](#)

Algebra: Creating Equations★ (A-CED)

Cluster: *Create equations that describe numbers or relationships.*

Standard: A.CED.4 Rearrange formulas to highlight a quantity of interest, using the same reasoning as in solving equations. *For example, rearrange Ohm’s law $V = IR$ to highlight resistance R .* (★)

Suggested Standards for Mathematical Practice (MP):

- MP.1 Make sense of problems and persevere in solving them.
- MP.2 Reason abstractly and quantitatively.
- MP.4 Model with mathematics.
- MP.5 Use appropriate tools strategically.
- MP.7 Look for and make use of structure.

Connections: See [A.CED.1](#)

Common Misconceptions: See [A.CED.1](#)

Explanations and Examples: A.CED.4

Solve multi-variable formulas or literal equations, for a specific variable.

Examples:

- The Pythagorean Theorem expresses the relation between the legs a and b of a right triangle and its hypotenuse c with the equation $a^2 + b^2 = c^2$.
 - Why might the theorem need to be solved for c ?
 - Solve the equation for c and write a problem situation where this form of the equation might be useful.

- Solve $V = \frac{4}{3}\pi r^3$ for radius r .

- Motion can be described by the formula below, where t = time elapsed, u = initial velocity, a = acceleration, and s = distance traveled.

$$s = ut + \frac{1}{2}at^2$$

- Why might the equation need to be rewritten in terms of a ?
- Rewrite the equation in terms of a .

- The figure below is made up of a square with height, h units, and a right triangle with height, h units, and base length, b units.

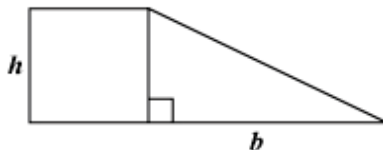

The area of this figure is 80 square units.

Write an equation that solves for the height, h , in terms of b .

Show all work necessary to justify your answer.

Continued on next page

Explanations and Examples: A.CED.4

Sample Response:

$$h^2 + \frac{1}{2}bh = 80$$

$$h^2 + \frac{1}{2}bh + \frac{1}{16}b^2 = 80 + \frac{1}{16}b^2$$

$$\left(h + \frac{1}{4}b\right)^2 = 80 + \frac{1}{16}b^2$$

$$h + \frac{1}{4}b = \sqrt{80 + \frac{1}{16}b^2}$$

$$h = \sqrt{80 + \frac{1}{16}b^2} - \frac{1}{4}b$$

Instructional Strategies: See [A.CED.1](#)

Algebra: Reasoning with Equations and Inequalities [\(A-REI\)](#)

Cluster: *Understand solving equations as a process of reasoning and explain the reasoning.*

Standard: A.REI.1 Explain each step in solving a simple equation as following from the equality of numbers asserted at the previous step, starting from the assumption that the original equation has a solution. Construct a viable argument to justify a solution method.

Suggested Standards for Mathematical Practice (MP):

MP.1 Make sense of problems and persevere in solving them. MP.7 Look for and make use of structure.

MP.2 Reason abstractly and quantitatively.

MP.3 Construct viable arguments and critique the reasoning of others.

Connections: A.REI.1-2

Solving linear equations in one variable and analyzing pairs of simultaneous linear equations are part of the Grade 8 curriculum. In high school, students extend these ideas into radical and rational equations, including justification of steps taken to solve equations and recognition of extraneous solutions when they occur.

Explanations and Examples: A.REI.1

In Algebra 1 students should focus on and master A.REI.1 for linear equations and be able to extend and apply their reasoning to other types of equations in future courses. In Algebra 2, extend to simple rational and radical equations.

Assuming an equation has a solution, construct a convincing argument that justifies each step in the solution process. Justifications may include the associative, commutative, and division properties, combining like terms, multiplication by 1, etc.

Properties of operations can be used to change expressions on either side of the equation to equivalent expressions. In addition, adding the same term to both sides of an equation or multiplying both sides by a non-zero constant produces an equation with the same solutions. Other operations, such as squaring both sides, may produce equations that have extraneous solutions.

Examples:

- Explain why the equation $\frac{x}{2} + \frac{7}{3} = 5$ has the same solutions as the equation $3x + 14 = 30$. Does this mean that $\frac{x}{2} + \frac{7}{3}$ is equal to $3x + 14$?
- Show that $x = 2$ and $x = -3$ are solutions to the equation $x^2 + x = 6$. Write the equation in a form that shows these are the only solutions, explaining each step in your reasoning.
- Transform $2x - 5 = 7$ to $2x = 12$ and tell what property of equality was used.

Solution:

$$\begin{aligned}2x - 5 &= 7 \\2x - 5 + 5 &= 7 + 5 && \text{Addition property of equality.} \\2x &= 12\end{aligned}$$

Continued on next page

Instructional Strategies: A.REI.1-2

Challenge students to justify each step of solving an equation. Transforming $2x - 5 = 7$ to $2x = 12$ is possible because $5 = 5$, so adding the same quantity to both sides of an equation makes the resulting equation true as well. Each step of solving an equation can be defended, much like providing evidence for steps of a geometric proof.

Provide examples for how the same equation might be solved in a variety of ways as long as equivalent quantities are added or subtracted to both sides of the equation, the order of steps taken will not matter.

$$\begin{array}{r}
 3n + 2 = n - 10 \\
 - \quad 2 = -2 \\
 \hline
 3n = n - 12 \quad \text{OR} \quad 3n + 2 = n - 10 \\
 + \quad 10 = +10 \\
 \hline
 3n + 12 = n \quad \text{OR} \quad 3n + 2 = n - 10 \\
 -n = -n \\
 \hline
 2n = -12 \quad \text{OR} \quad 3n + 12 = n \\
 -3n = -3n \\
 \hline
 2n = -12 \quad \text{OR} \quad 12 = -2n \\
 -2 = -2 \\
 \hline
 n = -6 \quad \text{OR} \quad 2n = -12 \\
 n = -6
 \end{array}$$

Connect the idea of adding two equations together as a means of justifying steps of solving a simple equation to the process of solving a system of equations. A system consisting of two linear functions such as $2x + 3y = 8$ and $x - 3y = 1$ can be solved by adding the equations together, and can be justified by exactly the same reason that solving the equation $2x - 4 = 5$ can begin by adding the equation $4 = 4$.

Investigate the solutions to equations such as $3 = x + \sqrt{2x - 3}$. By graphing the two functions, $y = 3$ and $y = x + \sqrt{2x - 3}$, students can visualize that graphs of the functions only intersect at one point. However, subtracting $x = x$ from the original equation yields $3 - x = \sqrt{2x - 3}$ which when both sides are squared produces a quadratic equation that has two roots $x = 2$ and $x = 6$. Students should recognize that there is only one solution ($x = 2$) and that $x = 6$ is generated when a quadratic equation results from squaring both sides; $x = 6$ is extraneous to the original equation. Some rational equations, such as $\frac{x}{(x-2)} = \frac{2}{(x-2)} + \frac{5}{x}$, result in extraneous solutions as well.

Begin with simple, one-step equations and require students to write out a justification for each step used to solve the equation.

Ensure that students are proficient with solving simple rational and radical equations that have no extraneous solutions before moving on to equations that result in quadratics and possible solutions that need to be eliminated.

Provide visual examples of radical and rational equations with technology so that students can see the solution as the intersection of two functions and further understand how extraneous solutions do not fit the model.

It is very important that students are able to reason how and why extraneous solutions arise.

Computer software that generates graphs for visually examining solutions to equations, particularly rational and radical. Examples of radical equations that do and do not result in the generation of extraneous solutions should be prepared for exploration.

Common Misconceptions: A.REI.1-2

Students may believe that solving an equation such as $3x + 1 = 7$ involves “only removing the 1,” failing to realize that the equation $1 = 1$ is being subtracted to produce the next step.

Additionally, students may believe that all solutions to radical and rational equations are viable, without recognizing that there are times when extraneous solutions are generated and have to be eliminated.

Algebra: Reasoning with Equations and Inequalities [\(A-REI\)](#)

Cluster: *Understand solving equations as a process of reasoning and explain the reasoning.*

Standard: A.REI.2 Solve simple rational and radical equations in one variable, and give examples showing how extraneous solutions may arise.

Suggested Standards for Mathematical Practice (MP):

- MP.1 Make sense of problems and persevere in solving them. MP.7 Look for and make use of structure.
MP.2 Reason abstractly and quantitatively.
MP.3 Construct viable arguments and critique the reasoning of others.

Connections: See [A.REI.1](#)

Common Misconceptions: See [A.REI.1](#)

Explanations and Examples: A.REI.2

Give an example of a simple rational or radical equation that has an extraneous solution and explain why it is an extraneous solution.

Examples:

- Solve for x :
 - $\sqrt{x + 2} = 5$
 - $\frac{7}{8}\sqrt{2x - 5} = 21$
 - $\frac{x+2}{x+3} = 2$
 - $\sqrt{3x - 7} = -4$

- a. Solve the following two equations by isolating the radical on one side and squaring both sides:
 - i. $\sqrt{2x + 1} - 5 = -2$

 - ii. $\sqrt{2x + 1} + 5 = 2$

Be sure to check your solutions

Continued on next page

Explanations and Examples: A.REI.2

- b. If we raise both sides of an equation a power, we sometimes obtain an equation which has more solutions than the original one. (Sometimes the extra solutions are called extraneous solutions.)

Which of the following equations result in extraneous solutions when you raise both sides to the indicated power? Explain.

i. $\sqrt{x} = 5$, square both sides

ii. $\sqrt{x} = -5$, square both sides

iii. $\sqrt[3]{x} = 5$, cube both sides

iv. $\sqrt[3]{x} = -5$, cube both sides

- c. Create a square root equation similar to the one in part (a) that has an extraneous solution.

Show the algebraic steps you would follow to look for a solution, and indicate where the extraneous solution arises.

Solutions:

a. i.
$$\begin{aligned}\sqrt{2x+1} - 5 &= -2 \\ (\sqrt{2x+1})^2 &= (3)^2 \\ 2x+1 &= 9 \\ 2x &= 8 \\ x &= 4\end{aligned}$$
 Checking:
$$\begin{aligned}\sqrt{2 \cdot 4 + 1} - 5 &= -2 \\ \sqrt{9} - 5 &= -2 \\ 3 - 5 &= -2 \\ -2 &= -2\end{aligned}$$
 So, $x = 4$ is the solution to the equation.

ii.
$$\begin{aligned}\sqrt{2x+1} + 5 &= 2 \\ (\sqrt{2x+1})^2 &= (-3)^2 \\ 2x+1 &= 9 \\ 2x &= 8 \\ x &= 4\end{aligned}$$
 Checking:
$$\begin{aligned}\sqrt{2 \cdot 4 + 1} + 5 &= 2 \\ \sqrt{9} + 5 &= 2 \\ 3 + 5 &= 2 \\ 8 &\neq 2\end{aligned}$$
 So this equation has no solution.

- b. The only one of the equations that produces an extraneous solution is $\sqrt{x} = -5$

The square root symbol (like all even roots) is defined to be the positive square root, so a positive root can never be equal to a negative number. Squaring both sides of the equation will make that discrepancy disappear; the square of a positive number is positive but so is the square of a negative number, so we'll end up with a solution to the new equation even though there was no solution to the original equation.

This isn't the case with odd roots - a cube root of a positive number is positive, and a cube root of a negative number is negative. When we cube both sides of the last equation, the negative remains, and we end up with a true solution to the equation.

Continued on next page

Explanations and Examples: A.REI.2

- c. If we start with a square root set equal to a negative number, we know that squaring both sides will get us into trouble. Something like $\sqrt{2x+1} = -5$ will work.

If we can add a positive number to both sides, it will be less obvious. Perhaps: $\sqrt{2x+1} + 7 = 2$.

Solving this equation:

$$\begin{aligned}\sqrt{2x+1} + 7 &= 2 \\ (\sqrt{2x+1})^2 &= (-5)^2 * \\ 2x + 1 &= 25 \\ 2x &= 24 \\ x &= 12\end{aligned}$$

* - This is where the extraneous solution comes in. The square root can't be negative, but by squaring both sides, we're losing that information.

Instructional Strategies: See [A.REI.1](#)

Algebra: Reasoning with Equations and Inequalities [\(A-REI\)](#)

Cluster: *Solve equations and inequalities in one variable.*

Standard: A.REI.3 Solve linear equations and inequalities in one variable, including equations with coefficients represented by letters.

Suggested Standards for Mathematical Practice (MP):

MP.2 Reason abstractly and quantitatively.

MP.7 Look for and make use of structure.

MP.8 Look for and express regularity in repeated reasoning.

Connections: A.REI.3-4

In Grades 6-8, students learned how to approach linear equations in which justification of procedures was the basis for proofs. In high school, based on experience gained in solving quadratic equations, students will understand the need for a variety of methods when solving other types of equations, including conics (i.e., ellipses, parabolas, hyperbolas).

Explanations and Examples: A.REI.3

Extend earlier work with solving linear equations to solving linear inequalities in one variable and to solving literal equations that are linear in the variable being solved for. Include simple exponential equations that rely only on application of the laws of exponents, such as $5^x = 125$ or $2^x = \frac{1}{16}$.

Examples:

Solve for the variable:

- $\frac{7}{3}y - 8 = 111$
- $3x > 9$
- $ax + 7 = 12$
- $\frac{3+x}{7} = \frac{x-9}{4}$
- Solve for x : $\frac{2}{3}x + 9 < 18$

Continued on next page

Explanations and Examples: A.REI.3

- Match each inequality in items 1 – 3 with the number line in items A – F that represent the solution to the inequality.

1. $-4x < -12$

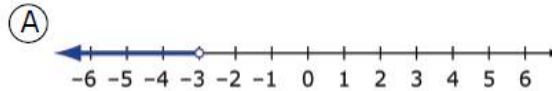

2. $2(x + 2) < 8$



3. $5 - 2x < 2 - x$

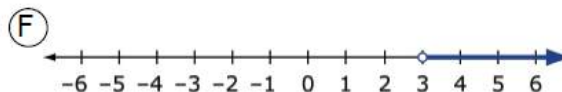

Solutions: 1. F / 2. B / 3. F

Instructional Strategies: A.REI.3-4

There are two major reasons for discussing the topic of inequalities along with equations: First, there are analogies between solving equations and inequalities that help students understand them both. Second, the applications that lead to equations almost always lead in the same way to inequalities.

In grades 6-8, students solve and graph linear equations and inequalities. Graphing experience with inequalities is limited to graphing on a number line diagram. Despite this work, some students will still need more practice to be proficient. It may be beneficial to remind students of the most common solving techniques, such as converting fractions from one form to another, removing parentheses in the sentences, or multiplying both sides of an equation or inequality by the common denominator of the fractions. Students must be aware of what it means to check an inequality's solution. The substitution of the end points of the solution set in the original inequality should give equality regardless of the presence or the absence of an equal sign in the original sentence. The substitution of any value from the rest of the solution set should give a correct inequality.

Continued on next page

Instructional Strategies: A.REI.3

Careful selection of examples and exercises is needed to provide students with meaningful review and to introduce other important concepts, such as the use of properties and applications of solving linear equations and inequalities. Stress the idea that the application of properties is also appropriate when working with equations or inequalities that include more than one variable, fractions and decimals. Regardless of the type of numbers or variables in the equation or inequality, students have to examine the validity of each step in the solution process.

Solving equations for the specified letter with coefficients represented by letters (e.g., $A = \frac{1}{2} h(B + b)$ when solving for b) is similar to solving an equation with one variable. Provide students with an opportunity to abstract from particular numbers and apply the same kind of manipulations to formulas as they did to equations. One of the purposes of doing abstraction is to learn how to evaluate the formulas in easier ways and use the techniques across mathematics and science.

Draw students' attention to equations containing variables with subscripts. The same variables with different subscripts (e.g., x_1 and x_2) should be viewed as different variables that cannot be combined as like terms.

A variable with a variable subscript, such as a_n , must be treated as a single variable – the n^{th} term, where variables a and n have different meaning.

Common Misconceptions: A.REI.3

Some students may believe that for equations containing fractions only on one side, it requires “clearing fractions” (the use of multiplication) only on that side of the equation. To address this misconception, start by demonstrating the solution methods for equations similar to $\frac{1}{4}x + \frac{1}{5}x + \frac{1}{6}x + 46 = x$ and stress that the Multiplication Property of Equality is applied to both sides, which are multiplied by 60.

Students may confuse the rule of changing a sign of an inequality when multiplying or dividing by a negative number with changing the sign of an inequality when one or two sides of the inequality become negative (for ex., $3x > -15$ or $x < -5$).

Some students may believe that subscripts can be combined as $b_1 + b_2 = b_3$ and the sum of different variables d and D is $2D$ ($d + D = 2D$).

Algebra: Reasoning with Equations and Inequalities [\(A-REI\)](#)

Cluster: *Solve equations and inequalities in one variable.*

Standard: A.REI.4 Solve quadratic equations in one variable.

- a. Use the method of completing the square to transform any quadratic equation in x into an equation of the form $(x - p)^2 = q$ that has the same solutions. Derive the quadratic formula from this form.
- b. Solve quadratic equations by inspection (e.g., for $x^2 = 49$), taking square roots, completing the square, the quadratic formula and factoring, as appropriate to the initial form of the equation. Recognize when the quadratic formula gives complex solutions and write them as $a \pm bi$ for real numbers a and b .

Suggested Standards for Mathematical Practice (MP):

MP.2 Reason abstractly and quantitatively.

MP.7 Look for and make use of structure.

MP.8 Look for and express regularity in repeated reasoning.

Connections: See [A.REI.3](#)

Explanations and Examples: A.REI.4

In Algebra 1, student should be able to recognize when the solution to a quadratic equation yields a complex solution; however writing the solution in the complex form $a \pm bi$ for real numbers a and b will be addressed in Algebra 2.

Transform a quadratic equation written in standard form to an equation in vertex form $(x - p)^2 = q$ by completing the square.

Derive the quadratic formula by completing the square on the standard form of a quadratic equation.

Solve quadratic equations in one variable by simple inspection, taking the square root, factoring, and completing the square.

Understand why taking the square root of both sides of an equation yields two solutions.

Use the quadratic formula to solve any quadratic equation, recognizing the formula produces all complex solutions. Write the solutions in the form $a \pm bi$, where a and b are real numbers.

Explain how complex solutions affect the graph of a quadratic equation.

Students should solve by factoring, completing the square, and using the quadratic formula. The zero product property is used to explain why the factors are set equal to zero. Students should relate the value of the discriminant to the type of root to expect. A natural extension would be to relate the type of solutions to $ax^2 + bx + c = 0$ to the behavior of the graph of $y = ax^2 + bx + c$.

Value of Discriminant	Nature of Roots	Nature of Graph
$b^2 - 4ac = 0$	1 real roots	intersects x-axis once
$b^2 - 4ac > 0$	2 real roots	intersects x-axis twice
$b^2 - 4ac < 0$	2 complex roots	does not intersect x-axis

Continued on next page

Explanations and Examples: A.REI.4

Examples:

- Are the roots of $2x^2 + 5 = 2x$ real or complex? How many roots does it have? Find all solutions of the equation.
- What is the nature of the roots of $x^2 + 6x + 10 = 0$? Solve the equation using the quadratic formula and completing the square. How are the two methods related?
- Projectile motion problems, in which the initial conditions establish one of the solutions as extraneous within the context of the problem.
 - An object is launched at 14.7 meters per second (m/s) from a 49-meter tall platform. The equation for the object's height s at time t seconds after launch is $s(t) = -4.9t^2 + 14.7t + 49$, where s is in meters. When does the object strike the ground?

Solution:

$$0 = -4.9t^2 + 14.7t + 49$$

$$0 = t^2 - 3t - 10$$

$$0 = (t + 2)(t - 5)$$

So the solutions for t are $t = 5$ or $t = -2$, but $t = -2$ does not make sense in the context of this problem and therefore is an extraneous solution.

Instructional Strategies: A.REI.4

Completing the square is usually introduced for several reasons to find the vertex of a parabola whose equation has been expanded; to look at the parabola through the lenses of translations of a “parent” parabola $y = x^2$; and to derive a quadratic formula. Completing the square is a very useful tool that will be used repeatedly by students in many areas of mathematics. Teachers should carefully balance traditional paper-pencil skills of manipulating quadratic expressions and solving quadratic equations along with an analysis of the relationship between parameters of quadratic equations and properties of their graphs.

Start by inspecting equations such as $x^2 = 9$ that has two solutions, 3 and -3. Next, progress to equations such as $(x - 7)^2 = 9$ by substituting $x - 7$ for x and solving them either by “inspection” or by taking the square root on each side:

$$\begin{array}{l} x - 7 = 3 \text{ and } x - 7 = -3 \\ x = 10 \qquad \qquad x = 4 \end{array}$$

Graph both pairs of solutions (-3 and 3, 4 and 10) on the number line and notice that 4 and 10 are 7 units to the right of -3 and 3. So, the substitution of $x - 7$ for x moved the solutions 7 units to the right. Next, graph the function $y = (x - 7)^2 - 9$, pointing out that the x -intercepts are 4 and 10, and emphasizing that the graph is the translation of 7 units to the right and 9 units down from the position of the graph of the parent function $y = x^2$ that passes through the origin (0, 0). Generate more equations of the form $y = a(x - h)^2 + k$ and compare their graphs using a graphing technology.

Continued on next page

Instructional Strategies: A.REI.4

Highlight and compare different approaches to solving the same problem. Use technology to recognize that two different expressions or equations may represent the same relationship. For example, since $x^2 - 10x + 25 = 0$ can be rewritten as $(x - 5)(x - 5) = 0$ or $(x - 5)^2 = 0$ or $x^2 = 25$, these are all representations of the same equation that has a double solution $x = 5$. Support it by putting all expressions into graphing calculator. Compare their graphs and generate their tables displaying the same output values for each expression.

Guide students in transforming a quadratic equation in standard form, $0 = ax^2 + bx + c$, to the vertex form $0 = a(x - h)^2 + k$ by separating your examples into groups with $a = 1$ and $a \neq 1$ and have students guess the number that needs to be added to the binomials of the type $x^2 + 6x$, $x^2 - 2x$, $x^2 + 9x$, $x^2 - \frac{2}{3}x$ to form complete square of the binomial $(x - m)^2$.

Then generalize the process by showing the expression $(b/2)^2$ that has to be added to the binomial $x^2 + bx$. Completing the square for an expression whose x^2 coefficient is not 1 can be complicated for some students. Present multiple examples of the type $0 = 2x^2 - 5x - 9$ to emphasize the logic behind every step, keeping in mind that the same process will be used to complete the square in the proof of the quadratic formula.

Discourage students from giving a preference to a particular method of solving quadratic equations. Students need experience in analyzing a given problem to choose an appropriate solution method before their computations become burdensome. Point out that the Quadratic Formula, $x = \frac{-b \pm \sqrt{b^2 - 4ac}}{2a}$, is a universal tool that can solve any quadratic equation; however, it is not reasonable to use the Quadratic Formula when the quadratic equation is missing either a middle term, bx , or a constant term, c . When it is missing a constant term, (e.g., $3x^2 - 10x = 0$) a factoring method becomes more efficient. If a middle term is missing (e.g., $2x^2 - 15 = 0$), a square root method is the most appropriate. Introduce the concept of discriminants and their relationship to the number and nature of the roots of quadratic equation.

Offer students examples of a quadratic equation, such as $x^2 + 9 = 0$. Since the graph of the quadratic function $y = x^2 + 9$ is situated above the x -axis and opens up, the graph does not have x -intercepts and therefore, the quadratic equation does not have real solutions. At this stage introduce students to non-real solutions, such as $x = \pm\sqrt{-9}$ or $x = \pm 3\sqrt{-1}$ and a new number type-imaginary unit i that equals $\sqrt{-1}$. Using i in place of $\sqrt{-1}$; a way to present the two solutions of a quadratic equation in the complex numbers form $a \pm bi$, if a and b are real numbers and $b \neq 0$. Have students observe that if a quadratic equation has complex solutions, the solutions always appear in conjugate pairs, in the form $a + bi$ and $a - bi$. Particularly, for the equation $x^2 = -9$, a conjugate pair of solutions are $0 + 3i$ and $0 - 3i$.

Common Misconceptions: A.REI.4

Some students may think that rewriting equations into various forms (taking square roots, completing the square, using quadratic formula and factoring) are isolated techniques within a unit of quadratic equations. Teachers should help students see the value of these skills in the context of solving higher degree equations and examining different families of functions.

Algebra: Reasoning with Equations and Inequalities [\(A-REI\)](#)

Cluster: *Solve systems of equations.*

Standard: A.REI.5 Prove that, given a system of two equations in two variables, replacing one equation by the sum of that equation and a multiple of the other produces a system with the same solutions.

Suggested Standards for Mathematical Practice (MP):

MP.2 Reason abstractly and quantitatively.

MP.3 Construct viable arguments and critique the reasoning of others.

Connections: A.REI.5-7

Students use their experience in solving and analyzing systems of two linear equations as a foundation for solving and analyzing linear systems with more than two linear equations and systems with non-linear equations.

Explanations and Examples: A.REI.5

The focus of this standard is to provide mathematics justification for the addition (elimination) and substitution methods of solving systems of equations that transform a given system of two equations into a simpler equivalent system that has the same solutions as the original.

Build on student experiences in graphing and solving systems of linear equations from middle school to focus on justification of the methods used. Include cases where the two equations describe the same line (yielding infinitely many solutions) and cases where two equations describe parallel lines (yielding no solution); connect to GPE.5 when it is taught in Geometry, which requires students to prove the slope criteria for parallel lines.

Systems of linear equations can also have one solution, infinitely many solutions or no solutions. Students will discover these cases as they graph systems of linear equations and solve them algebraically.

A system of linear equations whose graphs meet at one point (intersecting lines) has only one solution, the ordered pair representing the point of intersection. A system of linear equations whose graphs do not meet (parallel lines) has no solutions and the slopes of these lines are the same. A system of linear equations whose graphs are coincident (the same line) has infinitely many solutions, the set of ordered pairs representing all the points on the line.

By making connections between algebraic and graphical solutions and the context of the system of linear equations, students are able to make sense of their solutions. Students need opportunities to work with equations and context that include whole number and/or decimals/fractions.

Examples:

- Find x and y using elimination and then using substitution.

$$3x + 4y = 7$$

$$-2x + 8y = 10$$

- Given that the sum of two numbers is 10 and their difference is 4, what are the numbers?
Explain how your answer can be deduced from the fact that they two numbers, x and y , satisfy the equations $x + y = 10$ and $x - y = 4$.

Continued on next page

Instructional Strategies: A.REI.5-7

The Addition and Multiplication Properties of Equality allow finding solutions to certain systems of equations. In general, any linear combination, $m(Ax + By) + n(Cx + Dy) = mE + nF$, of two linear equations

$$Ax + By = E \text{ and}$$

$$Cx + Dy = F$$

intersecting in a single point contains that point. The multipliers m and n can be chosen so that the resulting combination has only an x -term or only a y -term in it. That is, the combination will be a horizontal or vertical line containing the point of intersection.

In the proof of a system of two equations in two variables, where one equation is replaced by the sum of that equation and a multiple of the other equation, produces a system that has the same solutions, let point (x_1, y_1) be a solution of both equations:

$$Ax_1 + By_1 = E \text{ (true)}$$

$$Cx_1 + Dy_1 = F \text{ (true)}$$

Replace the equation $Ax + By = E$ with $Ax + By + k(Cx + Dy)$ on its left side and with $E + kF$ on its right side. The new equation is $Ax + By + k(Cx + Dy) = E + kF$.

Show that the ordered pair of numbers (x_1, y_1) is a solution of this equation by replacing (x_1, y_1) in the left side of this equation and verifying that the right side really equals $E + kF$:

$$Ax_1 + By_1 + k(Cx_1 + Dy_1) = E + kF \text{ (true)}$$

Systems of equations are classified into two groups, consistent or inconsistent, depending on whether or not solutions exist. The solution set of a system of equations is the intersection of the solution sets for the individual equations. Stress the benefit of making the appropriate selection of a method for solving systems (graphing vs. addition vs. substitution). This depends on the type of equations and combination of coefficients for corresponding variables, without giving a preference to either method.

The graphing method can be the first step in solving systems of equations. A set of points representing solutions of each equation is found by graphing these equations. Even though the graphing method is limited in finding exact solutions and often yields approximate values, the use of it helps to discover whether solutions exist and, if so, how many are there?

Prior to solving systems of equations graphically, students should revisit “families of functions” to review techniques for graphing different classes of functions. Alert students to the fact that if one equation in the system can be obtained by multiplying both sides of another equation by a nonzero constant, the system is called consistent, the equations in the system are called dependent and the system has an infinite number of solutions that produces coinciding graphs. Provide students opportunities to practice linear vs. non-linear systems; consistent vs. inconsistent systems; pure computational vs. real-world contextual problems (e.g., chemistry and physics applications encountered in science classes). A rich variety of examples can lead to discussions of the relationships between coefficients and consistency that can be extended to graphing.

The next step is to turn to algebraic methods, elimination or substitution, to allow students to find exact solutions. For any method, stress the importance of having a well-organized format for writing solutions.

Common Misconceptions: A.REI.5-7

Most mistakes that students make are careless rather than conceptual. Teachers should encourage students to learn a certain format for solving systems of equations and check the answers by substituting into all equations in the system. Some students believe that matrices are independent of other areas of mathematics.

Algebra: Reasoning with Equations and Inequalities [\(A-REI\)](#)

Cluster: *Solve systems of equations.*

Standard: A.REI.6 Solve systems of linear equations exactly and approximately (e.g., with graphs), focusing on pairs of linear equations in two variables.

Suggested Standards for Mathematical Practice (MP):

- MP.2 Reason abstractly and quantitatively. MP.6 Attend to precision.
MP.4 Model with mathematics. MP.7 Look for and make use of structure.
MP.5 Use appropriate tools strategically. MP.8 Look for and express regularity in repeated reasoning.

Connections: See [A.REI.5](#)

Common Misconceptions: See [A.REI.5](#)

Explanations and Examples: A.REI.6

The system solution methods can include but are not limited to graphical, elimination/linear combination, substitution, and modeling. Systems can be written algebraically or can be represented in context. Students may use graphing calculators, programs, or applets to model and find approximate solutions for systems of equations.

Examples:

- José had 4 times as many trading cards as Phillipe. After José gave away 50 cards to his little brother and Phillipe gave 5 cards to his friend for this birthday, they each had an equal amount of cards. Write a system to describe the situation and solve the system.

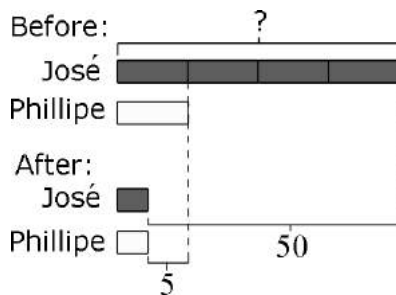

- Solve the system of equations: $x + y = 11$ and $3x - y = 5$. Use a second method to check your answer.
- The opera theater contains 1,200 seats, with three different prices. The seats cost \$45 dollars per seat, \$50 per seat, and \$60 per seat. The opera needs to gross \$63,750 on seat sales. There are twice as many \$60 seats as \$45 seats. How many seats in each level need to be sold?

Continued on next page

Explanations and Examples: A.REI.6

- A restaurant serves a vegetarian and a chicken lunch special each day. Each vegetarian special is the same price. Each chicken special is the same price. However, the price of the vegetarian special is different from the price of the chicken special.
 - On Thursday, the restaurant collected \$467 selling 21 vegetarian specials and 40 chicken specials.
 - On Friday, the restaurant collected \$484 selling 28 vegetarian specials and 36 chicken specials.

What is the cost of each lunch special?

Solution: vegetarian: \$7 and chicken: \$8

Instructional Strategies: See [A.REI.5](#)

Algebra: Reasoning with Equations and Inequalities [\(A-REI\)](#)

Cluster: *Solve systems of equations.*

Standard: A.REI.7 Solve a simple system consisting of a linear equation and a quadratic equation in two variables algebraically and graphically. *For example, find the points of intersection between the line $y = -3x$ and the circle $x^2 + y^2 = 3$.*

Suggested Standards for Mathematical Practice (MP):

- MP.2 Reason abstractly and quantitatively. MP.6 Attend to precision.
MP.4 Model with mathematics. MP.7 Look for and make use of structure.
MP.5 Use appropriate tools strategically. MP.8 Look for and express regularity in repeated reasoning.

Connections: See [A.REI.5](#)

Common Misconceptions: See [A.REI.5](#)

Explanations and Examples: A.REI.7

Include systems consisting of one linear and one quadratic equation. Include systems that lead to work with fractions. For example, finding the intersections between $x^2 + y^2 = 1$ and $y = \frac{(x+1)}{2}$ leads to the point $(\frac{3}{5}, \frac{4}{5})$ on the unit circle, corresponding to the Pythagorean triple $3^2 + 4^2 = 5^2$.

Examples:

- Two friends are driving to the Grand Canyon in separate cars. Suzette has been there before and knows the way but Andrea does not. During the trip Andrea gets ahead of Suzette and pulls over to wait for her. Suzette is traveling at a constant rate of 65 miles per hour. Andrea sees Suzette drive past. To catch up, Andrea accelerates at a constant rate. The distance in miles (d) that her car travels as a function of time in hours (t) since Suzette's car passed is given by $d = 3500t^2$.

Write and solve a system of equations to determine how long it takes for Andrea to catch up with Suzette.

- Sketch the circle with equation $x^2 + y^2 = 1$ and the line with equation $y = 2x - 1$ on the same pair of axes.
 - There is one solution to the pair of equations

$$\begin{aligned}x^2 + y^2 &= 1 \\ y &= 2x - 1\end{aligned}$$

That is clearly identifiable from the sketch. What is it? Verify that it is a solution.

- Find all the solutions to this pair of equations

Continued on next page

Explanations and Examples: A.REI.7

Solution:

The equations $x^2 + y^2 = 1$ and $y = 2x - 1$ are graphed.

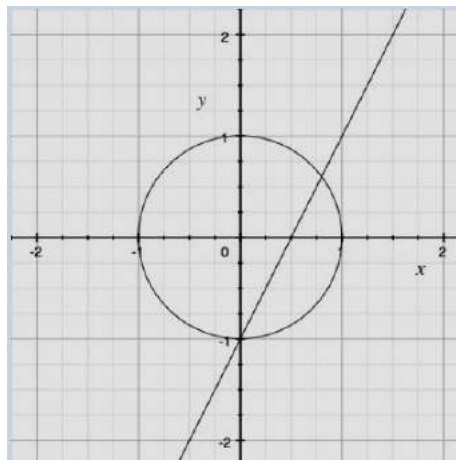

The solution that is clearly identifiable from the graph, the point at which the circle and line intersect, is $(0, 1)$. We can check that $(0, 1)$ is a solution to the pair of equations by substituting 0 for x and -1 for y in both equations.

$$\begin{array}{rcl} x^2 + y^2 = 1 & & y = 2x - 1 \\ (0)^2 + (-1)^2 = 1 & & -1 = 2(0) - 1 \\ 0 + 1 = 1 & & -1 = 0 - 1 \\ 1 = 1 & & -1 = -1 \end{array}$$

We have verified that $(0, 1)$ is a solution to the pair of equations.

From the graph, we can see that there is another solution (in Quadrant 1). However it is difficult to visually determine its exact x - and y - coordinates. To find its exact location we can solve the system of equations by substitution.

Let (x, y) be the intersection point. Since $y = 2x - 1$ by virtue of the point being on the line, we can substitute the quantity $(2x - 1)$ for every y appearing in the equation of the circle. We then simplify as follows;

$$\begin{aligned} x^2 + (2x - 1)^2 &= 1 \\ x^2 + (2x - 1)(2x - 1) &= 1 \\ x^2 + 4x^2 - 2x - 2x + 1 &= 1 \\ 5x^2 - 4x + 1 &= 1 \\ 5x^2 - 4x &= 0 \\ x(5x - 4) &= 0 \\ x = 0 &\quad \text{or} \quad 5x - 4 = 0 \\ & & 5x = 4 \\ & & x = \frac{4}{5} \end{aligned}$$

If $x = 0$, we know $y = -1$, so we have re-discovered the first intersection point we observed. So our second intersection point has x -coordinates equal to $\frac{4}{5}$, and we are left only having to now find its y -coordinate. We simply substitute $\frac{4}{5}$ in either equation and solve for y .

Now we have that $(\frac{4}{5}, \frac{3}{5})$ is also a solution.

$$y = 2x - 1 \quad y = 2\left(\frac{4}{5}\right) - 1 \quad y = \frac{8}{5} - 1 \quad y = \frac{8}{5} - \frac{5}{5} \quad y = \frac{3}{5}$$

Algebra: Reasoning with Equations and Inequalities (A-REI)

Cluster: *Represent and solve equations and inequalities graphically.*

Standard: A.REI.10 Understand that the graph of an equation in two variables is the set of all its solutions plotted in the coordinate plane, often forming a curve (which could be a line).

Suggested Standards for Mathematical Practice (MP):

MP.2 Reason abstractly and quantitatively.

MP.5 Use appropriate tools strategically.

MP.4 Model with mathematics.

MP.6 Attend to precision.

Connections: A.REI.10-12

Solving linear equations in one variable and analyzing pairs of simultaneous linear equations is part of the Grade 8 curriculum. These ideas are extended in high school, as students explore paper-and-pencil and graphical ways to solve equations, as well as how to graph two variable inequalities and solve systems of inequalities.

Explanations and Examples: A.REI.10

In Algebra 1 for A.REI.10 focus on linear and exponential equations and be able to adapt and apply that learning to other types of equations in future courses.

Students can explain and verify that every point (x, y) on the graph of an equation represents values x and y that make the equation true.

Examples:

- Which of the following points is on the circle with equation $(x - 1)^2 + (y + 2)^2 = 5$?
(a) $(1, -2)$ (b) $(2, 2)$ (c) $(3, -1)$ (d) $(3, 4)$
- Graph the equation and determine which of the following points are on the graph of $y = 3^x + 1$.
(a) $(2, 7)$ (b) $(-1, \frac{4}{3})$ (c) $(2, 10)$ (d) $(0, 1)$
- Which graph could represent the solution set of $y = \sqrt{x - 4}$? *Solution: B*

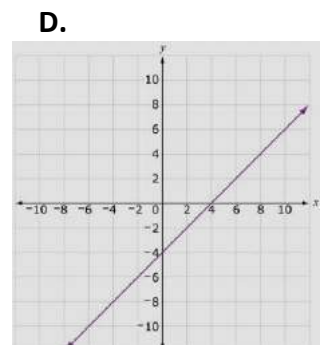
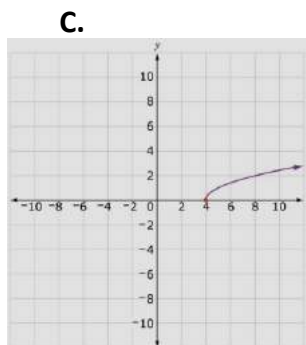
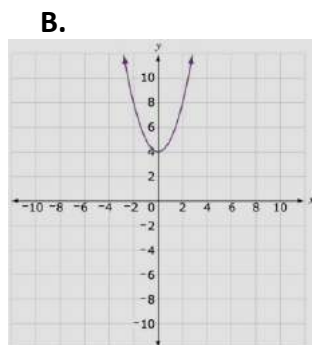
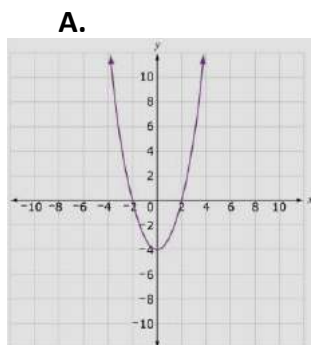

Continued on next page

Instructional Strategies: A.REI.10-12

Beginning with simple, real-world examples, help students to recognize a graph as a set of solutions to an equation. For example, if the equation $y = 6x + 5$ represents the amount of money paid to a babysitter (i.e., \$5 for gas to drive to the job and \$6/hour to do the work), then every point on the line represents an amount of money paid, given the amount of time worked.

Explore visual ways to solve an equation such as $2x + 3 = x - 7$ by graphing the functions $y = 2x + 3$ and $y = x - 7$. Students should recognize that the intersection point of the lines is at $(-10, -17)$. They should be able to verbalize that the intersection point means that when $x = -10$ is substituted into both sides of the equation, each side simplifies to a value of -17 . Therefore, -10 is the solution to the equation. This same approach can be used whether the functions in the original equation are linear, nonlinear or both.

Using technology, have students graph a function and use the trace function to move the cursor along the curve. Discuss the meaning of the ordered pairs that appear at the bottom of the calculator, emphasizing that every point on the curve represents a solution to the equation.

Begin with simple linear equations and how to solve them using the graphs and tables on a graphing calculator. Then, advance students to nonlinear situations so they can see that even complex equations that might involve quadratics, absolute value, or rational functions can be solved fairly easily using this same strategy. While a standard graphing calculator does not simply solve an equation for the user, it can be used as a tool to approximate solutions.

Use the table function on a graphing calculator to solve equations. For example, to solve the equation $x^2 = x + 12$, students can examine the equations $y = x^2$ and $y = x + 12$ and determine that they intersect when $x = 4$ and when $x = -3$ by examining the table to find where the y -values are the same.

Investigate real-world examples of two-dimensional inequalities. For example, students might explore what the graph would look like for money earned when a person earns *at least* \$6 per hour. (The graph for a person earning *exactly* \$6/hour would be a linear function, while the graph for a person earning at least \$6/hour would be a half-plane including the line and all points above it.)

Common Misconceptions: A.REI.10-12

Students may believe that the graph of a function is simply a line or curve “connecting the dots,” without recognizing that the graph represents all solutions to the equation.

Students may also believe that graphing linear and other functions is an isolated skill, not realizing that multiple graphs can be drawn to solve equations involving those functions.

Additionally, students may believe that two-variable inequalities have no application in the real world. Teachers can consider business related problems (e.g., linear programming applications) to engage students in discussions of how the inequalities are derived and how the feasible set includes all the points that satisfy the conditions stated in the inequalities.

Algebra: Reasoning with Equations and Inequalities [\(A-REI\)](#)

Cluster: *Represent and solve equations and inequalities graphically.*

Standard: A.REI.11 Explain why the x -coordinates of the points where the graphs of the equations $y = f(x)$ and $y = g(x)$ intersect are the solutions of the equation $f(x) = g(x)$; find the solutions approximately, e.g., using technology to graph the functions, make tables of values, or find successive approximations. Include cases where $f(x)$ and/or $g(x)$ are linear, polynomial, rational, absolute value, exponential, and logarithmic functions. (★)

Suggested Standards for Mathematical Practice (MP):

MP.2 Reason abstractly and quantitatively.

MP.4 Model with mathematics.

MP.5 Use appropriate tools strategically.

MP.6 Attend to precision.

Connections: See [A.REI.10](#)

Common Misconceptions: See [A.REI.10](#)

Explanations and Examples: A.REI.11

In Algebra 1, focus on cases where $f(x)$ and $g(x)$ are linear, quadratic and exponential. In Algebra 2 extend this standard to include higher-order polynomials, rational, radical, absolute value and exponential functions.

Students need to understand that numerical solution methods (data in a table used to approximate an algebraic function) and graphical solution methods may produce approximate solutions, and algebraic solution methods produce precise solutions that can be represented graphically or numerically. Students may use graphing calculators or programs to generate tables of values, graph, or solve a variety of functions.

Examples:

- Given the following equations determine the x -value that results in an equal output for both functions.

$$f(x) = 3x - 2$$

$$g(x) = (x + 3)^2 - 1$$

- Graph the following system and give the solutions for $f(x) = g(x)$.

$$f(x) = |x + 2|$$

$$g(x) = -\frac{1}{3}x + \frac{2}{3}$$

- Graph the following system and approximate the solutions for $f(x) = g(x)$.

$$f(x) = \frac{x + 4}{2 - x}$$

$$g(x) = x^3 - 6x^2 + 3x + 10$$

Instructional Strategies: See [A.REI.10](#)

Algebra: Reasoning with Equations and Inequalities [\(A-REI\)](#)

Cluster: *Represent and solve equations and inequalities graphically.*

Standard: A.REI.12 Graph the solutions to a linear inequality in two variables as a half-plane (excluding the boundary in the case of a strict inequality), and graph the solution set to a system of linear inequalities in two variables as the intersection of the corresponding half-planes.

Suggested Standards for Mathematical Practice (MP):

MP.4 Model with mathematics.

MP.5 Use appropriate tools strategically.

Connections: See [A.REI.10](#)

Common Misconceptions: See [A.REI.10](#)

Explanations and Examples: A.REI.12

Students may use graphing calculators, programs or applets to model and find solutions for inequalities or systems of inequalities.

Examples:

- Graph the solution: $y \leq 2x + 3$.
- A publishing company publishes a total of no more than 100 magazines every year. At least 30 of these are women's magazines, but the company always publishes at least as many women's magazines as men's magazines. Find a system of inequalities that describes the possible number of men's and women's magazines that the company can produce each year consistent with these policies. Graph the solution set.
- Graph the system of linear inequalities below and determine if $(3, 2)$ is a solution to the system.

$$\begin{cases} x - 3y > 0 \\ x + y \leq 2 \\ x + 3y > -3 \end{cases}$$

Solution:

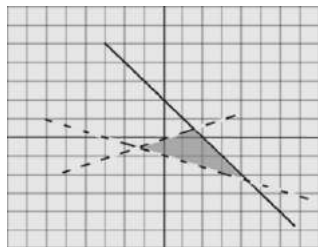

$(3, 2)$ is not an element of the solution set (graphically or by substitution).

Continued on next page

Explanations and Examples: A.REI.12

- The coordinate grid shows points A through J.

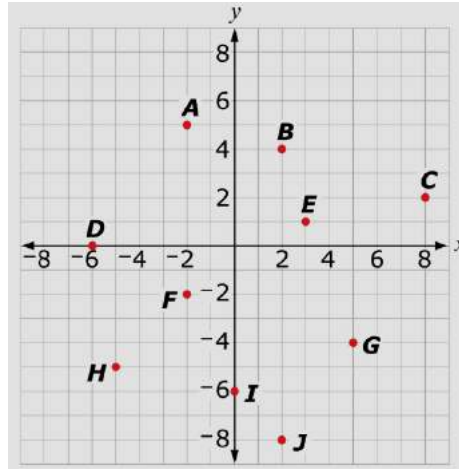

Given the system of inequalities shown below, name all the points that are solutions to this system of inequalities.

$$\begin{cases} x + y < 3 \\ 2x - y > 6 \end{cases}$$

Solution: points G and J

- Graph this system of inequalities on the given coordinate grid.

$$\begin{cases} x + y \geq 12 \\ 20x + 30y \leq 300 \end{cases}$$

To create a line, click in the grid to create the first point on the line. To create the second point on the line, move the pointer and click. The line will be automatically drawn between the two points. Use the same process to create additional lines.

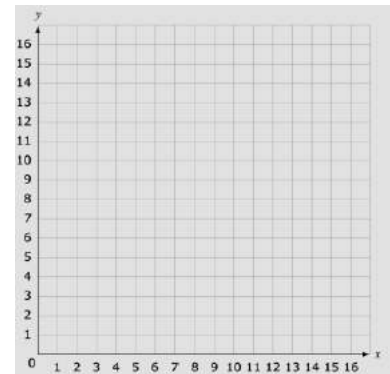

When both inequalities are graphed, select the region in your graph that represents the solution to this system of inequalities. To select a region, click anywhere in the region. To clear a selected region, click anywhere in the selected region.

Solution:

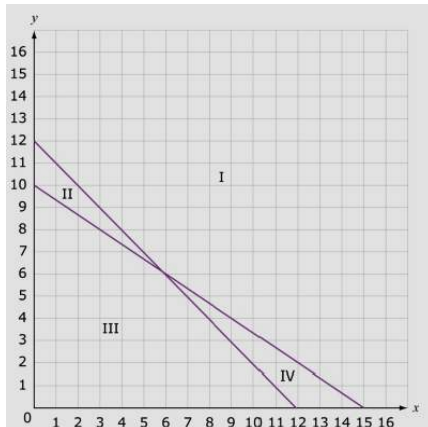

One line contains points (12, 0) and (0, 12), the other line contains the points (15,0) and (0, 10). Region IV represents the solution to the system of inequalities.

Instructional Strategies: See [A.REI.10](#)

Conceptual Category Functions

Functions describe situations where one quantity determines another. For example, the return on \$10,000 invested at an annualized percentage rate of 4.25% is a function of the length of time the money is invested. Because we continually make theories about dependencies between quantities in nature and society, functions are important tools in the construction of mathematical models.

In school mathematics, functions usually have numerical inputs and outputs and are often defined by an algebraic expression. For example, the time in hours it takes for a car to drive 100 miles is a function of the car's speed in miles per hour, v ; the rule $T(v) = 100/v$ expresses this relationship algebraically and defines a function whose name is T .

The set of inputs to a function is called its domain. We often infer the domain to be all inputs for which the expression defining a function has a value, or for which the function makes sense in a given context.

A function can be described in various ways, such as by a graph (e.g., the trace of a seismograph); by a verbal rule, as in, "I'll give you a state, you give me the capital city;" by an algebraic expression like $f(x) = a + bx$; or by a recursive rule. The graph of a function is often a useful way of visualizing the relationship of the function models, and manipulating a mathematical expression for a function can throw light on the function's properties.

Functions presented as expressions can model many important phenomena. Two important families of functions characterized by laws of growth are linear functions, which grow at a constant rate, and exponential functions, which grow at a constant percent rate. Linear functions with a constant term of zero describe proportional relationships.

A graphing utility or a computer algebra system can be used to experiment with properties of these functions and their graphs and to build computational models of functions, including recursively defined functions.

Connections to Expressions, Equations, Modeling, and Coordinates.

Determining an output value for a particular input involves evaluating an expression; finding inputs that yield a given output involves solving an equation. Questions about when two functions have the same value for the same input lead to equations, whose solutions can be visualized from the intersection of their graphs. Because functions describe relationships between quantities, they are frequently used in modeling. Sometimes functions are defined by a recursive process, which can be displayed effectively using a spreadsheet or other technology.

Functions				
------------------	--	--	--	--

Functions Standards Overview

Note: The standards identified with a (+) contain additional mathematics that students should learn in order to take advanced courses such as calculus, advanced statistics or discrete mathematics that go beyond the mathematics that all students should study in order to be college- and career-ready. Explanations and examples of these standards are not included in this document.

Modeling Standards: *Specific modeling standards appear throughout the high school standards indicated by a star symbol (★).* [\(RETURN TO PG. 5\)](#)

Interpreting Functions (F-IF)

- *Understand the concept of a function and use function notation.*
[F.IF.1](#) [F.IF.2](#) [F.IF.3](#)
- *Interpret functions that arise in applications in terms of the context. (★)*
[F.IF.4](#) (★) [F.IF.5](#) (★) [F.IF.6](#) (★)
- *Analyze functions using different representations.*
[F.IF.7](#) (★) [F.IF.8](#) [F.IF.9](#)

Building Functions (F-BF)

- *Build a function that models a relationship between two quantities. (★)*
[F.BF.1](#) (★) [F.BF.2](#) (★)
- *Build new functions from existing functions.*
[F.BF.3](#) [F.BF.4](#) F.BF.5 (+)

Linear, Quadratic, and Exponential Models (★) (F-LE)

- *Construct and compare linear, quadratic, and exponential models and solve problems.*
[F.LE.1](#) (★) [F.LE.2](#) (★) [F.LE.3](#) (★) [F.LE.4](#) (★)
- *Interpret expressions for functions in terms of the situation they model.*
[F.LE.5](#) (★)

Trigonometric Functions (F-TF)

- *Extend the domain of trigonometric functions using the unit circle.*
[F.TF.1](#) [F.TF.2](#) F.TF.3 (+) F.TF.4 (+)
- *Model periodic phenomena with trigonometric functions.*
[F.TF.5](#) (★) F.TF.6 (+) F.TF.7 (+) (★)
- *Prove and apply trigonometric identities.*
[F.TF.8](#) F.TF.9 (+)

Functions: Interpreting Functions (F-IF)

Cluster: *Understand the concept of a function and use function notation.*

Standard: F.IF.1 Understand that a function from one set (called the domain) to another set (called the range) assigns to each element of the domain exactly one element of the range. If f is a function and x is an element of its domain, then $f(x)$ denotes the output of f corresponding to the input x . The graph of f is the graph of the equation $y = f(x)$.

Suggested Standards for Mathematical Practice (MP):

MP.2 Reason abstractly and quantitatively.

MP.7 Look for and make use of structure.

MP.6 Attend to precision.

Connections: F.IF.1-3

Understanding a function as a rule that assigns exactly one output to each input is developed in Grade 8. In high school, the idea of a function is expanded to include use of function notation and evaluating functions for given input values.

Explanations and Examples: F.IF.1

Use the definition of a function to determine whether a relationship is a function given a table, graph or words.

Given the function $f(x)$, identify x as an element of the domain, the input, and $f(x)$ is an element in the range, the output. The domain of a function given by an algebraic expression, unless otherwise specified, is the largest possible domain. Know that the graph of the function, f , is the graph of the equation $y = f(x)$.

Students should experience a variety of types of situations modeled by functions. Detailed analysis of any particular class of functions in Algebra 1 is not advised. Students should apply these concepts throughout their future mathematics courses. Draw examples from linear, quadratic, and exponential functions.

Examples:

- Determine which of the following tables represent a function and explain why.

A	
x	$f(x)$
0	1
1	2
2	2
3	4

B	
x	$f(x)$
0	0
1	2
1	3
4	5

Solution: Table A represents a function because for each element in the domain there is exactly one element in the range. Table B does not represent a function because when $x = 1$, there are two values for $f(x)$: 2 and 3.

Continued on next page

Explanations and Examples: F.IF.1

- For the functions a. through f. below:
 - List the algebraic operations in order of evaluation. What restrictions does each operation place on the domain of the function?
 - Give the function's domain.

a. $y = \frac{2}{x-3}$

b. $y = \sqrt{x-5} + 1$

c. $y = 4 - (x-3)^2$

d. $y = \frac{7}{4-(x-3)^2}$

e. $y = 4 - (x-3)^{\frac{1}{2}}$

f. $y = \frac{7}{4 - (x-3)^{\frac{1}{2}}}$

- For numbers 1a – 1d, determine whether each relation is a function.

1a. $\{(0,1), (1,2), (3,1), (4,2)\}$ Yes No

1b. $y = \pm\sqrt{4-x^2}$ Yes No

1c.  Yes No

1d. $\{(5,3), (2,4), (5,2)\}$ Yes No

Solutions:

1a. Yes – All x-coordinates are unique, so it meets the definition of a function.

1b. No – An input of $x = 1$ has two corresponding outputs, $y = \sqrt{3}$ and $y = -\sqrt{3}$, so it fails to meet the definition of a function.

1c. Yes – This is a function since for each value chosen along the x-axis, there is exactly one y-value on the graph that corresponds to it.

1d. No – This is not a function since the input of 5 has two corresponding output values, 3 and 2.

Continued on next page

Instructional Strategies: F.IF.1-3

Provide applied contexts in which to explore functions. For example, examine the amount of money earned when given the number of hours worked on a job, and contrast this with a situation in which a single fee is paid by the “carload” of people, regardless of whether 1, 2, or more people are in the car.

Use diagrams to help students visualize the idea of a function machine. Students can examine several pairs of input and output values and try to determine a simple rule for the function.

Rewrite sequences of numbers in tabular form, where the input represents the term number (the position or index) in the sequence, and the output represents the number in the sequence.

Help students to understand that the word “domain” implies the set of all possible input values and that the integers are a set of numbers made up of {...-2, -1, 0, 1, 2, ...}.

Distinguish between relationships that are not functions and those that are functions (e.g., present a table in which one of the input values results in multiple outputs to contrast with a functional relationship). Examine graphs of functions and non-functions, recognizing that if a vertical line passes through at least two points in the graph, then y (or the quantity on the vertical axis) is not a function of x (or the quantity on the horizontal axis).

Common Misconceptions: F.IF.1-3

Students may believe that all relationships having an input and an output are functions, and therefore, misuse the function terminology.

Students may also believe that the notation $f(x)$ means to multiply some value f times another value x . The notation alone can be confusing and needs careful development. For example, $f(2)$ means the output value of the function f when the input value is 2.

Functions: Interpreting Functions [\(F-IF\)](#)

Cluster: *Understand the concept of a function and use function notation.*

Standard: F.IF.2 Use function notation, evaluate functions for inputs in their domains, and interpret statements that use function notation in terms of a context.

Suggested Standards for Mathematical Practice (MP):

MP.2 Reason abstractly and quantitatively.

MP.7 Look for and make use of structure.

MP.6 Attend to precision.

Connections: See [F.IF.1](#)

Common Misconceptions: See [F.IF.1](#)

Explanations and Examples: F.IF.2

When a relation is determined to be a function, use $f(x)$ notation. Decode function notation and explain how the output of a function is matched to its input (e.g., The function $f(x) = 2x^2 + 4$ squares the input, doubles the square, and adds four to produce the output).

Convert a table, graph, set of ordered pairs, or description into function notation by identifying the rule used to turn inputs into outputs and writing the rule.

Identify the numbers that are not in the domain of a function (e.g., 0 is not in the domain of $g(x) = \frac{1}{x}$ and negative numbers are not in the domain of $h(x) = \sqrt{x}$).

Analyze the input and output values of a function based on a problem situation.

Examples:

- If $f(x) = x^2 + 4x - 12$, find $f(2)$.
- Let $f(x) = 2(x + 3)^2$. Find $f(3)$, $f(-\frac{1}{2})$, $f(a)$, and $f(a - h)$
- If $P(t)$ is the population of Tucson t years after 2000, interpret the statements $P(0) = 487,000$ and $P(10) - P(9) = 5,900$
- You put a yam in the oven. After 45 minutes, you take it out. Let f be the function that assigns to each minute after you placed the yam in the oven, its temperature in degrees Fahrenheit.
 - a. Write a sentence explaining what $f(0) = 65$ means in everyday language
 - b. Write a sentence explaining what $f(5) < f(10)$ means in everyday language.
 - c. Write a sentence explaining what $f(40) = f(45)$ means in everyday language
 - d. Write a sentence explaining what $f(45) > f(60)$ means in everyday language.

Continued on next page

Explanations and Examples: F.IF.2

Sample Response:

- a. $f(0)=65$ means that when you placed the yam in the oven, its temperature was 65 degrees Fahrenheit.
- b. $f(5)<f(10)$ means that the temperature of the yam 5 minutes after you placed it in the oven was less than its temperature 10 minutes after you placed it in the oven. This would be because the yam's temperature will increase from 65 degrees Fahrenheit during the first few minutes its in the oven.
- c. $f(40)=f(45)$ means that the temperature of the yam 40 minutes after you placed it in the oven was the same as its temperature 45 minutes after you placed it in the oven. This would be because the temperature of the yam eventually plateaus.
- d. $f(45)>f(60)$ means that the temperature of the yam 45 minutes after you placed it in the oven was greater than its temperature 60 minutes after you placed it in the oven. This would be because the yam began to cool down after you removed it from the oven.

Instructional Strategies: See [F.IF.1](#)

Functions: Interpreting Functions (F-IF)

Cluster: *Understand the concept of a function and use function notation.*

Standard: F.IF.3 Recognize that sequences are functions, sometimes defined recursively, whose domain is a subset of the integers. *For example, the Fibonacci sequence is defined recursively by $F(0) = F(1) = 1$, $f(n + 1) = f(n) + f(n - 1)$ for $n \geq 1$.*

Suggested Standards for Mathematical Practice (MP):

MP.2 Reason abstractly and quantitatively.

MP.7 Look for and make use of structure.

MP.8 Look for and express regularity in repeated reasoning.

Connections: See [F.IF.1](#)

Common Misconceptions: See [F.IF.1](#)

Explanations and Examples: F.IF.3

In F.IF.3 draw a connection to F.BF.2, which requires students to write arithmetic and geometric sequences. Emphasize arithmetic and geometric sequences as examples of linear and exponential functions.

Students should be able to explain that a recursive formula tells how a sequence starts and how to use the previous value(s) to generate the next element of the sequence.

Students should be able to explain that an explicit formula allows them to find any element of a sequence without knowing the element before it (e.g., If I want to know the 11th number on the list, I substitute the number 11 into the explicit formula).

Students need to be able to distinguish between explicit and recursive formulas for sequences.

Instructional Strategies: See [F.IF.1](#)

Functions: Interpreting Functions (F-IF)

Cluster: *Interpret functions that arise in applications in terms of the context.* (★)

Standard: F.IF.4 For a function that models a relationship between two quantities, interpret key features of graphs and tables in terms of the quantities, and sketch graphs showing key features given a verbal description of the relationship. Key features include: intercepts; intervals where the functions is increasing, decreasing, positive, or negative; relative maxima and minima; symmetries; end behavior; and periodicity. (★)

Suggested Standards for Mathematical Practice (MP):

MP.2 Reason abstractly and quantitatively. MP.6 Attend to precision.
MP.4 Model with mathematics. MP.7 Look for and make use of structure.
MP.5 Use appropriate tools strategically. MP.8 Look for and express regularity in repeated reasoning.

Connections: F.IF.4-6

A basic study of functions takes place in Grade 8, as students examine simple linear and non-linear functions, including the idea that some functions have greater rates of change than others. In high school, more complex functions with inconsistent rates of change and their graphs are examined, including analysis of the domain of a function.

Explanations and Examples: F.IF.4

The expectation at the Algebra I level is for F.IF.4 and F.IF.5 to focus on linear and exponential functions. Later in the year, focus on quadratic functions and compare them with linear and exponential functions. In Algebra 2, students will extend this standard to include higher order polynomials, rational, absolute value, and trigonometric functions.

Given a function, identify key features in graphs and tables including: intercepts; intervals where the function is increasing, decreasing, positive, or negative; relative maximums and minimums; symmetries; end behavior; and periodicity.

Students may be given graphs to interpret or produce graphs given an expression or table for the function, by hand or using technology.

Examples:

- A rocket is launched from 180 feet above the ground at time $t = 0$. The function that models this situation is given by $h = -16t^2 + 96t + 180$, where t is measured in seconds and h is height above the ground measured in feet.
 - What is a reasonable domain restriction for t in this context?
 - Determine the height of the rocket two seconds after it was launched.
 - Determine the maximum height obtained by the rocket.
 - Determine the time when the rocket is 100 feet above the ground.
 - Determine the time at which the rocket hits the ground.
 - How would you refine your answer to the first question based on your response to the second and fifth questions?
- Compare the graphs of $y = 3x^2$ and $y = 3x^3$.

Continued on next page

Explanations and Examples: F.IF.4

- Let $R(x) = \frac{2}{\sqrt{x-2}}$. Find the domain of $R(x)$. Also find the range, zeros, and asymptotes of $R(x)$.
- Let $f(x) = x^2 - 5x + 1$. Graph the function and identify end behavior and any intervals of constancy, increase, and decrease.
- It started raining lightly at 5am, then the rainfall became heavier at 7am. By 10am the storm was over, with a total rainfall of 3 inches. It didn't rain for the rest of the day.
Sketch a possible graph for the number of inches of rain as a function of time, from midnight to midday.

Instructional Strategies: F.IF.4-6

Flexibly move from examining a graph and describing its characteristics (e.g., intercepts, relative maximums, etc.) to using a set of given characteristics to sketch the graph of a function.

Examine a table of related quantities and identify features in the table, such as intervals on which the function increases, decreases, or exhibits periodic behavior.

Recognize appropriate domains of functions in real-world settings. For example, when determining a weekly salary based on hours worked, the hours (input) could be a rational number, such as 25.5. However, if a function relates the number of cans of soda sold in a machine to the money generated, the domain must consist of whole numbers.

Given a table of values, such as the height of a plant over time, students can estimate the rate of plant growth. Also, if the relationship between time and height is expressed as a linear equation, students should explain the meaning of the slope of the line. Finally, if the relationship is illustrated as a linear or non-linear graph, the student should select points on the graph and use them to estimate the growth rate over a given interval.

Begin with simple, linear functions to describe features and representations, and then move to more advanced functions, including non-linear situations.

Provide students with many examples of functional relationships, both linear and non-linear. Use real-world examples, such as the growth of an investment fund over time, so that students can not only describe what they see in a table, equation, or graph, but also can relate the features to the real-life meanings.

Allow students to collect their own data sets, such as the falling temperature of a glass of hot water when removed from a flame versus the amount of time, to generate tables and graphs for discussion and interpretation.

Common Misconceptions: F.IF.4-6

Students may believe that it is reasonable to input any x -value into a function, so they will need to examine multiple situations in which there are various limitations to the domains.

Students may also believe that the slope of a linear function is merely a number used to sketch the graph of the line. In reality, slopes have real-world meaning, and the idea of a rate of change is fundamental to understanding major concepts from geometry to calculus.

Functions: Interpreting Functions (F-IF)

Cluster: *Interpret functions that arise in applications in terms of the context.* (★)

Standard: F.IF.5 Relate the domain of a function to its graph and, where applicable, to the quantitative relationship it describes. *For example, if the function $h(n)$ gives the number of person-hours it takes to assemble n engines in a factory, then the positive integers would be an appropriate domain for the function.* (★)

Suggested Standards for Mathematical Practice (MP):

MP.2 Reason abstractly and quantitatively.
MP.6 Attend to precision.

MP.4 Model with mathematics.

Connections: See [F.IF.4](#)

Common Misconceptions: See [F.IF.4](#)

Explanations and Examples: F.IF.5

The expectation at the Algebra I level is for F.IF.4 and F.IF.5 to focus on linear and exponential functions. Later in the year, focus on quadratic functions and compare them with linear and exponential functions. In Algebra 2, students will extend this standard to include higher order polynomials, rational, absolute value, and trigonometric functions.

Given the graph of a function, determine the practical domain of the function as it relates to the numerical relationship it describes.

Students may explain orally or in written format, the existing relationships.

Examples:

- If the function $h(n)$ gives the number of person-hours it takes to assemble n engines in a factory, then the positive integers would be an appropriate domain for the function.
- A hotel has 10 stories above ground and 2 levels in its parking garage below ground. What is an appropriate domain for a function $T(n)$ that gives the average number of times an elevator in the hotel stops at the n^{th} floor each day?
- Oakland Coliseum, home of the Oakland Raiders, is capable of seating 63,026 fans. For each game, the amount of money that the Raiders' organization brings in as revenue is a function of the number of people, n , in attendance. If each ticket costs \$30, find the domain and range of this function.

Sample Response:

Let r represent the revenue that the Raider's organization makes, so that $r = f(n)$. Since n represents a number of people, it must be a nonnegative whole number. Therefore, since 63,026 is the maximum number of people who can attend a game, we can describe the domain of f as follows:

$$\text{Domain} = \{n: 0 \leq n \leq 63,026 \text{ and } n \text{ is an integer}\}$$

The range of the function consists of all possible amounts of revenue that could be earned. To explore this question, note that $r = 0$ if nobody comes to the game, $r = 30$ if one person comes to the game, $r = 60$ if two people come to the game, etc. Therefore, r must be a multiple of 30 and cannot exceed $30 \cdot 63,026 = 1,890,780$, so we see that $\text{Range} = \{r: 0 \leq r \leq 1,890,780 \text{ and } r \text{ is an integer multiple of } 30\}$.

Continued on next page

Explanations and Examples: F.IF.5

The deceptively simple task above asks students to find the domain and range of a function from a given context. The function is linear and if simply looked at from a formulaic point of view, students might find the formula for the line and say that the domain and range are all real numbers. However, in the context of this problem, this answer does not make sense, as the context requires that all input and output values are non-negative integers, and imposes additional restrictions. This problem could serve different purposes. It's primary purpose is to illustrate that the domain of a function is a property of the function in a specific context and not a property of the formula that represents the function. Similarly, the range of a function arises from the domain by applying the function rule to the input values in the domain. A second purpose would be to illicit and clarify a common misconception, that the domain and range are properties of the formula that represent a function. Finally, the context of the task as written could be used to transition into a more involved modeling problem, finding the Raiders' profit after one takes into account overhead costs, costs per attendee, etc.

Instructional Strategies: See [F.IF.4](#)

Functions: Interpreting Functions (F-IF)

Cluster: *Interpret functions that arise in applications in terms of the context.* (★)

Standard: F.IF.6 Calculate and interpret the average rate of change of a function (presented symbolically or as a table) over a specified interval. Estimate the rate of change from a graph. (★)

Suggested Standards for Mathematical Practice (MP):

MP.2 Reason abstractly and quantitatively.

MP.5 Use appropriate tools strategically.

MP.4 Model with mathematics.

Connections: See [F.IF.4](#)

Common Misconceptions: See [F.IF.4](#)

Explanations and Examples: F.IF.6

In Algebra 1 start F.IF.6 by focusing on linear and exponential functions whose domain is a subset of the integers. Later in the year, focus on quadratic functions and compare them with linear and exponential functions. In Algebra 2, students will extend this standard to address other types of functions.

The average rate of change of a function $y = f(x)$ over an interval $[a, b]$ is $\frac{\Delta y}{\Delta x} = \frac{f(b) - f(a)}{b - a}$.

In addition to finding average rates of change from functions given symbolically, graphically, or in a table. Students may collect data from experiments or simulations (such as a falling ball, velocity of a car, etc.) and find average rates of change for the function modeling the situation.

Examples:

- Use the following table to find the average rate of change of g over the intervals $[-2, -1]$ and $[0, 2]$:

x	$g(x)$
-2	2
-1	-1
0	-4
2	-10

- The table below shows the elapsed time when two different cars pass a 10, 20, 30, 40 and 50 meter mark on a test track.
 - For car 1, what is the average velocity (change in distance divided by change in time) between the 0 and 10 meter mark? Between the 0 and 50 meter mark? Between the 20 and 30 meter mark? Analyze the data to describe the motion of car 1.
 - How does the velocity of car 1 compare to that of car 2?

	Car 1	Car 2
d	t	t
10	4.472	1.742
20	6.325	2.899
30	7.746	3.831
40	8.944	4.633
50	10	5.348

Continued on next page

Explanations and Examples: F.IF.6

- The value of an antique has increased exponentially, as shown in this graph.

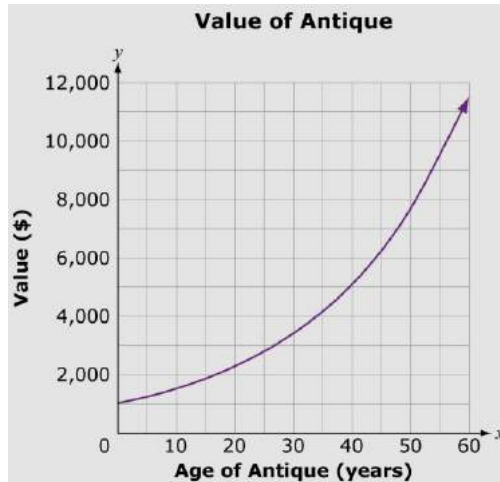

Based on the graph, estimate to the nearest \$50 the average rate of change in value of the antique for the following time intervals:

from 0 to 20 years \$

from 20 to 40 years \$

Solution: 0 to 20 years; 100
20 to 40 years; 150

Instructional Strategies: See [F.IF.4](#)

Functions: Interpreting Functions (F-IF)

Cluster: *Analyze functions using different representations.*

Standard: F.IF.7 Graph functions expressed symbolically and show key features of the graph, by hand in simple cases and using technology for more complicated cases. (★)

- Graph linear and quadratic functions and show intercepts, maxima, and minima.
- Graph square root, cube root, and piecewise-defined functions, including step functions and absolute value functions.
- Graph polynomial functions, identifying zeros when suitable factorizations are available, and showing end behavior.
- (+) Graph rational functions, identifying zeros and asymptotes when suitable factorizations are available, and showing end behavior.
- Graph exponential and logarithmic functions, showing intercepts and end behavior, and trigonometric functions, showing period, midline, and amplitude.

Suggested Standards for Mathematical Practice (MP):

MP.5 Use appropriate tools strategically.

MP.6 Attend to precision.

Connections: F.IF.7-9

In Grade 7, students are exposed to the idea that rewriting an expression can shed light on the meaning of the expression. This idea is expanded upon as students explore functions in high school and recognize how the form of the equation can provide clues about zeros, asymptotes, etc.

Explanations and Examples: F.IF.7

The expectation is for F.IF.7a & 7e to focus on linear and exponential functions in Algebra I. Include comparisons of two functions presented algebraically. For example, compare the growth of two linear functions, or two exponential functions. In Algebra I for F.IF.7b, compare and contrast absolute value, step and piecewise-defined functions with linear, quadratic, and exponential functions. Highlight issues of domain, range, and usefulness when examining piecewise-defined functions. In Algebra 2, relate F.IF.7c to the relationship between zeros of quadratic functions and their factored forms and focus on applications and how key features relate to characteristics of a situation, making selection of a particular type of function model appropriate.

Key characteristics include but are not limited to maxima, minima, intercepts, symmetry, end behavior, and asymptotes. Students may use graphing calculators or programs, spreadsheets, or computer algebra systems to graph functions.

Examples:

- Describe key characteristics of the graph of $f(x) = |x - 3| + 5$.
- Sketch the graph and identify the key characteristics of the function described below:

$$F(x) = \begin{cases} x + 2 & \text{for } x \geq 0 \\ -x^2 & \text{for } x < -1 \end{cases}$$

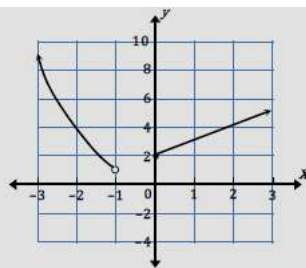

Continued on next page

Explanations and Examples: F.IF.7

- Graph the function $f(x) = 2x$ by creating a table of values. Identify the key characteristics of the graph.
- Graph $f(x) = 2 \tan x - 1$. Describe its domain, range, intercepts, and asymptotes.
- Draw the graph of $f(x) = \sin x$ and $f(x) = \cos x$. What are the similarities and differences between the two graphs?

Instructional Strategies: F.IF.7-9

Explore various families of functions and help students to make connections in terms of general features. For example, just as the function $y = (x + 3)^2 - 5$ represents a translation of the function $y = x^2$ by 3 units to the left and 5 units down, the same is true for the function $y = |x + 3| - 5$ as a translation of the absolute value function $y = |x|$.

Discover that the factored form of a quadratic or polynomial equation can be used to determine the zeros, which in turn can be used to identify maxima, minima and end behaviors.

Use various representations of the same function to emphasize different characteristics of that function.

For example, the y -intercept of the function $y = x^2 - 4x - 12$ is easy to recognize as $(0, -12)$. However, rewriting the function as $y = (x - 6)(x + 2)$ reveals zeros at $(6, 0)$ and at $(-2, 0)$. Furthermore, completing the square allows the equation to be written as $y = (x - 2)^2 - 16$, which shows that the vertex (and minimum point) of the parabola is at $(2, -16)$.

Examine multiple real-world examples of exponential functions so that students recognize that a base between 0 and 1 (such as an equation describing depreciation of an automobile [$f(x) = 15,000(0.8)^x$ represents the value of a \$15,000 automobile that depreciates 20% per year over the course of x years]) results in an exponential decay, while a base greater than 1 (such as the value of an investment over time [$f(x) = 5,000(1.07)^x$ represents the value of an investment of \$5,000 when increasing in value by 7% per year for x years]) illustrates growth.

Graphing utilities on a calculator and/or computer can be used to demonstrate the changes in behavior of a function as various parameters are varied.

Real-world problems, such as maximizing the area of a region bound by a fixed perimeter fence, can help to illustrate applied uses of families of functions.

Common Misconceptions: F.IF.7-9

Students may believe that each family of functions (e.g., quadratic, square root, etc.) is independent of the others, so they may not recognize commonalities among all functions and their graphs.

Students may also believe that skills such as factoring a trinomial or completing the square are isolated within a unit on polynomials, and that they will come to understand the usefulness of these skills in the context of examining characteristics of functions.

Additionally, student may believe that the process of rewriting equations into various forms is simply an algebra symbol manipulation exercise, rather than serving a purpose of allowing different features of the function to be exhibited.

Functions: Interpreting Functions (F-IF)

Cluster: Analyze functions using different representations.

Standard: F.IF.8 Write a function defined by an expression in different but equivalent forms to reveal and explain different properties of the function.

- Use the process of factoring and completing the square in a quadratic function to show zeros, extreme values and symmetry of the graph, and interpret these in terms of a context.
- Use the properties of exponents to interpret expressions for exponential functions. For example, *identify percent rate of change in functions such as $y = (1.02)^t$, $y = (0.97)^t$, $y = (1.01)^{12t}$, $y = (1.2)^{t/10}$, and classify them as representing exponential growth or decay.*

Suggested Standards for Mathematical Practice (MP):

MP.2 Reason abstractly and quantitatively.

MP.7 Look for and make use of structure.

Connections: See [F.IF.7](#)

Common Misconceptions: See [F.IF.7](#)

Explanations and Examples: F.IF.8

In Algebra 1 focus on this standard with linear, exponential and quadratic functions. In Algebra 2 students will extend their work to focus on applications and how key features relate to characteristics of a situation making selection of a particular type of function.

Examples:

- Factor the following quadratic to identify its zeros: $x^2 + 2x - 8 = 0$
- Complete the square for the quadratic and identify its vertex: $x^2 + 6x + 19 + 0$
- Write the following function in a different form and explain what each form tells you about the function:
 $f(x) = x^3 - 6x^2 + 3x + 10$
- Write the function $y - 3 = \frac{2}{3}(x-4)$ in the equivalent form most appropriate for identifying the slope and y-intercept of the function.

Solution: $y = \frac{2}{3}x + \frac{1}{3}$

- Which of the following equations could describe the function of the given graph? Explain.

$$f_1(x) = (x + 12)^2 + 4$$

$$f_2(x) = -(x - 2)^2 - 1$$

$$f_3(x) = (x + 18)^2 - 40$$

$$f_4(x) = (x - 10)^2 - 15$$

$$f_5(x) = -4(x + 2)(x + 3)$$

$$f_6(x) = (x + 4)(x - 6)$$

$$f_7(x) = (x - 12)(-x + 18)$$

$$f_8(x) = (20 - x)(30 - x)$$

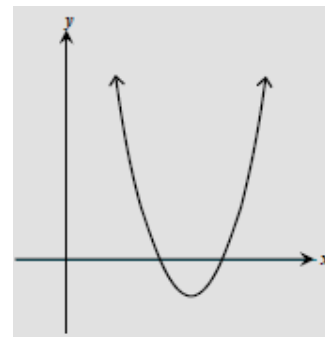

Continued on next page

Explanations and Examples: F.IF.8

Solution: All of these equations describe quadratic functions. Since quadratic functions have graphs that are parabolas and the given graph appears to be a parabola, the given equations meet a minimum criteria for consideration.

The graph of $f_1(x) = (x + 12)^2 + 4$ has a vertex of $(-12, 4)$ which is in the second quadrant, so it does not match the graph.

The graph of $f_2(x) = -(x - 2)^2 - 1$ has maximum rather than a minimum value at $x = 2$ since the leading coefficient is negative (in other words, the graph opens downward), so it does not match the graph.

The graph of $f_3(x) = (x + 18)^2 - 40$ has a vertex of $(-18, -40)$ which is in the third quadrant, so it does not match the graph.

The graph of $f_4(x) = (x - 10)^2 - 15$ has a vertex of $(10, -15)$ which is in the fourth quadrant, and the leading coefficient is positive (so the graph would open upward) so this could describe the function whose graph is given.

The graph of $f_5(x) = -4(x + 2)(x + 3)$ has x -intercepts of $(-2, 0)$ and $(-3, 0)$. Since the x -intercepts are both positive for the given graph, they do not match.

The graph of $f_6(x) = (x + 4)(x - 6)$ has x -intercepts of $(-4, 0)$ and $(6, 0)$. The x -intercepts are both positive for the give graph, so they do not match.

The graph of $f_7(x) = (x - 12)(-x + 18)$ has a leading coefficient that is negative and so has a maximum rather than a minimum value (at $x = 15$) and thus cannot match the graph.

The graph of $f_8(x) = (x - 20)(x - 30)$ has x -intercepts of $(20, 0)$ and $(30, 0)$. Since the x -intercepts are both positive for the graph and the leading coefficient is positive (so the graph would open upward), this could possibly be the equation for this graph.

The functions f_4 and f_8 both have graphs of the approximate shape given, though we note that they certainly would not appear identical if plotted simultaneously. For example, the vertex of the graph of f_4 occurs at $x = 10$ whereas that of f_8 occurs at $x = 25$.

- The projected population of Delroyville is given by the formula $p(t) = 1500(1.08)^t$. You have been selected by the city council to help them plan for future growth. Explain what the formula $p(t) = 1500(1.08)^t$ means to the city council members.
- Which of the following functions will represent \$500 placed into a mutual fund yielding 10% per year for 4 years
 - a. $A = 500(.10)^4$
 - b. $A = 500(1.1)^4$
 - c. $A = 500(4)(.10)$
 - d. $A = 500(1.04)^{10}$

Instructional Strategies: See [F.IF.7](#)

Functions: Interpreting Functions (F-IF)

Cluster: *Analyze functions using different representations.*

Standard: F.IF.9 Compare properties of two functions each represented in a different way (algebraically, graphically, numerically in tables, or by verbal descriptions). For example, given a graph of one quadratic function and an algebraic expression for another, say which has the larger maximum.

Suggested Standards for Mathematical Practice (MP):

MP.6 Attend to precision.

MP.7 Look for and make use of structure.

Connections: See [F.IF.7](#)

Common Misconceptions: See [F.IF.7](#)

Explanations and Examples: F.IF.9

Start F.IF.9 by focusing on linear and exponential functions. Include comparisons of two functions presented algebraically. Focus on expanding the types of functions to include linear exponential and quadratic. Extend work with quadratics to include the relationship between coefficients and roots, and once roots are known, a quadratic equation can be factored.

Compare the key features of two functions represented in different ways. For example, compare the end behavior of two functions, one of which is represented graphically and the other is represented symbolically.

Examples:

- Examine the functions below. Which function has the larger maximum? How do you know?

$$f(x) = 2x^2 - 8x + 20$$

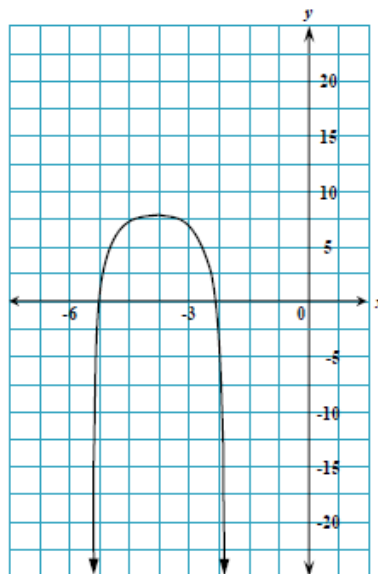

Instructional Strategies: See [F.IF.7](#)

Functions: Building Functions (F-BF)

Cluster: *Build a function that models a relationship between two quantities.* (★)

Standard: F.BF.1 Write a function that describes a relationship between two quantities. (★)

- Determine an explicit expression, a recursive process, or steps for calculation from a context.
- Combine standard function types using arithmetic operations. *For example, build a function that models the temperature of a cooling body by adding a constant function to a decaying exponential and relate these functions to the model.*

Suggested Standards for Mathematical Practice (MP):

MP.1 Make sense of problems and persevere in solving them. MP.6 Attend to precision.
MP.2 Reason abstractly and quantitatively. MP.7 Look for and make use of structure.
MP.3 Construct viable arguments and critique the reasoning of others.
MP.4 Model with mathematics. MP.8 Look for and express regularity in repeated reasoning.
MP.5 Use appropriate tools strategically.

Connections: F.BF.1-2

In Grade 8, students compare functions by looking at equations, tables and graphs, and focus primarily on linear relationships. In high school, examination of functions is extended to include recursive and explicit representations and sequences of numbers that may not have a linear relationship.

Explanations and Examples: F.BF.1

In Algebra 1 focus on situations that exhibit linear, exponential and quadratic relationships. In Algebra 2 develop models for more sophisticated situations.

From context, write an explicit expression, define a recursive process, or describe the calculations need to model a function between two quantities.

Students will analyze a given problem to determine the function expressed by identifying patterns in the function's rate of change. They will specify intervals of increase, decrease, constancy, and, if possible, relate them to the function's description in words or graphically. Students may use graphing calculators or programs, spreadsheets, or computer algebra systems to model functions.

Examples:

- You buy a \$10,000 car with an annual interest rate of 6% compounded annually and make monthly payments of \$250. Express the amount remaining to be paid off as a function of the number of months, using a recursion equation.
- A cup of coffee is initially at a temperature of 93° F. The difference between its temperature and the room temperature of 68° F decreases by 9% each minute.
Write a function describing the temperature of the coffee as a function of time.
- The radius of a circular oil slick after t hours is given in feet by $r = 10t^2 - 0.5t$, for $0 \leq t \leq 10$.
Find the area of the oil slick as a function of time.

Continued on next page

Explanations and Examples: F.BF.1

- You are making an open box out of a rectangular piece of cardboard with dimensions 40 cm by 30 cm, by cutting equal squares out of the four corners and then folding up the sides. How big should the squares be to maximize the volume of the box? Draw a diagram to represent the problem and write an appropriate equation to solve.
- A new social networking website was made available. The website had 10 members its first week. Beginning the second week, the creators of the website have a goal to triple the number of members every week.

For *Part A* and *Part B* below, select the appropriate expression for each blank region.

To place an expression in a region, click on the expression, move the pointer over the region, and click again to place the expression in the region. Only one expression can be placed in each region. To return all expressions to their original positions, click the Reset button.

0	1	3	7	10
$3n+7$	$3n+10$	$30(n-1)$	$10(3^{n-1})$	$3(10^{n-1})$
$f(n-1)+2$	$f(n-1)+30$	$3f(n-1)$	$3f(n-1)+10$	$f(3n-1)$

Part A

Determine an explicit formula for $f(n)$, the number of members the creators have a goal of getting n weeks after the website is made available.

$$f(n) = \boxed{}$$

Part B

Determine a recursive formula for $f(n)$.

$$f(n) = \boxed{} \quad \text{for } n > \boxed{}$$

$$f(1) = \boxed{}$$

Solution: Part A: $f(n) = 10(3^{n-1})$

Part B: $f(n) = 3f(n-1)$ for $n > 1$

$$f(1) = 10$$

Continued on next page

Instructional Strategies: F.BF.1-2

Provide a real-world example (e.g., a table showing how far a car has driven after a given number of minutes, traveling at a uniform speed), and examine the table by looking “down” the table to describe a recursive relationship, as well as “across” the table to determine an explicit formula to find the distance traveled if the number of minutes is known.

Write out terms in a table in an expanded form to help students see what is happening. For example, if the y -values are 2, 4, 8, 16, they could be written as 2, $2(2)$, $2(2)(2)$, $2(2)(2)(2)$, etc., so that students recognize that 2 is being used multiple times as a factor.

Focus on one representation and its related language – recursive or explicit – at a time so that students are not confusing the formats.

Provide examples of when functions can be combined, such as determining a function describing the monthly cost for owning two vehicles when a function for the cost of each (given the number of miles driven) is known.

Using visual approaches (e.g., folding a piece of paper in half multiple times), use the visual models to generate sequences of numbers that can be explored and described with both recursive and explicit formulas. Emphasize that there are times when one form to describe the function is preferred over the other.

Hands-on materials (e.g., paper folding, building progressively larger shapes using pattern blocks, etc.) can be used as a visual source to build numerical tables for examination.

Common Misconceptions: F.BF.1-2

Students may believe that the best (or only) way to generalize a table of data is by using a recursive formula.

Students naturally tend to look “down” a table to find the pattern but need to realize that finding the 100th term requires knowing the 99th term unless an explicit formula is developed.

Students may also believe that arithmetic and geometric sequences are the same. Students need experiences with both types of sequences to be able to recognize the difference and more readily develop formulas to describe them.

Functions: Building Functions [\(F-BF\)](#)

Cluster: *Build a function that models a relationship between two quantities.* (★)

Standard: F.BF.2 Write arithmetic and geometric sequences both recursively and with an explicit formula; use them to model situations, and translate between the two forms. (★)

Suggested Standards for Mathematical Practice (MP):

MP.4 Model with mathematics.

MP.7 Look for and make use of structure.

MP.5 Use appropriate tools strategically.

MP.8 Look for and express regularity in repeated reasoning.

Connections: See [F.BF.1](#)

Common Misconceptions: See [F.BF.1](#)

Explanations and Examples: F.BF.2

Connect arithmetic sequences to linear functions and geometric sequences to exponential functions. Students should understand that linear functions are the explicit form of recursively-defined arithmetic sequences and that exponential functions are the explicit form of recursively-defined geometric sequence.

Explain why the recursive formula for an arithmetic sequence uses addition and the explicit formula uses multiplication.

Explain why the recursive formula for a geometric sequence uses multiplication and why the explicit formula uses exponentiation.

Decide when a real world problem models a geometric sequence and write an equation to model the situation.

An explicit rule for the n^{th} term of a sequence gives a_n as an expression in the term's position n ; a recursive rule gives the first term of a sequence, and a recursive equation relates a_n to the preceding term(s). Both methods of presenting a sequence describe a_n as a function of n .

Examples:

- Generate the 5th–11th terms of a sequence if $A_1 = 2$ and $A_{(n+2)} = (A_n)^2 - 1$.
- Use the formula: $A_n = A_1 + d(n - 1)$ where d is the common difference to generate a sequence whose first three terms are: $-7, -4$ and -1 .
- There are 2,500 fish in a pond. Each year the population decreases by 25 percent, but 1,000 fish are added to the pond at the end of the year. Find the population in five years. Also, find the long-term population.
- Given the formula $A = 2n - 1$, find the 17th term of the sequence.
What is the 9th term in the sequence 3, 5, 7, 9, ...?
- Given $a_1 = 4$ and $a_n = a_{n-1} + 3$, write the explicit formula.

Continued on next page

Explanations and Examples: F.BF.2

- The first four terms of a sequence are shown below.

8, 12, 18, 27, ...

Write a recursive function for this sequence.

Solution: $f(n) = \frac{3}{2} \cdot f(n-1)$ for $n > 1$, where $f(1) = 8$

- A company purchases \$24,500 of new computer equipment. For tax purposes, the company estimates that the equipment decreases in value by the same amount each year. After 3 years, the estimated value is \$9800.

Write an explicit function that gives the estimated value of the computer equipment n years after purchase.

Solution: $f(n) = 24,500 - 4900n$

Instructional Strategies: See **F.BF.1**

Functions: Building Functions (F-BF)

Cluster: *Build new functions from existing functions.*

Standard: F.BF.3 Identify the effect on the graph of replacing $f(x)$ by $f(x) + k$, $k f(x)$, $f(kx)$, and $f(x + k)$ for specific values of k (both positive and negative); find the value of k given the graphs. Experiment with cases and illustrate an explanation of the effects on the graph using technology. *Include recognizing even and odd functions from their graphs and algebraic expressions for them.*

Suggested Standards for Mathematical Practice (MP):

MP.4 Model with mathematics.

MP.7 Look for and make use of structure.

MP.5 Use appropriate tools strategically.

Connections: F.BF.3-4a

Understanding functional relationships as input and output values that have an associated graph is introduced in Grade 8. In high school, changes in graphs is explored in more depth, and the idea of functions having inverses is introduced.

Explanations and Examples: F.BF.3

In Algebra 1 start by focusing on vertical translations of graphs of linear and exponential functions. Relate the vertical translation of a linear function to its y -intercept. While applying other transformations to a linear graph is appropriate at this level, it may be difficult for students to identify or distinguish between the effects of the other transformations included in this standard. Extend to quadratic functions when appropriate and consider including absolute value functions. In Algebra 2 use transformations of functions to find models as students consider increasingly more complex situations. Note the effect of multiple transformations on a single graph and the common effect of each transformation across function types.

Students will apply transformations to functions and recognize functions as even and odd. Students may use graphing calculators or programs, spreadsheets, or computer algebra systems to graph functions.

Analyze the similarities and differences of between functions with different k values.

Examples:

- Is $f(x) = x^3 - 3x^2 + 2x + 1$ even, odd, or neither? Explain your answer orally or in written format.
- Compare the shape and position of the graphs of $f(x) = x^2$ and $g(x) = 2x^2$, and explain the differences in terms of the algebraic expressions for the functions.

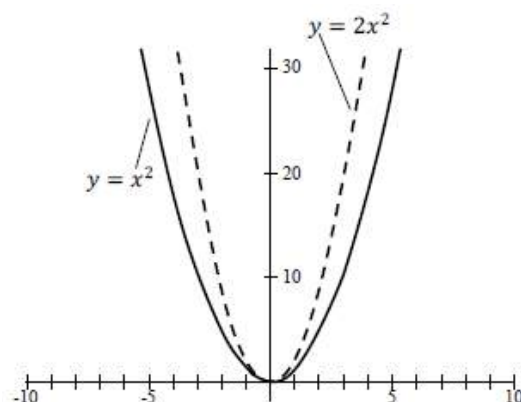

Continued on next page

Explanations and Examples: F.BF.3

- Compare the graphs of $f(x) = 3x$ with those of $g(x) = 3x + 2$ and $h(x) = 3x - 1$ to see that parallel lines have the same slope and to explore the effect of the transformation of the function, $f(x) = 3x$ such that $g(x) = f(x) + 2$ and $h(x) = f(x) - 1$.
- Explore the relationship between $f(x) = 3$, $g(x) = 5x$, and $h(x) = \frac{1}{2}x$ with a calculator to develop a relationship between the coefficient on x and the slope.
- Describe the effect of varying the parameters a , h , and k on the shape and position of the graph $f(x) = a(x - h)^2 + k$.
- Compare the shape and position of the graphs of $f(x) = e^x$ to $g(x) = e^{x-6} + 5$, and explain the differences, orally or in written format, in terms of the algebraic expressions for the functions

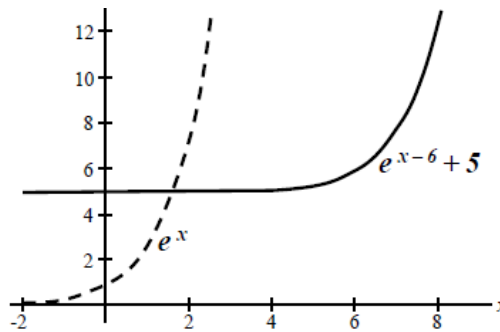

- Describe the effect of varying the parameters a , h , and k on the shape and position of the graph $f(x) = ab^{(x+h)} + k$ orally or in written format. How do the values between 0 and 1 effect the graph? What is the effect of negative values on the graph?
- Compare the shape and position of the graphs of $y = \sin x$ to $y = 2 \sin x$.

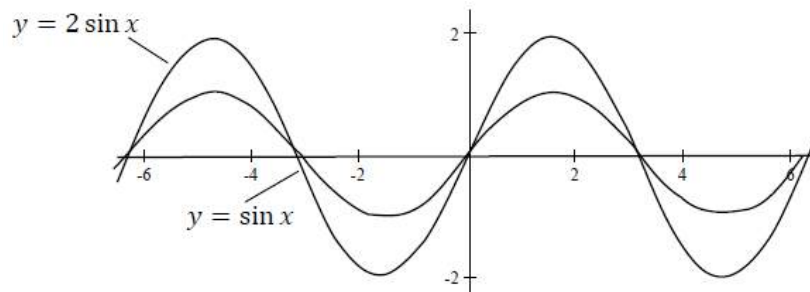

Continued on next page

Instructional Strategies: F.BF.3-4

Use graphing calculators or computers to explore the effects of a constant in the graph of a function.

For example, students should be able to distinguish between the graphs of $y = x^2$, $y = 2x^2$, $y = x^2 + 2$, $y = (2x)^2$, and $y = (x + 2)^2$. This can be accomplished by allowing students to work with a single parent function and examine numerous parameter changes to make generalizations.

Distinguish between even and odd functions by providing several examples and helping students to recognize that a function is even if $f(-x) = f(x)$ and is odd if $f(-x) = -f(x)$. Visual approaches to identifying the graphs of even and odd functions can be used as well.

Provide examples of inverses that are not purely mathematical to introduce the idea. For example, given a function that names the capital of a state, $f(\text{Ohio}) = \text{Columbus}$. The inverse would be to input the capital city and have the state be the output, such that $f^{-1}(\text{Denver}) = \text{Colorado}$.

Common Misconceptions: F.BF.3-4

Students may believe that the graph of $y = (x - 4)^3$ is the graph of $y = x^3$ shifted 4 units to the left (due to the subtraction symbol). Examples should be explored by hand and on a graphing calculator to overcome this misconception.

Students often confuse the shift of a function with the stretch of a function.

Students may also believe that *even* and *odd* functions refer to the exponent of the variable, rather than the sketch of the graph and the behavior of the function.

Additionally, students may believe that all functions have inverses and need to see counter examples, as well as examples in which a non-invertible function can be made into an invertible function by restricting the domain.

For example, $f(x) = x^2$ has an inverse ($f^{-1}(x) = \sqrt{x}$) provided that the domain is restricted to $x \geq 0$.

Functions: Building Functions (F-BF)

Cluster: *Build new functions from existing functions.*

Standard: F.BF.4 Find inverse functions.

- a. Solve an equation of the form $f(x) = c$ for a simple function f that has an inverse and write an expression for the inverse. For example, $f(x) = 2x^3$ for $x > 0$ or $f(x) = \frac{(x+1)}{(x-1)}$ for $x \neq 1$.

Suggested Standards for Mathematical Practice (MP):

MP.2 Reason abstractly and quantitatively.
MP.4 Model with mathematics.

MP.5 Use appropriate tools strategically.
MP.7 Look for and make use of structure.

Connections: See [F.BF.3](#)

Common Misconceptions: See [F.BF.3](#)

Explanations and Examples: F.BF.4

For F.BF.4a focus on linear functions but consider simple situations where the domain of the functions must be restricted in order for the inverses to exist, such as $f(x) = x^2, x > 0$. This work will be extended in Algebra 2 to include simple rational, simple radical and simple exponential functions.

Solve a function for the dependent variable and write the inverses of a function by interchanging the values of the dependent and independent variable.

Students may use graphing calculators or programs, spreadsheets or computer algebra systems to model functions.

Examples:

- Draw the graph of the inverse of $f(x) = -\frac{3}{2}x - 3$ on the coordinate grid below.

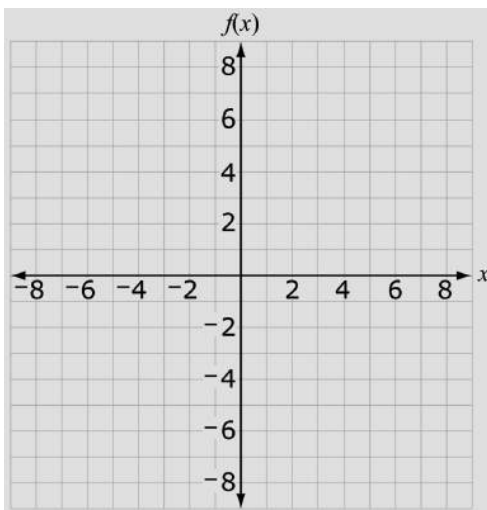

Solution:

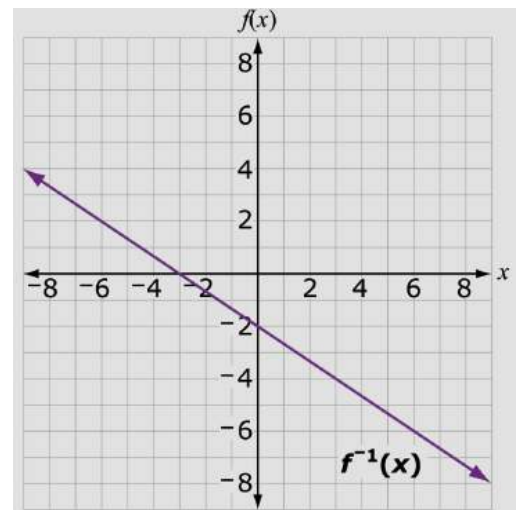

Continued on next page

Explanations and Examples: F.BF.4

- For the function $h(x) = (x - 2)^3$, defined on the domain of all real numbers, find the inverse function if it exists or explain why it does not exist.
- Graph $h(x)$ and $h^{-1}(x)$ and explain how they relate to each other graphically and algebraically.
- Find a domain for $f(x) = 3x^2 + 12x - 8$ on which it has an inverse.
Explain why it is necessary to restrict the domain of the function.

Instructional Strategies: F.BF.4

Provide examples of inverses that are not purely mathematical to introduce the idea. For example, given a function that names the capital of a state, $f(\text{Ohio}) = \text{Columbus}$. The inverse would be to input the capital city and have the state be the output, such that $f^{-1}(\text{Denver}) = \text{Colorado}$.

Functions: Linear, Quadratic, and Exponential Models ★ (F-LE)

Cluster: *Construct and compare linear, quadratic, and exponential models and solve problems.*

Standard: F.LE.1 Distinguish between situations that can be modeled with linear functions and with exponential functions. (★)

- Prove that linear functions grow by equal differences over equal intervals, and that exponential functions grow by equal factors over equal intervals.
- Recognize situations in which one quantity changes at a constant rate per unit interval relative to another.
- Recognize situations in which a quantity grows or decays by a constant percent rate per unit interval relative to another.

Suggested Standards for Mathematical Practice (MP):

MP.3 Construct viable arguments and critique the reasoning of others.

MP.4 Model with mathematics.

MP.7 Look for and make use of structure.

MP.5 Use appropriate tools strategically.

MP.8 Look for and express regularity in repeated reasoning.

Connections: F.LE.1-4

While students in Grade 8 examine some nonlinear situations, most of the functions explored are linear. In high school, basic understanding of functions is expanded to include exponential and other polynomial functions and how they compare to the behaviors of linear functions.

Explanations and Examples: F.LE.1

Given a contextual situation, describe whether the situation in question has a linear pattern of change or an exponential pattern of change.

Show that linear functions change at the same rate over time and that exponential functions change by equal factors over time.

Describe situations where one quantity changes at a constant rate per unit interval as compared to another.

Describe situations where a quantity grows or decays at a constant percent rate per unit interval as compared to another.

Students may use graphing calculators or programs, spreadsheets, or computer algebra systems to model and compare linear and exponential functions.

Examples:

- A cell phone company has three plans. Graph the equation for each plan, and analyze the change as the number of minutes used increases. When is it beneficial to enroll in Plan 1? Plan 2? Plan 3?
 - \$59.95/month for 700 minutes and \$0.25 for each additional minute,
 - \$39.95/month for 400 minutes and \$0.15 for each additional minute, and
 - \$89.95/month for 1,400 minutes and \$0.05 for each additional minute.

Continued on next page

Explanations and Examples: F.LE.1

- A computer store sells about 200 computers at the price of \$1,000 per computer. For each \$50 increase in price, about ten fewer computers are sold. How much should the computer store charge per computer in order to maximize their profit?

Students can investigate functions and graphs modeling different situations involving simple and compound interest. Students can compare interest rates with different periods of compounding (monthly, daily) and compare them with the corresponding annual percentage rate. Spreadsheets and applets can be used to explore and model different interest rates and loan terms.

- A couple wants to buy a house in five years. They need to save a down payment of \$8,000. They deposit \$1,000 in a bank account earning 3.25% interest, compounded quarterly. How much will they need to save each month in order to meet their goal?
- Sketch and analyze the graphs of the following two situations. What information can you conclude about the types of growth each type of interest has?
 - Lee borrows \$9,000 from his mother to buy a car. His mom charges him 5% interest a year, but she does not compound the interest.
 - Lee borrows \$9,000 from a bank to buy a car. The bank charges 5% interest compounded annually.
- Calculate the future value of a given amount of money, with and without technology.
- Calculate the present value of a certain amount of money for a given length of time in the future, with and without technology.
- The data in the table was taken from Wikipedia.

- a. Based on the data in the table, would a linear function be appropriate to model the relationship between the world population and the year? Explain how you know.
- b. Using only the data from 1960 onward in the above table, would a linear function be appropriate to approximate the relationship between the world population and the year? Explain how you know.

Year	World Population (Estimate)
1804	1,000,000,000
1927	2,000,000,000
1960	3,000,000,000
1974	4,000,000,000
1987	5,000,000,000
1999	6,000,000,000
2012	7,000,000,000

- c. Based on your work in parts a. and b., would a linear function be appropriate to predict the world population in 2200? Explain.
- Carbon 14 is a common form of carbon which decays exponentially over time. The half-life of Carbon 14, that is the amount of time it takes for half of any amount of Carbon 14 to decay, is approximately 5730 years. Suppose we have a plant fossil and that the plant, at the time it died, contained 10 micrograms of Carbon 14 (one microgram is equal to one millionth of a gram).
 - a. Using this information, make a table to calculate how much Carbon 14 remains in the fossilized plant after $5730 \times n$ years for $n = 0, 1, 2, 3, 4$.
 - b. What can you conclude from part a. about when there is one microgram of Carbon 14 remaining in the fossil?
 - c. How much carbon remains in the fossilized plant after $2865 = \frac{5730}{2}$ years? Explain how you know.
 - d. Using the information from part c., can you give a more precise response to when there is one microgram of Carbon 14 remaining in the fossilized plant?

Continued on next page

Instructional Strategies: F.LE.1-4

Compare tabular representations of a variety of functions to show that linear functions have a first common difference (i.e., equal differences over equal intervals), while exponential functions do not (instead function values grow by equal factors over equal x -intervals).

Apply linear and exponential functions to real-world situations. For example, a person earning \$10 per hour experiences a constant rate of change in salary given the number of hours worked, while the number of bacteria on a dish that doubles every hour will have equal factors over equal intervals.

Provide examples of arithmetic and geometric sequences in graphic, verbal, or tabular forms, and have students generate formulas and equations that describe the patterns.

Use a graphing calculator or computer program to compare tabular and graphic representations of exponential and polynomial functions to show how the y (output) values of the exponential function eventually exceed those of polynomial functions.

Have students draw the graphs of exponential and other polynomial functions on a graphing calculator or computer utility and examine the fact that the exponential curve will eventually get higher than the polynomial function's graph. A simple example would be to compare the graphs (and tables) of the functions $y = x^2$ and $y = 2x$ to find that the y values are greater for the exponential function when $x > 4$.

Help students to see that solving an equation such as $2x = 300$ can be accomplished by entering $y = 22$ and $y = 300$ into a graphing calculator and finding where the graphs intersect, by viewing the table to see where the function values are about the same, as well as by applying a logarithmic function to both sides of the equation.

Explore simple linear and exponential functions by engaging in hands-on experiments. For example, students can measure the diameters and related circumferences of several circles and determine a linear function that relates the diameter to the circumference – a linear function with a first common difference. They can then explore the value of an investment when told that the account will double in value every 12 years – an exponential function with a base of 2

Common Misconceptions: F.LE.1-4

Students may believe that all functions have a first common difference and need to explore to realize that, for example, a quadratic function will have equal second common differences in a table.

Students may also believe that the end behavior of all functions depends on the situation and not the fact that exponential function values will eventually get larger than those of any other polynomial functions.

Functions: Linear, Quadratic, and Exponential Models ★ (F-LE)

Cluster: *Construct and compare linear, quadratic, and exponential models and solve problems.*

Standard: F.LE.2 Construct linear and exponential functions, including arithmetic and geometric sequences, given a graph, a description of a relationship, or two input-output pairs (include reading these from a table.) (★)

Suggested Standards for Mathematical Practice (MP):

MP.2 Reason abstractly and quantitatively. MP.8 Look for and express regularity in repeated reasoning.
MP.7 Look for and make use of structure.

Connections: See [F.LE.1](#)

Common Misconceptions: See [F.LE.1](#)

Explanations and Examples: F.LE.2

In constructing linear functions in F.LE.2 draw on and consolidate previous work in Grade 8 on finding equations for lines and linear functions. In 8th grade students work on identifying slope and unit rates for linear functions given two points, a table or a graph.

Students may use graphing calculators or programs, spreadsheets, or computer algebra systems to model and compare linear and exponential functions.

Examples:

- Determine an exponential function of the form $f(x) = ab^2$ using data points from the table. Graph the function and identify the key characteristics of the graph.

x	$f(x)$
0	1
1	3
3	27

- Sara's starting salary is \$32,500. Each year she receives a \$700 raise. Write a sequence in explicit form to describe the situation.
- Solve the equation $2^x = 300$.

Sample Response:

Using a graphing calculator enter $y = 2^x$ and $y + 300$. Find where the graphs intersect by viewing the table to see where the function values are about the same.

Continued on next page

Explanations and Examples: F.LE.2

- Albuquerque boasts one of the longest aerial trams in the world. The tram transports people up to Sandia Peak. The table shows the elevation of the tram at various times during a particular ride.

Minutes into the Ride	2	5	9	14
Elevation in Feet	7069	7834	8854	10,129

- Write an equation for a function (linear, quadratic, or exponential) that models the relationship between the elevation of the tram and the number of minutes into the ride. Justify your choice.
- What was the elevation of the tram at the beginning of the ride?
- If the ride took 15 minutes, what was the elevation of the tram at the end of the ride?

Solution:

- The average rate of change in height with respect to time between each column in the table is the same:

$$\frac{7834 - 7069}{5 - 2} = \frac{8854 - 7834}{9 - 5} = \frac{10129 - 8854}{14 - 9} = 255.$$

Therefore we choose a linear function to model the relationship. If y represents the elevation of the tram in feet and x represents the number of minutes into the trip, then $y - 7069 = 255(x - 2)$ for each pair (x, y) in the table, so the linear function given by $y = 7069 + 255(x - 2)$ works.

2. When $x = 0$ $y = 7069 + 255(0 - 2) = 6559.$

So, the elevation of the tram at the beginning of the ride is 6559 feet.

3. When $x = 15$ $y = 7069 + 255(15 - 2) = 10,384.$

So, the elevation of the tram at the end of the ride is 10,384 feet.

Instructional Strategies: See [F.LE.1](#)

Functions: Linear, Quadratic, and Exponential Models ★ (F-LE)

Cluster: *Construct and compare linear, quadratic, and exponential models and solve problems.*

Standard: F.LE.3 Observe using graphs and tables that a quantity increasing exponentially eventually exceeds a quantity increasing linearly, quadratically, or (more generally) as a polynomial function. (★)

Suggested Standards for Mathematical Practice (MP):

MP.2 Reason abstractly and quantitatively. MP.8 Look for and express regularity in repeated reasoning.

Connections: See [F.LE.1](#)

Common Misconceptions: See [F.LE.1](#)

Explanations and Examples: F.LE.3

Start F.LE.3 by limiting to comparisons between linear and exponential models, then compare linear and exponential growth to quadratic growth.

Examples:

- Contrast the growth of the $f(x) = x^3$ and $f(x) = 3^x$.
 - Mr. Wiggins gives his daughter Celia two choices of payment for raking leaves:
 - 1st Choice: Two dollars for *each* bag of leaves.
 - 2nd Choice: She will be paid for the number of bags of leaves she rakes as follows: two cents for one bag, four cents for two bags, eight cents for three bags, and so on with the amount doubling for each additional bag.
- a. If Celia rakes five bags of leaves, should she opt for payment method 1 or 2?
What if she rakes ten bags of leaves?
- b. How many bags of leaves does Celia have to rake before method 2 pays more than method 1?

Sample Responses:

A table of values giving the number of bags of leaves and the amount paid using methods 1 and 2 shows that method 1 pays more up to and including eleven bags.

b. The table also shows that method 2 pays more as soon as Celia rakes at least twelve bags of leaves. We know that method 2 will always pay more, beyond the twelfth bag, because doubling an amount x gives a larger increase than adding 2 as soon as x is greater than 2: $2x > x + 2$ whenever $x > 2$.

Number of Bags	Payment Method 1 (dollars)	Payment Method 2 (dollars)
1	2	0.02
2	4	0.04
3	6	0.08
4	8	0.16
5	10	0.32
6	12	0.64
7	14	1.28
8	16	2.56
9	18	5.12
10	20	10.24
11	22	20.48
12	24	40.96

Continued on next page

Explanations and Examples: F.LE.3*Sample Responses:*

The numbers in the second column of the table in the first solution form part of the arithmetic sequence which starts with 2 and increases each time by 2: the n^{th} term in this arithmetic sequence is $2n$ and this is the number in the n^{th} row of the second column of the table. The third column of the table is a geometric sequence which starts at 0.02 and increases by multiples of 2 each time. The n^{th} term in this sequence, found in the n^{th} row of the third column, is $2^n/100$.

The numerator 2^n shows the geometric sequence, while the denominator 100 reflects the fact that the sequence began at $2/100$.

Geometric sequences grow exponentially. Since the multiplier two is larger than one, the geometric sequence grows faster than, and eventually surpasses, the linear arithmetic sequence. To see this more clearly, note that each additional bag of leaves makes Celia two dollars with method 1 while with method 2 it doubles her payment. Hence as soon as payment method 2 is worth more than two dollars (that is after 8 bags of leaves) method 2 pays more than method 1 for every additional bag and so the deficit is quickly made up

Instructional Strategies: See [F.LE.1](#)

Functions: Linear, Quadratic, and Exponential Models ★ [\(F-LE\)](#)

Cluster: *Construct and compare linear, quadratic, and exponential models and solve problems.*

Standard: F.LE.4 For exponential models, express as a logarithm the solution to $ab^{ct} = d$ where a , c , and d are numbers and the base b is 2, 10, or e ; evaluate the logarithm using technology. (★)

Suggested Standards for Mathematical Practice (MP):

MP.4 Model with mathematics.

MP.7 Look for and make use of structure.

MP.5 Use appropriate tools strategically.

Connections: See [F.LE.1](#)

Common Misconceptions: See [F.LE.1](#)

Explanations and Examples: F.LE.4

Students may use graphing calculators or programs, spreadsheets, or computer algebra systems to analyze exponential models and evaluate logarithms.

Examples:

- Solve $200 e^{0.04t} = 450$ for t .

Solution:

First, isolate the exponential part by dividing both sides of the equation by 200.

$$e^{0.04t} = 2.25$$

Next, take the natural logarithm of both sides.

$$\ln e^{0.04t} = \ln 2.25$$

The left-hand side simplifies to $0.04t$ by logarithmic identity 1.

$$0.04t = \ln 2.25$$

Lastly, divide both sides by 0.04

$$t = \ln(2.25)/0.04$$

$$t \approx 20.3$$

Instructional Strategies: See [F.LE.1](#)

Functions: Linear, Quadratic, and Exponential Models ★ (F-LE)

Cluster: *Interpret expressions for functions in terms of the situation they model.*

Standard: F.LE.5 Interpret the parameters in a linear or exponential function in terms of a context. (★)

Suggested Standards for Mathematical Practice (MP):

MP.2 Reason abstractly and quantitatively.

MP.4 Model with mathematics.

Connections:

Understanding slope as a rate of change, as well as working with integral exponents, are important elements of the Grade 8 curriculum. In high school, knowledge is extended into a thorough study of functions that includes a contextual understanding of parameter changes in both linear and exponential function situations.

Explanations and Examples: F.LE.5

Limit exponential functions to those of the form $f(x) = b^x + k$.

Students may use graphing calculators or programs, spreadsheets, or computer algebra systems to model and interpret parameters in linear, quadratic or exponential functions.

Examples:

- A function of the form $f(n) = P(1 + r)^n$ is used to model the amount of money in a savings account that earns 5% interest, compounded annually, where n is the number of years since the initial deposit. What is the value of r ? What is the meaning of the constant P in terms of the savings account? Explain either orally or in written format.
- The total cost for a plumber who charges \$50 for a house call and \$85 per hour would be expressed as the function $y = 85x + 50$. If the rate were raised to \$90 per hour, how would the function change?
- The equation $y = 8,000(1.04)^x$ models the rising population of a city with 8,000 residents when the annual growth rate is 4%.
 - What would be the effect on the equation if the city's population were 12,000 instead of 8,000?
 - What would happen to the population over 25 years if the growth rate were 6% instead of 4%?

Continued on next page

Explanations and Examples: F.LE.5

- Lauren keeps records of the distances she travels in a taxi and what she pays:

Distance (d) in miles	Fare (F) in dollars
3	8.25
5	12.75
11	26.25

- If you graph the ordered pairs (d, F) from the table, they lie on a line. How can you tell this without graphing them?
- Show that the linear function in part a. has equation $F = 2.25d + 1.5$.
- What do the 2.25 and the 1.5 in the equation represent in terms of taxi rides?

Solution:

a. The slope of the line segment connecting $(3, 8.25)$ and $(5, 12.75)$ is $\frac{(12.75-8.25)}{(5-3)} = 2.25$.
The slope of the line segment connecting $(5, 12.75)$ and $(11, 26.25)$ is $\frac{(26.25-12.75)}{(11-5)} = 2.25$. Because the two line segments are connected and have the same slope, the three points lie on the same line.

b. There is only one possible line in part (a), since two points determine a line. The graph of $F = 2.25d + 1.5$ is a line, so if we show that each ordered pair satisfies it then we will know that it is the same line as in part (a).

$$\begin{aligned}(3, 8.25) : 2.25(3) + 1.5 &= 8.25 \\ (5, 12.75) : 2.25(5) + 1.5 &= 12.75 \\ (11, 26.25) : 2.25(11) + 1.5 &= 26.25\end{aligned}$$

c. The 2.25 represents the cost per mile for the ride. The 1.5 represents a fixed cost for every ride; it does not depend on the distance traveled.

Instructional Strategies: F.LE.5

Use real-world contexts to help students understand how the parameters of linear and exponential functions depend on the context. For example, a plumber who charges \$50 for a house call and \$85 per hour would be expressed as the function $y = 85x + 50$, and if the rate were raised to \$90 per hour, the function would become $y = 90x + 50$. On the other hand, an equation of $y = 8,000(1.04)^x$ could model the rising population of a city with 8,000 residents when the annual growth rate is 4%. Students can examine what would happen to the population over 25 years if the rate were 6% instead of 4% or the effect on the equation and function of the city's population were 12,000 instead of 8,000.

Graphs and tables can be used to examine the behaviors of functions as parameters are changed, including the comparison of two functions such as what would happen to a population if it grew by 500 people per year, versus rising an average of 8% per year over the course of 10 years.

Provide students with opportunities to research raw data on the Internet (such as increases in gasoline consumption in China over the years) and to graph and generalize trends in growth, determining whether the growth is linear.

Students can be given different parameters of a function to manipulate and compare the results to draw conclusions about the effects of the changes.

Common Misconceptions: F.LE.5

Students may believe that changing the slope of a linear function from "2" to "3" makes the graph steeper without realizing that there is a real-world context and reason for examining the slopes of lines. Similarly, an exponential function can appear to be abstract until applying it to a real-world situation.

Functions: Trigonometric Functions (F-TF)

Cluster: *Extend the domain of trigonometric functions using the unit circle.*

Standard: F.TF.1 Understand radian measure of an angle as the length of the arc on the unit circle subtended by the angle.

Suggested Standards for Mathematical Practice (MP):

MP.6 Attend to precision.

Connections: F.TF.1-2

The study of trigonometry is reserved for high school students. In the Geometry conceptual category, students explore right triangle trigonometry, with advanced students working with laws of sines and cosines. In the conceptual category of Functions, students connect the idea of functions with trigonometry and see sine, cosine and tangent values as functions of angle values input in radians. Connections are made such as the cosine of an angle equaling the sine of its complement as well as to the Geometry Standards involving radian measures.

Explanations and Examples: F.TF.1

Know that if the length of an arc subtended by an angle is the same length as the radius of the circle, then the measure of the angle is 1 radian.

Know that the graph of the function, f , is the graph of the equation $y = f(x)$.

Examples:

- What is the radian measure of the angle t in the diagram below?

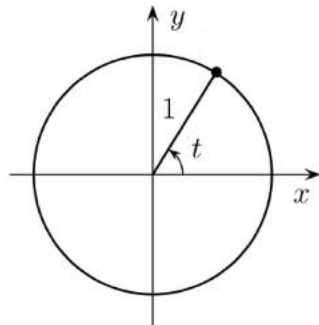

- The minute hand on the clock at the City Hall clock in Stratford measures 2.2 meters from the tip to the axle.
 - a. Through what angle does the minute hand pass between 7:07 a.m. and 7:43 a.m.?
 - b. What distance does the tip of the minute hand travel during this period?

Continued on next page

Instructional Strategies: F.TF.1-2

Use a compass and straightedge to explore a unit circle with a fixed radius of 1. Help students to recognize that the circumference of the circle is 2π , which represents the number of radians for one complete revolution around the circle. Students can determine that, for example, $\pi/4$ radians would represent a revolution of $1/8$ of the circle or 45° .

Having a circle of radius 1, the cosine, for example, is simply the x -value for any ordered pair on the circle (adjacent/hypotenuse where adjacent is the x -length and hypotenuse is 1). Students can examine how a counterclockwise rotation determines a coordinate of a particular point in the unit circle from which sine, cosine, and tangent can be determined.

Common Misconceptions: F.TF.1-2

Students may believe that there is no need for radians if one already knows how to use degrees. Students need to be shown a rationale for how radians are unique in terms of finding function values in trigonometry since the radius of the unit circle is 1.

Students may also believe that all angles having the same reference values have identical sine, cosine and tangent values. They will need to explore in which quadrants these values are positive and negative.

Functions: Trigonometric Functions (F-TF)

Cluster: *Extend the domain of trigonometric functions using the unit circle.*

Standard: F.TF.2 Explain how the unit circle in the coordinate plane enables the extension of trigonometric functions to all real numbers, interpreted as radian measures of angles traversed counterclockwise around the unit circle.

Suggested Standards for Mathematical Practice (MP):

MP.2 Reason abstractly and quantitatively. MP.6 Attend to precision.
MP.3 Construct viable arguments and critique the reasoning of others.

Connections: See [F.TF.1](#)

Common Misconceptions: See [F.TF.1](#)

Explanations and Examples: F.TF.2

Students may use applets and animations to explore the unit circle and trigonometric functions. Students may explain their understanding orally or in written form.

Examples:

- Using the Unit Circle, find the following:

$\sin(-30^\circ) =$	$\tan 420^\circ =$	$\cos(-90^\circ) =$	$\csc\left(\frac{\pi}{3}\right) =$	$\cot(-45^\circ) =$
$\sin 330^\circ =$	$\tan 60^\circ =$	$\cos 270^\circ =$	$\csc\left(\frac{13\pi}{3}\right) =$	$\cot(-765^\circ) =$

$\sec\left(\frac{16\pi}{3}\right) =$	$\csc\left(\frac{9\pi}{4}\right) =$	$\tan(4\pi) =$	$\sin\left(\frac{3\pi}{2}\right) =$	$\cos\left(\frac{-\pi}{6}\right) =$
$\sec\left(\frac{4\pi}{3}\right) =$	$\csc\left(\frac{\pi}{4}\right) =$	$\tan(10\pi) =$	$\sin\left(\frac{11\pi}{2}\right) =$	$\cos\left(\frac{11\pi}{6}\right) =$

- Look at each pair of angles above. What do you notice about those pairs?
- What conclusions can you draw about the trigonometric functions and how they work about the circle?

Instructional Strategies: F.TF.1-2

Use a compass and straightedge to explore a unit circle with a fixed radius of 1. Help students to recognize that the circumference of the circle is 2π , which represents the number of radians for one complete revolution around the circle. Students can determine that, for example, $\pi/4$ radians would represent a revolution of $1/8$ of the circle or 45° .

Having a circle of radius 1, the cosine, for example, is simply the x -value for any ordered pair on the circle (adjacent/hypotenuse where adjacent is the x -length and hypotenuse is 1). Students can examine how a counterclockwise rotation determines a coordinate of a particular point in the unit circle from which sine, cosine, and tangent can be determined.

Functions: Trigonometric Functions (F-TF)

Cluster: *Model periodic phenomena with trigonometric functions.*

Standard: F.TF.5 Choose trigonometric functions to model periodic phenomena with specified amplitude, frequency, and midline. (★)

Suggested Standards for Mathematical Practice (MP):

MP.4 Model with mathematics.

MP.7 Look for and make use of structure.

MP.5 Use appropriate tools strategically.

Connections:

The study of trigonometry is reserved for high school students. In the Geometry conceptual category, students explore right triangle trigonometry. In the conceptual category of Functions, students connect the idea of functions with trigonometry and explore the effects of parameter changes on the amplitude, frequency and midline of trigonometric graphs.

Explanations and Examples: F.TF.5

Define amplitude, frequency, and midline of a trigonometric function.

Explain the connection between frequency and period.

Use sine and cosine to model periodic phenomena such as the ocean's tide or the rotation of a Ferris wheel.

Given the amplitude; frequency; and midline in situations or graphs, determine a trigonometric function used to model the situation.

Write a function notation for the trigonometric function that models a problem situation.

Examples:

- The temperature of a chemical reaction oscillates between a low of 20°C and a high of 120°C . The temperature is at its lowest point when $t = 0$ and completes one cycle over a 6-hour period.
 - a. Sketch the temperature, T , against the elapsed time, t , over a 12-hour period.
 - b. Find the period, amplitude, and the midline of the graph you drew in part a.
 - c. Write a function to represent the relationship between time and temperature.
 - d. What will the temperature of the reaction be 14 hours after it began?
 - e. At what point during a 24-hour day will the reaction have a temperature of 60°C ?

- A wheel of radius 0.2 meters begins to move along a flat surface so that the center of the wheel moves forward at a constant speed of 2.4 meters per second. At the moment the wheel begins to turn a marked point P on the wheel is touching the flat surface.

Write an algebraic expression for the function y that gives the height (in meters) of the point P , measured from the flat surface, as a function of t , the number of seconds after the wheel begins moving.

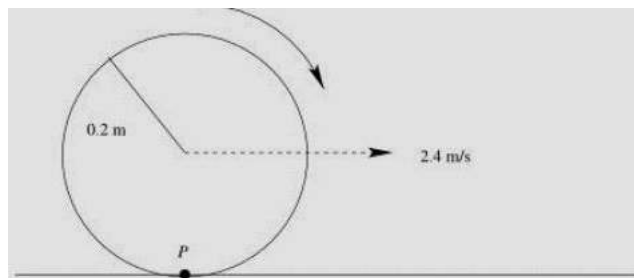

Continued on next page

Instructional Strategies: F.TF.5

Allow students to explore real-world examples of periodic functions. Examples include average high (or low) temperatures throughout the year, the height of ocean tides as they advance and recede, and the fractional part of the moon that one can see on each day of the month. Graphing some real-world examples can allow students to express the amplitude, frequency, and midline of each.

Help students to understand what the value of the sine (cosine, or tangent) means (e.g., that the number represents the ratio of two sides of a right triangle having that angle measure).

Using graphing calculators or computer software, as well as graphing simple examples by hand, have students graph a variety of trigonometric functions in which the amplitude, frequency, and/or midline is changed. Students should be able to generalize about parameter changes, such as what happens to the graph of $y = \cos(x)$ when the equation is changed to $y = 3\cos(x) + 5$.

Common Misconceptions: F.TF.5

Students may believe that all trigonometric functions have a range of 1 to -1. Students need to see examples of how coefficients can change the range and the look of the graphs.

Functions: Trigonometric Functions (F-TF)

Cluster: *Prove and apply trigonometric identities.*

Standard: F.TF.8 Prove the Pythagorean identity $\sin^2(\theta) + \cos^2(\theta) = 1$ and use it to find $\sin(\theta)$, $\cos(\theta)$, or $\tan(\theta)$ given $\sin(\theta)$, $\cos(\theta)$, or $\tan(\theta)$ and the quadrant of the angle.

Suggested Standards for Mathematical Practice (MP):

MP.3 Construct viable arguments and critique the reasoning of others.

MP.7 Look for and make use of structure. MP.8 Look for and express regularity in repeated reasoning.

Connections:

Students in Grade 8 grade learn to use the Pythagorean Theorem, while high school students in a geometry unit (or course) develop right triangle trigonometry. This cluster allows high school students to connect these ideas as they derive a Pythagorean relationship for the trigonometric functions.

Explanations and Examples: F.TF.8

Use the unit circle to prove the Pythagorean identity $\sin^2(\theta) + \cos^2(\theta) = 1$.

Given the value of the $\sin(\theta)$ or $\cos(\theta)$, use the Pythagorean identity $\sin^2(\theta) + \cos^2(\theta) = 1$ to calculate other trigonometric ratios.

Examples:

- Proving $\sin^2 \theta + \cos^2 \theta = 1$
- Given the Unit Circle below, complete the following steps:
 - Identify the center of the circle (the origin) as O
 - Label point P on the unit circle in Quadrant I
 - Draw ray \overrightarrow{OP} as the terminal ray of angle θ
 - Draw \overline{PR} which is a line segment perpendicular to the x-axis
- What is the length of \overrightarrow{OP} ? Justify your answer.
- What is the length of \overline{PR} ? Justify your answer.
- What is the length of \overline{OR} ? Justify your answer.
- Using the Pythagorean Theorem, justify the Identity $\sin^2 \theta + \cos^2 \theta = 1$.

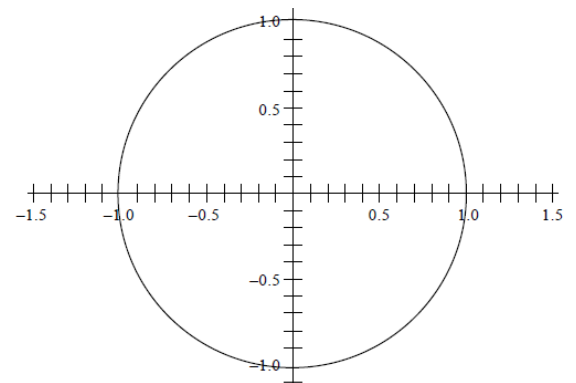

Continued on next page

Explanations and Examples: F.TF.8

- Given that $\cos \theta = \frac{\sqrt{3}}{2}$ and $\frac{3\pi}{2} < \theta < 2\pi$ find the values of $\sin(\theta)$ and $\tan(\theta)$.

Instructional Strategies: F.TF.8

In the unit circle, the cosine is the x -value, while the sine is the y -value. Since the hypotenuse is always 1, the Pythagorean relationship $\sin^2(\theta) + \cos^2(\theta) = 1$ is always true. Students can make a connection between the Pythagorean Theorem in geometry and the study of trigonometry by proving this relationship. In turn, the relationship can be used to find the cosine when the sine is known, and vice-versa. Provide a context in which students can practice and apply skills of simplifying radicals.

Common Misconceptions: F.TF.8

Students may believe that there is no connection between the Pythagorean Theorem and the study of trigonometry.

Students may also believe that there is no relationship between the sine and cosine values for a particular angle. The fact that the sum of the squares of these values always equals 1 provides a unique way to view trigonometry through the lens of geometry.

Conceptual Category Geometry

An understanding of the attributes and relationships of geometric objects can be applied in diverse contexts—interpreting a schematic drawing, estimating the amount of wood needed to frame a sloping roof, rendering computer graphics, or designing a sewing pattern for the most efficient use of material.

Although there are many types of geometry, school mathematics is devoted primarily to plane Euclidean geometry, studied both synthetically (without coordinates) and analytically (with coordinates). Euclidean geometry is characterized most importantly by the Parallel Postulate that through a point not on a given line there is exactly one parallel line. (Spherical geometry, in contrast, has no parallel lines.)

During high school, students begin to formalize their geometry experiences from elementary and middle school, using more precise definitions and developing careful proofs. Later in college some students develop Euclidean and other geometries carefully from a small set of axioms.

The concepts of congruence, similarity, and symmetry can be understood from the perspective of geometric transformation. Fundamental are the rigid motions: translations, rotations, reflections, and combinations of these, all of which are here assumed to preserve distance and angles (and therefore shapes generally). Reflections and rotations each explain a particular type of symmetry, and the symmetries of an object offer insight into its attributes—as when the reflective symmetry of an isosceles triangle assures that its base angles are congruent.

In the approach taken here, two geometric figures are defined to be congruent if there is a sequence of rigid motions that carries one onto the other. This is the principle of superposition. For triangles, congruence means the equality of all corresponding pairs of sides and all corresponding pairs of angles. During the middle grades, through experiences drawing triangles from given conditions, students notice ways to specify enough measures in a triangle to ensure that all triangles drawn with those measures are congruent. Once these triangle congruence criteria (ASA, SAS, and SSS) are established using rigid motions, they can be used to prove theorems about triangles, quadrilaterals, and other geometric figures.

Similarity transformations (rigid motions followed by dilations) define similarity in the same way that rigid motions define congruence, thereby formalizing the similarity ideas of “same shape” and “scale factor” developed in the middle grades. These transformations lead to the criterion for triangle similarity that two pairs of corresponding angles are congruent.

The definitions of sine, cosine, and tangent for acute angles are founded on right triangles and similarity, and, with the Pythagorean Theorem, are fundamental in many real-world and theoretical situations. The Pythagorean Theorem is generalized to non-right triangles by the Law of Cosines. Together, the Laws of Sines and Cosines embody the triangle congruence criteria for the cases where three pieces of information suffice to completely solve a triangle. Furthermore, these laws yield two possible solutions in the ambiguous case, illustrating that Side-Side-Angle is not a congruence criterion.

Analytic geometry connects algebra and geometry, resulting in powerful methods of analysis and problem solving. Just as the number line associates numbers with locations in one dimension, a pair of perpendicular axes associates pairs of numbers with locations in two dimensions. This correspondence between numerical coordinates and geometric points allows methods from algebra to be applied to geometry and vice versa. The solution set of an equation becomes a geometric curve, making visualization a tool for doing and understanding algebra. Geometric shapes can be described by equations, making algebraic manipulation into a tool for geometric understanding, modeling, and proof. Geometric transformations of the graphs of equations correspond to algebraic changes in their equations.

Dynamic geometry environments provide students with experimental and modeling tools that allow them to investigate geometric phenomena in much the same way as computer algebra systems allow them to experiment with algebraic phenomena.

Connections to Equations. The correspondence between numerical coordinates and geometric points allows methods from algebra to be applied to geometry and vice versa. The solution set of an equation becomes a geometric curve, making visualization a tool for doing and understanding algebra. Geometric shapes can be described by equations, making algebraic manipulation into a tool for geometric understanding, modeling, and proof.

Geometry Standards Overview

Note: The standards identified with a (+) contain additional mathematics that students should learn in order to take advanced courses such as calculus, advanced statistics or discrete mathematics that go beyond the mathematics that all students should study in order to be college- and career-ready. Explanations and examples of these standards are not included in this document.

Modeling Standards: *Specific modeling standards appear throughout the high school standards indicated by a star symbol (★).*

[\(RETURN TO PG. 5\)](#)

Congruence (G-CO)

- *Experiment with transformations in the plane.*
[G.CO.1](#) [G.CO.2](#) [G.CO.3](#) [G.CO.4](#) [G.CO.5](#)
- *Understand congruence in terms of rigid motions.*
[G.CO.6](#) [G.CO.7](#) [G.CO.8](#)
- *Prove geometric theorems.*
[G.CO.9](#) [G.CO.10](#) [G.CO.11](#)
- *Make geometric constructions.*
[G.CO.12](#) [G.CO.13](#)

Similarity, Right Triangles, and Trigonometry (G-SRT)

- *Understand similarity in terms of similarity transformations.*
[G.SRT.1](#) [G.SRT.2](#) [G.SRT.3](#)
- *Prove theorems involving similarity.*
[G.SRT.4](#) [G.SRT.5](#)
- *Define trigonometric ratios and solve problems involving right triangles.*
[G.SRT.6](#) [G.SRT.7](#) [G.SRT.8](#) (★)
- *Apply trigonometry to general triangles.*
G.SRT.9 (+) G.SRT.10 (+) G.SRT.11 (+)

Circles (G-C)

- *Understand and apply theorems about circles.*
[G.C.1](#) [G.C.2](#) [G.C.3](#) G.C.4 (+)
- *Find arc lengths and areas of sectors of circles.*
[G.C.5](#)

Expressing Geometric Properties with Equations (G-GPE)

- *Translate between the geometric description and the equation for a conic section.*
[G.GPE.1](#) [G.GPE.2](#) G.GPE.3 (+)
- *Use coordinates to prove simple geometric theorems algebraically.*
[G.GPE.4](#) [G.GPE.5](#) [G.GPE.6](#) [G.GPE.7](#) (★)

Geometric Measurement and Dimensions (G-GMD)

- *Explain volume formulas and use them to solve problems.*
[G.GMD.1](#) G.GMD.2 (+) [G.GMD.3](#) (★)
- *Visualize relationships between two-dimensional and three-dimensional objects.*
[G.GMD.4](#)

Modeling with Geometry (G-MG) (★)

- *Apply geometric concepts in modeling situations.*
[G.MG.1](#) (★) [G.MG.2](#) (★) [G.MG.3](#) (★)

Geometry: Congruence [\(G-CO\)](#)

Cluster: *Experiment with transformations in the plane.*

Standard: G.CO.1 Know precise definitions of angle, circle, perpendicular line, parallel line, and line segment, based on the undefined notions of point, line, distance along a line, and distance around a circular arc.

Suggested Standards for Mathematical Practice (MP):

MP.6 Attend to precision.

Connections: G.CO.1-5

Rotations, reflections and translations are developed experimentally in the Grade 8, and this experience should be built upon in high school, giving greater attention to precise definitions and formal reasoning.

Transformations can be studied in terms of functions, where the inputs and outputs are points in the plane, rather than numbers.

Rotations are studied again in the cluster about circles.

Explanations and Examples: G.CO.1

Understand and use definitions of angles, circles, perpendicular lines, parallel lines, and line segments based on the undefined term of a point, a line, the distance along a line, and the length of an arc.

Define angles, circles, perpendicular lines, rays, and line segments precisely using the undefined terms and “if-then” and “if-only-if” statements.

Examples:

- Have students write their own understanding of a given term.
- Give students formal and informal definitions of each term and compare them.
- Develop precise definitions through use of examples and non-examples.
- Discuss the importance of having precise definitions.

Instructional Strategies: G.CO.1-5

Review vocabulary associated with transformations (e.g. point, line, segment, angle, circle, polygon, parallelogram, perpendicular, rotation reflection, translation).

Provide both individual and small-group activities, allowing adequate time for students to explore and verify conjectures about transformations and develop precise definitions of rotations, reflections and translations.

Provide real-world examples of rigid motions (e.g. Ferris wheels for rotation; mirrors for reflection; moving vehicles for translation).

Use graph paper, transparencies, tracing paper or dynamic geometry software to obtain images of a given figure under specified transformations.

Continued on next page

Instructional Strategies: G.CO.1-5

Provide students with a pre-image and a final, transformed image, and ask them to describe the steps required to generate the final image. Show examples with more than one answer (e.g., a reflection might result in the same image as a translation).

Work backwards to determine a sequence of transformations that will carry (map) one figure onto another of the same size and shape.

Focus attention on the attributes (e.g. distances or angle measures) of a geometric figure that remain constant under various transformations.

Make the transition from transformations as physical motions to functions that take points in the plane as inputs and give other points as outputs. The correspondence between the initial and final points determines the transformation.

Analyze various figures (e.g. regular polygons, folk art designs or product logos) to determine which rotations and reflections carry (map) the figure onto itself. These transformations are the “symmetries” of the figure.

Emphasize the importance of understanding a transformation as the correspondence between initial and final points, rather than the physical motion.

Use a variety of means to represent rigid motions, including physical manipulatives, coordinate methods, and dynamic geometry software.

Common Misconceptions: G.CO.1-5

The terms “mapping” and “under” are used in special ways when studying transformations. A translation is a type of transformation that moves all the points in the object in a straight line in the same direction.

Students should know that not every transformation is a translation.

Students sometimes confuse the terms “transformation” and “translation.”

Geometry: Congruence [\(G-CO\)](#)

Cluster: *Experiment with transformations in the plane.*

Standard: G.CO.2 Represent transformations in the plane using, e.g., transparencies and geometry software; describe transformations as functions that take points in the plane as inputs and give other points as outputs. Compare transformations that preserve distance and angle to those that do not (e.g., translation versus horizontal stretch).

Suggested Standards for Mathematical Practice (MP):

MP.5 Use appropriate tools strategically.

MP.6 Attend to precision.

Connections:

Rotations, reflections and translations are developed experimentally in the Grade 8, and this experience should be built upon in high school, giving greater attention to precise definitions and formal reasoning.

Transformations can be studied in terms of functions, where the inputs and outputs are points in the plane, rather than numbers.

Rotations are studied again in the cluster about circles.

Explanations and Examples: G.CO.2

In middle school students have worked with translations, reflections, and rotations and informally with dilations. Point out the basis of rigid motions in geometric concepts, e.g., translations move points a specified distance along a line parallel to a specified line; rotations move objects along a circular arc with a specified center through a specified angle.

Use various technologies such as transparencies, geometry software, interactive whiteboards, and digital visual presenters to represent and compare rigid and size transformations of figures in a coordinate plane. Comparing transformations that preserve distance and angle to those that do not.

Describe and compare function transformations on a set of points as inputs to produce another set of points as outputs, to include translations and horizontal and vertical stretching.

Students may use geometry software and/or manipulatives to model and compare transformations.

Examples:

- Draw transformations of reflections, rotations, translations, and combinations of these using graph paper, transparencies and/or geometry software.
- Determine the coordinates for the image (output) of a figure when a transformation rule is applied to the preimage (input).
- Distinguish between transformations that are rigid (preserve distance and angle measure-reflections, rotations, translations, or combinations of these) and those that are not (dilations or rigid motions followed by dilations).

Continued on next page

Explanations and Examples: G.CO.2

- The figure below is reflected across the y -axis and then shifted up by 4 units. Draw the transformed figure and label the new coordinates.

What function can be used to describe these transformations in the coordinate plane?

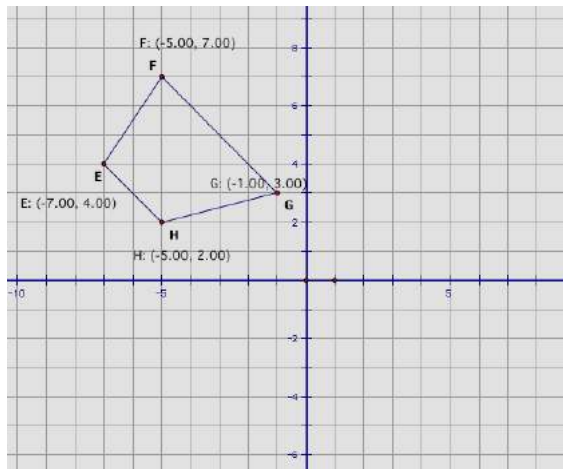

Solution:
 $(-1x, y + 4)$

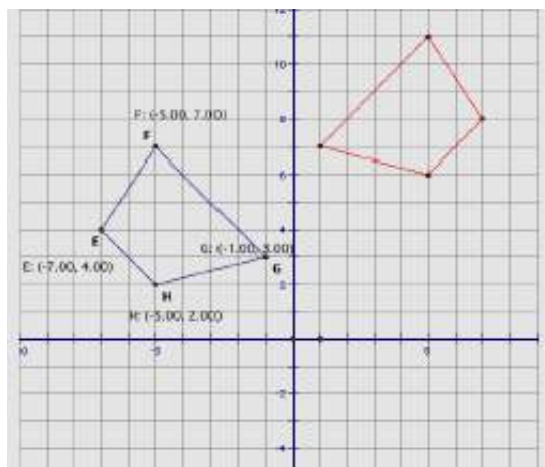

Instructional Strategies: G.CO.1-5

Provide both individual and small-group activities, allowing adequate time for students to explore and verify conjectures about transformations and develop precise definitions of rotations, reflections and translations.

Provide real-world examples of rigid motions (e.g. Ferris wheels for rotation; mirrors for reflection; moving vehicles for translation).

Use graph paper, transparencies, tracing paper or dynamic geometry software to obtain images of a given figure under specified transformations.

Provide students with a pre-image and a final, transformed image, and ask them to describe the steps required to generate the final image. Show examples with more than one answer (e.g., a reflection might result in the same image as a translation).

Work backwards to determine a sequence of transformations that will carry (map) one figure onto another of the same size and shape.

Focus attention on the attributes (e.g. distances or angle measures) of a geometric figure that remain constant under various transformations.

Make the transition from transformations as physical motions to functions that take points in the plane as inputs and give other points as outputs. The correspondence between the initial and final points determines the transformation.

Analyze various figures (e.g. regular polygons, folk art designs or product logos) to determine which rotations and reflections carry (map) the figure onto itself. These transformations are the “symmetries” of the figure.

Emphasize the importance of understanding a transformation as the correspondence between initial and final points, rather than the physical motion.

Use a variety of means to represent rigid motions, including physical manipulatives, coordinate methods, and dynamic geometry software.

Common Misconceptions: G.CO.1-5

The terms “mapping” and “under” are used in special ways when studying transformations. A translation is a type of transformation that moves all the points in the object in a straight line in the same direction.

Students should know that not every transformation is a translation. Students sometimes confuse the terms “transformation” and “translation.”

Geometry: Congruence [\(G-CO\)](#)

Cluster: *Experiment with transformations in the plane.*

Standard: G.CO.3 Given a rectangle, parallelogram, trapezoid, or regular polygon, describe the rotations and reflections that carry it onto itself.

Suggested Standards for Mathematical Practice (MP):

MP.3 Construct viable arguments and critique the reasoning of others.

MP.5 Use appropriate tools strategically.

MP.7 Look for and make use of structure.

Connections: See [G.CO.1](#)

Common Misconceptions: See [G.CO.1](#)

Explanations and Examples: G.CO.3

Describe and illustrate how a rectangle, parallelogram, and isosceles trapezoid are mapped onto themselves using transformations.

Calculate the number of lines of reflection symmetry and the degree of rotational symmetry of any regular polygon. Students may use geometry software and/or manipulatives to model transformations.

Examples:

1. Draw the shaded triangle after:
 - a. It has been translated -7 horizontally and $+1$ vertically. Label your answer A .
 - b. It has been reflected over the x -axis. Label your answer B .
 - c. It has been rotated 90° clockwise around the origin. Label your answer C .
 - d. It has been reflected over the line $y = x$. Label your answer D .
2. Describe fully the single transformation that:
 - a. Takes the shaded triangle onto the triangle labeled E .
 - b. Takes the shaded triangle onto the triangle labeled F .

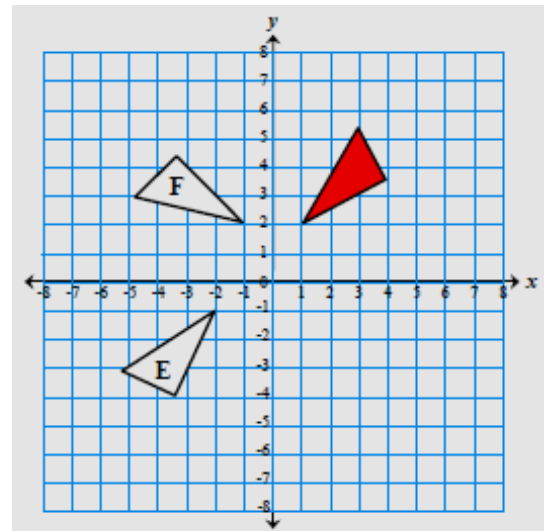

- For each of the following shapes, describe the rotations and reflections that carry it onto itself.

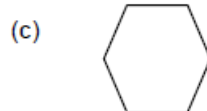

Instructional Strategies: See [G.CO.1](#)

Geometry: Congruence ([G-CO](#))

Cluster: *Experiment with transformations in the plane.*

Standard: G.CO.4 Develop definitions of rotations, reflections, and translations in terms of angles, circles, perpendicular lines, parallel lines, and line segments.

Suggested Standards for Mathematical Practice (MP):

MP.5 Use appropriate tools strategically.

MP.6 Attend to precision.

MP.7 Look for and make use of structure.

Connections: See [G.CO.1](#)

Common Misconceptions: See [G.CO.1](#)

Explanations and Examples: G.CO.4

Using previous comparisons and descriptions of transformations develop and understand the meaning of rotations, reflections, and translations based on angles, circles, perpendicular lines, parallel lines, and line segments.

Students may use geometry software and/or manipulatives to model transformations. Students may observe patterns and develop definitions of rotations, reflections, and translations.

Examples:

- Perform a rotation, reflection, and translation with a given polygon and give a written explanation of how each step meets the definitions of each transformation using correct mathematical terms.
- Construct the reflection definition by connecting any point on the preimage to its corresponding point on the reflected image and describe the line segment's relationship to the line of reflection (e.g., the line of reflection is the perpendicular bisector of the segment).
- Construct the translation definition by connecting any point on the preimage to its corresponding point on the translated image, and connect a second point on the preimage to its corresponding point on the translated image, and describe how the two segments are equal in length, point in the same direction, and are parallel.
- Construct the rotation definition by connecting the center of rotation to any point on the preimage and to its corresponding point on the rotated image, and describe the measure of the angle formed and the equal measures of the segments that formed the angle as part of the definition.

Instructional Strategies: See [G.CO.1](#)

Geometry: Congruence [\(G-CO\)](#)

Cluster: *Experiment with transformations in the plane.*

Standard: G.CO.5 Given a geometric figure and a rotation, reflection, or translation, draw the transformed figure using, e.g., graph paper, tracing paper, or geometry software. Specify a sequence of transformations that will carry a given figure onto another.

Suggested Standards for Mathematical Practice (MP):

MP.3 Construct viable arguments and critique the reasoning of others.

MP.5 Use appropriate tools strategically.

MP.7 Look for and make use of structure.

Connections: See [G.CO.1](#)

Common Misconceptions: See [G.CO.1](#)

Explanations and Examples: G.CO.5

Transform a geometric figure given a rotation, reflection, or translation using graph paper, tracing paper, or geometric software.

Create sequences of transformations that map a geometric figure on to itself and another geometric figure. Draw a specific transformation when given a geometric figure and a rotation, reflection or translation.

Predict and verify the sequence of transformations (a composition) that will map a figure onto another.

Students may use geometry software and/or manipulatives to model transformations and demonstrate a sequence of transformations that will carry a given figure onto another.

Examples:

- The triangle in the upper left of the figure below has been reflected across a line into the triangle in the lower right of the figure. Use a straightedge and compass to construct the line across which the triangle was reflected

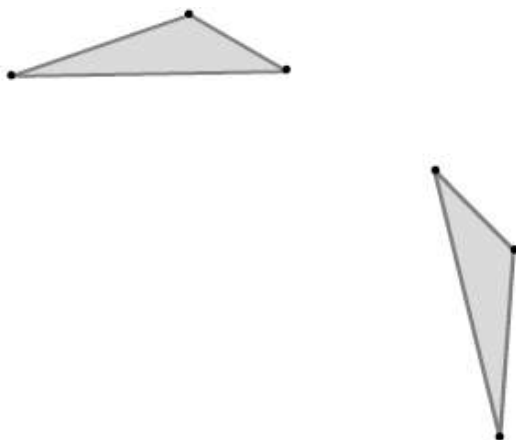

Continued on next page

Explanations and Examples: G.CO.5

- For the diagram below, describe the sequence of transformations that was used to carry $\triangle JKL$ (Image 1) onto Image 2.

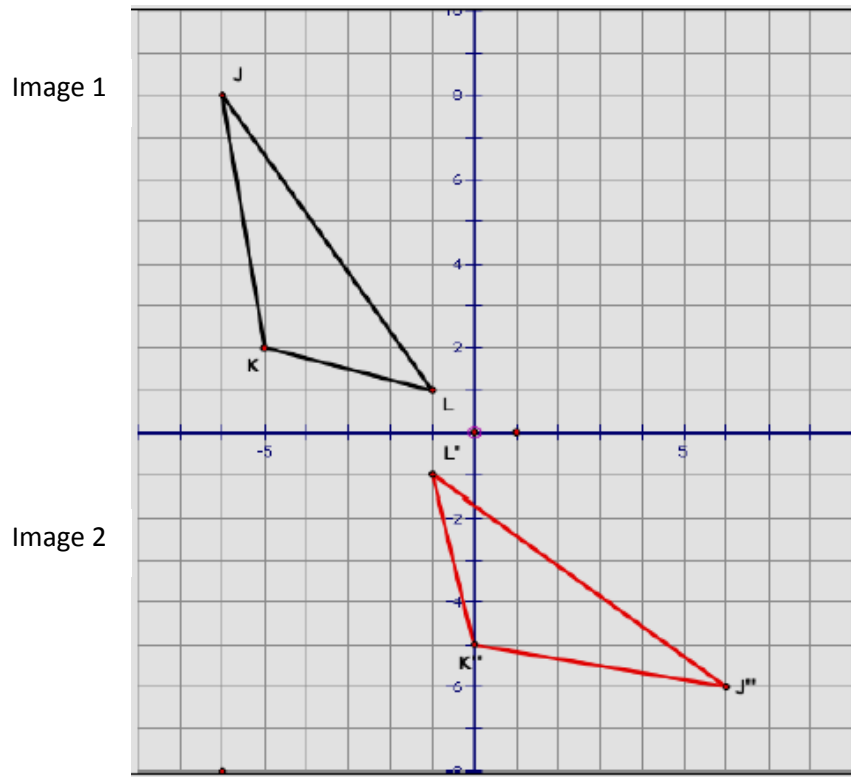

Instructional Strategies: See [G.CO.1](#)

Geometry: Congruence (G-CO)

Cluster: *Understand congruence in terms of rigid motion.*

Standard: G.CO.6 Use geometric descriptions of rigid motions to transform figures and to predict the effect of a given rigid motion on a given figure; given two figures, use the definition of congruence in terms of rigid motions to decide if they are congruent.

Suggested Standards for Mathematical Practice (MP):

MP.3 Construct viable arguments and critique the reasoning of others.

MP.5 Use appropriate tools strategically.

MP.7 Look for and make use of structure.

Connections: G.CO.6-8

An understanding of congruence using physical models, transparencies or geometry software is developed in Grade 8, and should be built upon in high school with greater attention to precise definitions, careful statements and proofs of theorems and formal reasoning.

Explanations and Examples: G.CO.6

For standards G.CO.6-8 the focus is for students to understand that rigid motions are at the foundation of the definition of congruence. Students reason from the basic properties of rigid motions (that they preserve distance and angle), which are assumed without proof. Rigid motions and their assumed properties can be used to establish the usual triangle congruence criteria, which can then be used to prove other theorems.

Use descriptions of rigid motion and transformed geometric figures to predict the effects rigid motion has on figures in the coordinate plane.

Knowing that rigid transformations preserve size and shape or distance and angle, use this fact to connect the idea of congruency and develop the definition of congruent. Determine if two figures are congruent by determining if rigid motions will turn one figure into the other.

Examples:

- $\triangle ABC$ has vertices $A(-1, 0)$, $B(4, 0)$, $C(2, 6)$
 - a. Draw $\triangle ABC$ on the coordinate grid provided.
 - b. Translate $\triangle ABC$ using the rule $(x, y) \rightarrow (x - 6, y - 5)$ to create $\triangle A'B'C'$. Record the new coordinate grid (using a different color if possible).
 A' _____ B' _____ C' _____
 - c. Rotate $\triangle A'B'C'$ 90° CCW using the rule $(x, y) \rightarrow$ _____ to create $\triangle A''B''C''$. Record the new coordinates below and add the triangle to your coordinate grid (using a different color if possible).
 A'' _____ B'' _____ C'' _____
 - d. Write ONE rule below that would change $\triangle ABC$ to $\triangle A''B''C''$ in one step.

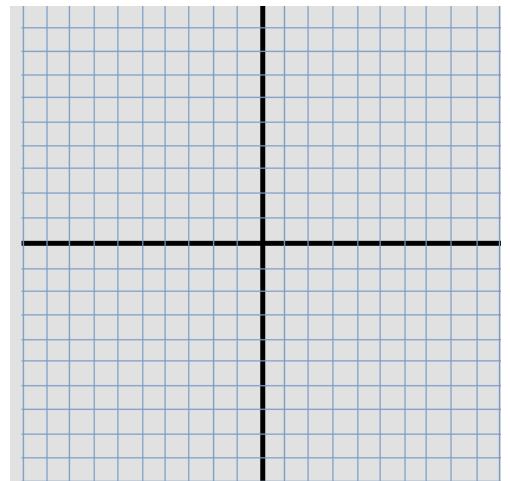

Continued on next page

Explanations and Examples: G.CO.6

- Determine if the figures below are congruent. If so tell what rigid motions were used.

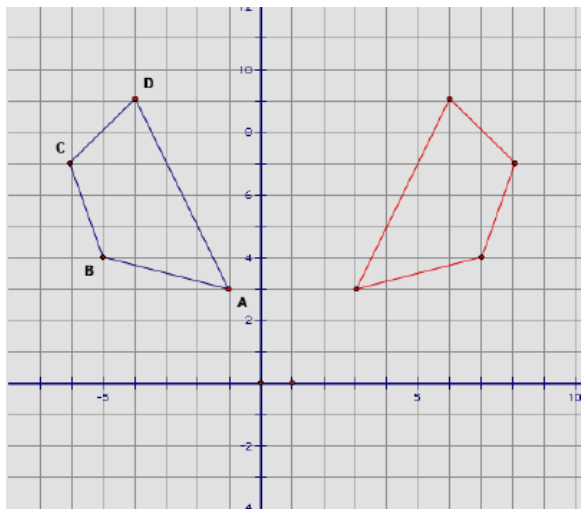

Instructional Strategies: G.CO.6-8

Develop the relationship between transformations and congruency. Allow adequate time and provide hands-on activities for students to visually and physically explore rigid motions and congruence.

Use graph paper, tracing paper or dynamic geometry software to obtain images of a given figure under specified rigid motions. Note that size and shape are preserved.

Use rigid motions (translations, reflections and rotations) to determine if two figures are congruent. Compare a given triangle and its image to verify that corresponding sides and corresponding angles are congruent.

Work backwards – given two figures that have the same size and shape, find a sequence of rigid motions that will map one onto the other.

Build on previous learning of transformations and congruency to develop a formal criterion for proving the congruency of triangles. Construct pairs of triangles that satisfy the ASA, SAS or SSS congruence criteria, and use rigid motions to verify that they satisfy the definition of congruent figures. Investigate rigid motions and congruence both algebraically (using coordinates) and logically (using proofs).

Common Misconceptions: G.CO.6-8

Some students may believe:

That combinations such as SSA or AAA are also a congruence criterion for triangles. Provide counterexamples for this misconception.

That all transformations, including dilations, are rigid motions. Provide counterexamples for this misconception.

That any two figures that have the same area represent a rigid transformation. Students should recognize that the areas remain the same, but preservation of side and angle lengths determine that the transformation is rigid.

That corresponding vertices do not have to be listed in order; however, it is useful to stress the importance of listing corresponding vertices in the same order so that corresponding sides and angles can be easily identified and that included sides or angles are apparent.

Geometry: Congruence ([G-CO](#))

Cluster: *Understand congruence in terms of rigid motion.*

Standard: G.CO.7 Use the definition of congruence in terms of rigid motions to show that two triangles are congruent if and only if corresponding pairs of sides and corresponding pairs of angles are congruent.

Suggested Standards for Mathematical Practice (MP):

MP.3 Construct viable arguments and critique the reasoning of others.

Connections: See [G.CO.6](#)

Explanations and Examples: G.CO.7

A rigid motion is a transformation of points in space consisting of a sequence of one or more translations, reflections, and/or rotations. Rigid motions are assumed to preserve distances and angle measures. Two triangles are said to be congruent if one can be exactly superimposed on the other by a rigid motion, and the congruence theorems specify the conditions under which this can occur.

Students identify corresponding sides and corresponding angles of congruent triangles of congruent triangles.

Explain that in a pair of congruent triangles, corresponding sides are congruent (distance is preserved) and corresponding angles are congruent (angles measure is preserved).

Demonstrate that when distance is preserved (corresponding sides are congruent) and angle measure is preserved (corresponding angles are congruent) the triangles must also be congruent.

Examples:

- How many ways can you construct a triangle congruent to the given triangle inside the rectangle? Demonstrate each.

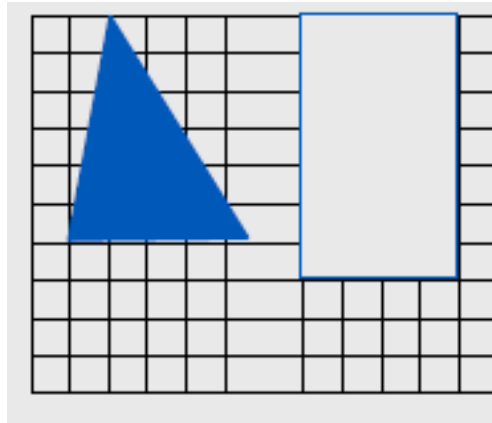

Continued on next page

Explanations and Examples: G.CO.7

- Are the following triangles congruent? Explain how you know.

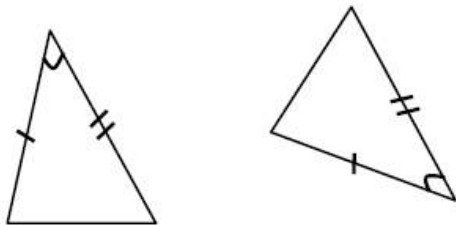

Instructional Strategies: G.CO.6-8

Develop the relationship between transformations and congruency. Allow adequate time and provide hands-on activities for students to visually and physically explore rigid motions and congruence.

Use graph paper, tracing paper or dynamic geometry software to obtain images of a given figure under specified rigid motions. Note that size and shape are preserved.

Use rigid motions (translations, reflections and rotations) to determine if two figures are congruent. Compare a given triangle and its image to verify that corresponding sides and corresponding angles are congruent.

Work backwards – given two figures that have the same size and shape, find a sequence of rigid motions that will map one onto the other.

Build on previous learning of transformations and congruency to develop a formal criterion for proving the congruency of triangles. Construct pairs of triangles that satisfy the ASA, SAS or SSS congruence criteria, and use rigid motions to verify that they satisfy the definition of congruent figures. Investigate rigid motions and congruence both algebraically (using coordinates) and logically (using proofs).

Common Misconceptions: G.CO.6-8

Some students may believe:

That combinations such as SSA or AAA are also a congruence criterion for triangles. Provide counterexamples for this misconception.

That all transformations, including dilations, are rigid motions. Provide counterexamples for this misconception.

That any two figures that have the same area represent a rigid transformation. Students should recognize that the areas remain the same, but preservation of side and angle lengths determine that the transformation is rigid.

That corresponding vertices do not have to be listed in order; however, it is useful to stress the importance of listing corresponding vertices in the same order so that corresponding sides and angles can be easily identified and that included sides or angles are apparent.

Geometry: Congruence ([G-CO](#))

Cluster: *Understand congruence in terms of rigid motion.*

Standard: G.CO.8 Explain how the criteria for triangle congruence (ASA, SAS, and SSS) follow from the definition of congruence in terms of rigid motions.

Suggested Standards for Mathematical Practice (MP):

MP.2 Reason abstractly and quantitatively.

MP.3 Construct viable arguments and critique the reasoning of others.

Connections: See [G.CO.6](#)

Common Misconceptions: See [G.CO.6](#)

Explanations and Examples: G.CO.8

List the sufficient conditions to prove triangles are congruent.

Map a triangle with one of the sufficient conditions (e.g., SSS) onto the original triangle and show that corresponding sides and corresponding angles are congruent.

Examples:

- Josh is told that two triangles ABC and DEF share two sets of congruent sides and one pair of congruent angles: AB is congruent to DE , BC is congruent to EF , and angle C is congruent to angle F . He is asked if these two triangles must be congruent. Josh draws the two triangles below and says, "They are definitely congruent because they share all three side lengths!"
 - Explain Josh's reasoning using one of the triangle congruence criteria: ASA, SSS, SAS.
 - Give an example of two triangles ABC and DEF , fitting the criteria of this problem, which are **not** congruent.

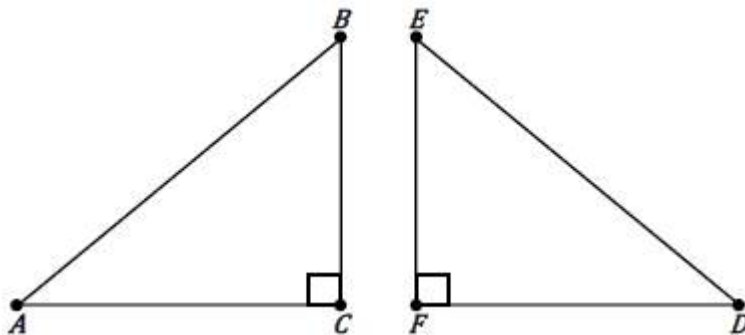

Continued on next page

Explanations and Examples: G.CO.8

Sample Response:

- a. Josh's reasoning is incorrect because he has made the unwarranted assumption that angles C and F are right angles. However, with that additional assumption his statement is correct, since we may apply the Pythagorean theorem to conclude that $|AC|^2 = |AB|^2 - |BC|^2$ and $|DF|^2 = |DE|^2 - |EF|^2$.

Since DE is congruent to AB and EF is congruent to BC by hypothesis we can conclude that AC must be congruent to DF and so, by SSS, triangle ABC is congruent to triangle DEF . Instead of SSS, we could also apply SAS using right angles C and F along with sides AC and BC for triangle ABC and sides DF and EF for triangle DEF.

- b. The information given amounts to SSA, two congruent sides and a congruent angle which is *not* the angle determined by the two sets of congruent sides. This is a lot of information and, as might be expected, does not leave much ambiguity. Consider five points A, B, C, D, E as pictured below with isosceles triangle ADE :

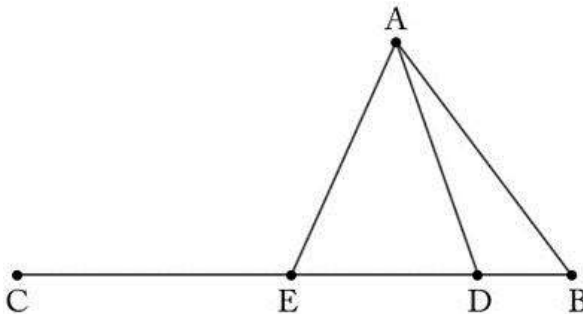

Triangles ABD and ABE share angle B and side AB while AD is congruent to AE by construction. The triangles ABD and ABE are definitely not congruent, however, as one of them is properly contained within the other.

The given information heavily restricted this construction but we were still able to find two non congruent triangles sharing two congruent sides and a non-included congruent angle.

- Decide whether there is enough information to prove that the two shaded triangles are congruent. In the figure below, $ABCD$ is a parallelogram.

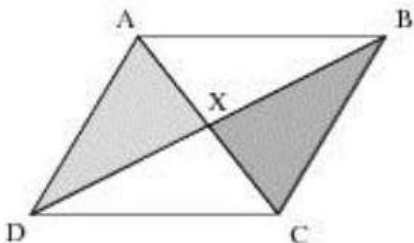

Solution: The two triangles are congruent by SAS.

We have $AX \cong CX$ and $DX \cong BX$ since the diagonals of a parallelogram bisect each other and $\angle AXD \cong \angle BXC$ since they are vertical angles. Alternatively, we could use and argue via ASA. We have the opposite interior angles $\angle DAX \cong \angle BCX$ and $\angle ADX \cong \angle CBX$ and $AD \cong BC$ since opposite sides of a parallelogram are congruent.

Instructional Strategies: See [G.CO.6](#)

Build on previous learning of transformations and congruency to develop a formal criterion for proving the congruency of triangles. Construct pairs of triangles that satisfy the ASA, SAS or SSS congruence criteria, and use rigid motions to verify that they satisfy the definition of congruent figures. Investigate rigid motions and congruence both algebraically (using coordinates) and logically (using proofs).

Geometry: Congruence (G-CO)

Cluster: *Prove geometric theorems.*

Standard: G.CO.9 Prove theorems about lines and angles. *Theorems include: vertical angles are congruent; when a transversal crosses parallel lines, alternate interior angles are congruent and corresponding angles are congruent; points on a perpendicular bisector of a line segment are exactly those equidistant from the segment's endpoints.*

Suggested Standards for Mathematical Practice (MP):

MP.2 Reason abstractly and quantitatively.

MP.5 Use appropriate tools strategically.

MP.3 Construct viable arguments and critique the reasoning of others.

Connections: G.CO.9-11

Properties of lines and angles, triangles and parallelograms were investigated in Grades 7 and 8. In high school, these properties are revisited in a more formal setting, giving greater attention to precise statements of theorems and establishing these theorems by means of formal reasoning.

The theorem about the midline of a triangle can easily be connected to a unit on similarity. The proof of it is usually based on the similarity property that corresponding sides of similar triangles are proportional.

Explanations and Examples: G.CO.9

Identify and use the properties of congruence and equality (reflexive, symmetric, transitive) in proofs.

Order statements based on the Law of Syllogism when constructing a proof.

Interpret geometric diagrams by identifying what can and cannot be assumed.

Students may use geometric simulations (computer software or graphing calculator) to explore theorems about lines and angles.

Examples:

- The diagram below depicts the construction of a parallel line, above the ruler. The steps in the construction result in a line through the given point that is parallel to the given line. Which statement below justifies why the constructed line is parallel to the given line?

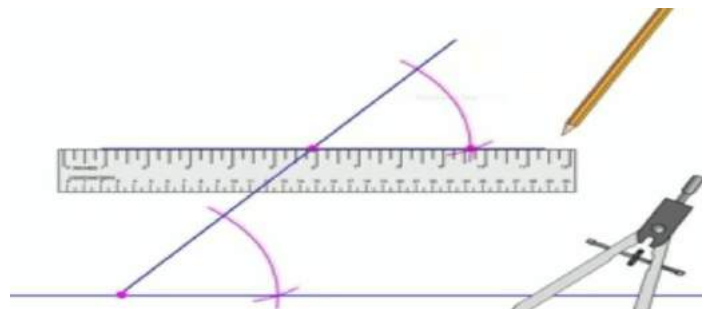

- When two lines are each perpendicular to a third line, the lines are parallel.
 - When two lines are each parallel to a third line, the lines are parallel.
 - When two lines are intersected by a transversal and alternate interior angles are congruent, the lines are parallel.
 - When two lines are intersected by a transversal and corresponding angles are congruent, the lines are parallel.
- (Correct answer d.)

Continued on next page

Explanations and Examples: G.CO.9

- Prove that $\angle HIB \cong \angle DJG$, given that $\overline{AB} \parallel \overline{DE}$.

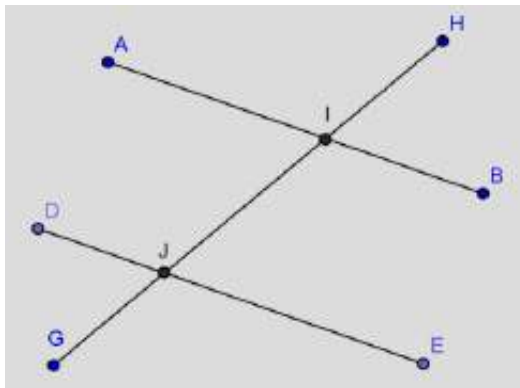

Instructional Strategies: G.CO.9-11

Encourage multiple ways of writing proofs, such as in narrative paragraphs, using flow diagrams, in two-column format, and using diagrams without words. Students should be encouraged to focus on the validity of the underlying reasoning while exploring a variety of formats for expressing that reasoning. Implementation of G.CO.10 may be extended to include concurrence of perpendicular bisectors and angle bisectors as preparation for G.C.3.

Classroom teachers and mathematics education researchers agree that students have a hard time learning how to do geometric proofs. An article by Battista and Clements (1995) (http://investigations.terc.edu/library/bookpapers/geometryand_proof.cfm) provides information for teachers to help students who struggle learn to do proof. The most significant implication for instructional strategies for proof is stated in their conclusion.

“Ironically, the most effective path to engendering meaningful use of proof in secondary school geometry is to avoid formal proof for much of students’ work. By focusing instead on justifying ideas while helping students build the visual and empirical foundation for higher levels of geometric thought, we can lead students to appreciate the need for formal proof. Only then will we be able to use it meaningfully as a mechanism for justifying ideas.”

The article and ideas from Niven (1987) offers a few suggestions about teaching proof in geometry:

- Initial geometric understandings and ideas should be taught “without excessive emphasis on rigor.” Develop basic geometric ideas outside an axiomatic framework, and then let the importance of the framework (and the framework itself) emerges from the geometry.
- Geometry is visual and should be taught in ways that leverage this aspect. Sketching, drawing and constructing figures and relationships between geometric objects should be central to any geometric study and certainly to proof. Battista and Clement make a powerful argument that the use of dynamic geometry software can be an important tool for helping students understand proof.
- “Avoid the deadly elaboration of the obvious” (Niven, p. 43). Often textbooks begin the treatment of formal proof with “easy” proofs, which appear to students to need no proof at all. After presenting many opportunities for students to “justify” properties of geometric figures, formal proof activities should begin with non-obvious conjectures.
- Use the history of geometry and real-world applications to help students develop conceptual understandings before they begin to use formal proof.

Continued on next page

Instructional Strategies: G.CO.9-11

Proofs in high school geometry should not be restricted to the two-column format. Most proofs at the college level are done in paragraph form, with the writer explaining and defending a conjecture. In many cases, the two-column format can hinder the student from making sense of the geometry by paying too much attention to format rather than mathematical reasoning.

Some of the theorems listed in this cluster (e.g. the ones about alternate interior angles and the angle sum of a triangle) are logically equivalent to the Euclidean parallel postulate, and this should be acknowledged.

Use dynamic geometry software to allow students to make conjectures that can, in turn, be formally proven. For example, students might notice that the base angles of an isosceles triangle always appear to be congruent when manipulating triangles on the computer screen and could then engage in a more formal discussion of why this occurs.

Common Core Standards Appendix A states, “Encourage multiple ways of writing proofs, such as in narrative paragraphs, using flow diagrams, in two-column format, and using diagrams without words.

Students should be encouraged to focus on the validity of the underlying reasoning while exploring a variety of formats for expressing that reasoning” (p. 29). Different methods of proof will appeal to different learning styles in the classroom.

Common Misconceptions: G.CO.9-11

Research over the last four decades suggests that student misconceptions about proof abound:

- even after proving a generalization, students believe that exceptions to the generalization might exist;
- one counterexample is not sufficient;
- the converse of a statement is true (parallel lines do not intersect, lines that do not intersect are parallel); and
- a conjecture is true because it worked in all examples that were explored.

Each of these misconceptions needs to be addressed, both by the ways in which formal proof is taught in geometry and how ideas about “justification” are developed throughout a student’s mathematical education.

Geometry: Congruence [\(G-CO\)](#)

Cluster: *Prove geometric theorems.*

Standard: G.CO.10 Prove theorems about triangles. *Theorems include: measures of interior angles of a triangle sum to 180° ; base angles of isosceles triangles are congruent; the segment joining midpoints of two sides of a triangle is parallel to the third side and half the length; the medians of a triangle meet at a point.*

Suggested Standards for Mathematical Practice (MP):

MP.2 Reason abstractly and quantitatively.

MP.5 Use appropriate tools strategically.

MP.3 Construct viable arguments and critique the reasoning of others.

Connections: See [G.CO.9](#)

Common Misconceptions: See [G.CO.9](#)

Explanations and Examples: G.CO.10

Order statements based on the Law of Syllogism when constructing a proof.

Interpret geometric diagrams by identifying what can and cannot be assumed.

Students may use geometric simulations (computer software or graphing calculator) to explore theorems about triangles.

Examples:

- For items 1 and 2, what additional information is required in order to prove the two triangles are congruent using the provided justification?

Use the set of choices in the box below. Select a side or angle and place it in the appropriate region. Only one side or angle can be placed in each region.

\overline{AB}	\overline{AC}	\overline{AD}	\overline{BC}
\overline{BD}	\overline{CD}	\overline{CE}	\overline{DE}
$\angle ABC$	$\angle ABD$	$\angle ACB$	$\angle ADB$
$\angle BAC$	$\angle CDE$	$\angle CED$	$\angle DCE$

Item 1

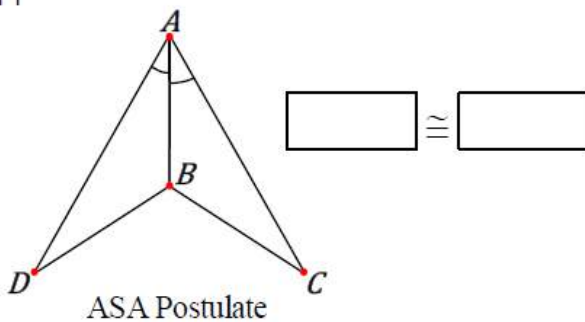

Key: Item 1 – $\angle ABD \cong \angle ABC$

Item 2

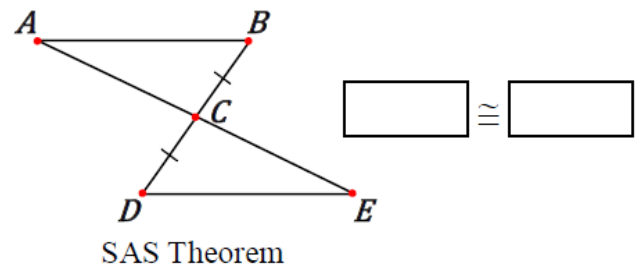

Item 2 – $AC \cong CE$

Continued on next page

Explanations and Examples: G.CO.10

- Given that $\triangle ABC$ is isosceles, prove that $\angle ABC \cong \angle ACB$.

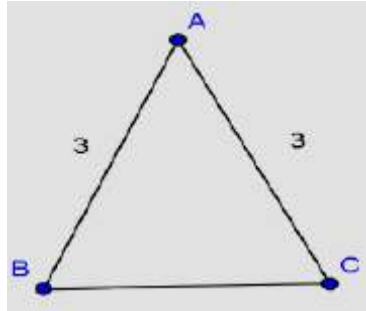

Instructional Strategies: See [G.CO.9](#)

Geometry: Congruence [\(G-CO\)](#)

Cluster: *Prove geometric theorems.*

Standard: G.CO.11 Prove theorems about parallelograms. *Theorems include: opposite sides are congruent, opposite angles are congruent, the diagonals of a parallelogram bisect each other, and conversely, rectangles are parallelograms with congruent diagonals.*

Suggested Standards for Mathematical Practice (MP):

MP.2 Reason abstractly and quantitatively.

MP.5 Use appropriate tools strategically.

MP.3 Construct viable arguments and critique the reasoning of others.

Connections: See [G.CO.9](#)

Common Misconceptions: See [G.CO.9](#)

Explanations and Examples: G.CO.11

Students may use geometric simulations (computer software or graphing calculator) to explore theorems about parallelograms.

Examples:

- Suppose that $ABCD$ is a parallelogram, and that M and N are the midpoints of \overline{AB} and \overline{CD} , respectively. Prove that $MN = AD$, and that the line \overleftrightarrow{MN} is parallel to \overleftrightarrow{AD} .

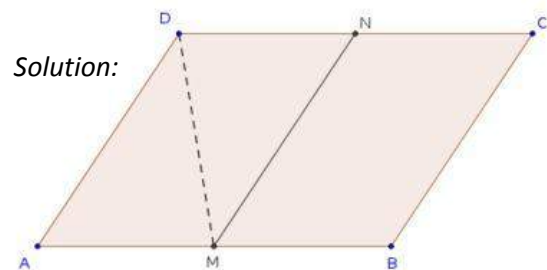
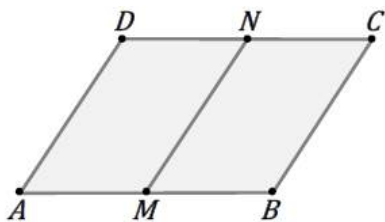

Solution:

The diagram above consists of the given information, and one additional line segment, \overline{MD} , which we will use to demonstrate the result. We claim that triangles $\triangle AMD$ and $\triangle NDM$ are congruent by SAS:

We have $\overline{MD} = \overline{DM}$ by reflexivity.

We have $\angle AMD = \angle NDM$ since they are opposite interior angles of the transversal MD through parallel lines AB and CD .

We have $\overline{MA} = \overline{ND}$, since M and N are midpoints of their respective sides, and opposite sides of parallelograms are congruent $\overline{MA} = \frac{1}{2}(\overline{AB}) = \frac{1}{2}(\overline{CD}) = \overline{ND}$

Now since corresponding parts of congruent triangles are congruent, we have $DA = NM$, as desired. Similarly, we have congruent opposite interior angles $\angle DMN \cong \angle MDA$, so \overleftrightarrow{MN} is parallel to \overleftrightarrow{AD} .

Instructional Strategies: See [G.CO.9](#)

Geometry: Congruence ([G-CO](#))

Cluster: *Make geometric constructions. (Formalize and explain processes.)*

Standard: G.CO.12 Make formal geometric constructions with a variety of tools and methods (compass and straightedge, string, reflective devices, paper folding, dynamic geometric software, etc.). *Copying a segment; copying an angle; bisecting a segment; bisecting an angle; constructing perpendicular lines, including the perpendicular bisector of a line segment; and constructing a line parallel to a given line through a point not on the line.*

Suggested Standards for Mathematical Practice (MP):

MP.5 Use appropriate tools strategically.

MP.6 Attend to precision.

Connections: G.CO.12-13

Drawing geometric shapes with rulers, protractors and technology is developed in Grade 7. In high school, students perform formal geometry constructions using a variety of tools. Students will utilize proofs to justify validity of their constructions.

Explanations and Examples: G.CO.12

For standards G.CO.12-13, the expectation is to build on prior student experience with simple constructions. Emphasize the ability to formalize and explain how these constructions result in the desired objects. Some of these constructions are closely related to previous standards and can be introduced with them.

Students may use geometric software to make geometric constructions.

Examples:

- Construct a triangle given the lengths of two sides and the measure of the angle between the two sides.
- Construct the circumcenter of a given triangle.
- Construct the perpendicular bisector of a line segment.

This construction can also be used to construct a 90 degree angle or to find the midpoint of a line.

1. Mark two points on your line, A and B - this construction will give you a straight line which passes exactly half way between these two points and is perpendicular (at right angles) to the line.
2. Open your compasses to a distance more than half way between A and B.
3. With the point of the compass on one of the points, draw circular arcs above and below the line, at P and Q.
4. Keeping the compasses set to exactly the same distance, repeat with the compass point on your other point.
5. Draw a line through the P and Q.
6. PQ is the perpendicular bisector of AB - check that the angles are exactly 90 degrees and that it does indeed halve the distance between A and B.

<http://motivate.maths.org/content/accurate-constructions>

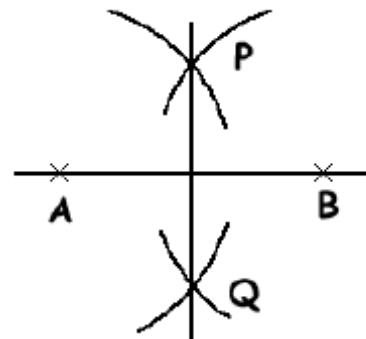

Continued on next page

Explanations and Examples: G.CO.12

- You have been asked to place a warehouse so that it is an equal distance from the three roads indicated on the following map. Find this location and show your work.

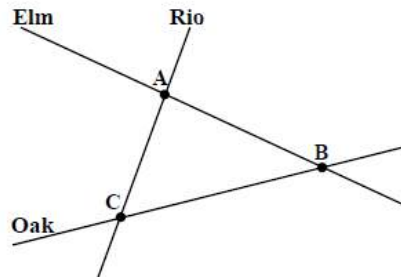

- Show how to fold your paper to physically construct this point as an intersection of two creases.
- Explain why the above construction works and, in particular, why you only needed to make two creases,

Solution: (This task connects to standard G.C.3)

- Fold and crease the paper so that Oak lies on top of Rio. Do the same so that Oak lies on top of Elm. The point of intersection of the two creases is the point an equal distance from the three sides.
- Since the desired location should be an equal distance from three sides of triangle ABC, we are looking for the center of the circle inscribed in the triangle. The center of the inscribed circle, called the incenter, can be found by constructing the angle bisectors of the three interior angles of the triangle, as in the diagram below. Since these angle bisectors are concurrent, it is sufficient to construct two of the angle bisectors (and hence only make two creases in part (a)).

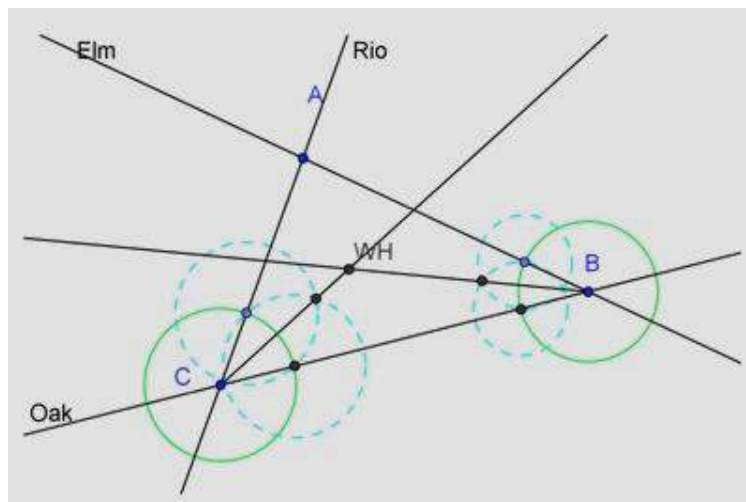

Now we show the concurrence of the three angle bisectors: It is easy to see that the distance from the warehouse $W = WH$ to Rio equals the distance from W to Oak. Namely, draw perpendiculars from W to both Rio and Oak, with respective intersection points X and Y .

The triangles $\triangle WXC$ and $\triangle WYC$ are congruent since they are right triangles with $\angle WCX = \angle WCY$ and sharing side WC . So $WX = WY$. Similarly, drawing a perpendicular to Elm through W meeting Elm at Z , we have $WY = WZ$. Combining the two equalities, we learn that $WX = WZ$, so that W is on the angle bisector and the three angle bisectors are concurrent.

Continued on next page

Instructional Strategies: G.CO.12-13

Students should analyze each listed construction in terms of what simpler constructions are involved (e.g., constructing parallel lines can be done with two different constructions of perpendicular lines).

Using congruence theorems, ask students to prove that the constructions are correct.

Provide meaningful problems (e.g. constructing the centroid or the incenter of a triangle) to offer students practice in executing basic constructions.

Challenge students to perform the same construction using a compass and string. Use paper folding to produce a reflection; use bisections to produce reflections.

Ask students to write “how-to” manuals, giving verbal instructions for a particular construction. Offer opportunities for hands-on practice using various construction tools and methods.

Compare dynamic geometry commands to sequences of compass-and-straightedge steps. Prove, using congruence theorems, that the constructions are correct.

Common Misconceptions: G.CO.12-13

Some students may believe that a construction is the same as a sketch or drawing. Emphasize the need for precision and accuracy when doing constructions. Stress the idea that a compass and straightedge are identical to a protractor and ruler. Explain the difference between measurement and construction.

Geometry: Congruence [\(G-CO\)](#)

Cluster: *Make geometric constructions. (Formalize and explain processes.)*

Standard: G.CO.13 Construct an equilateral triangle, a square, and a regular hexagon inscribed in a circle.

Suggested Standards for Mathematical Practice (MP):

MP.5 Use appropriate tools strategically.

MP.6 Attend to precision.

Connections: See [G.CO.12](#)

Common Misconceptions: See [G.CO.12](#)

Explanations and Examples: G.CO.13

For standards G.CO.12-13, the expectation is to build on prior student experience with simple constructions. Emphasize the ability to formalize and explain how these constructions result in the desired objects. Some of these constructions are closely related to previous standards and can be introduced with them.

Students may use geometric software to make geometric constructions.

Examples:

- Construct a regular hexagon inscribed in a circle.

This construction can also be used to draw a 120° angle.

Keep your compasses to the same setting throughout this construction.

Draw a circle.

Mark a point, P, on the circle.

Put the point of your compasses on P and draw arcs to cut the circle at Q and U.

Put the point of your compasses on Q and draw an arc to cut the circle at R.

Repeat with the point of the compasses at R and S to draw arcs at S and T.

Join PQRSTU to form a regular hexagon.

Measure the lengths to check they are all equal, and the angles to check they are all 120° .

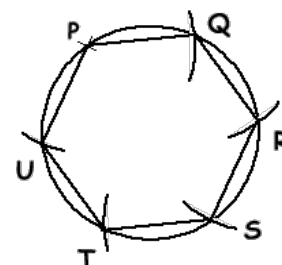

- Find two ways to construct a hexagon inscribed in a circle as shown.

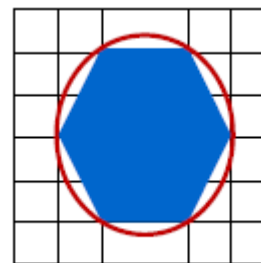

Instructional Strategies: See [G.CO.12](#)

Geometry: Similarity, Right Triangles, and Trigonometry [\(G-SRT\)](#)

Cluster: *Understand similarity in terms of similarity transformations.*

Standard: G.SRT.1 Verify experimentally the properties of dilations given by a center and a scale factor:

- A dilation takes a line not passing through the center of the dilation to a parallel line, and leaves a line passing through the center unchanged.
- The dilation of a line segment is longer or shorter in the ratio given by the scale factor.

Suggested Standards for Mathematical Practice (MP):

MP.2 Reason abstractly and quantitatively.

MP.6 Attend to precision.

MP.5 Use appropriate tools strategically.

MP.8 Look for and express regularity in repeated reasoning.

Connections: G.SRT.1-3

Dilations and similarity, including the AA criterion, are investigated in Grade 8, and these experiences should be built upon in high school with greater attention to precise definitions, careful statements and proofs of theorems and formal reasoning.

Explanations and Examples: G.SRT.1

Students should understand that a dilation is a transformation that moves each point along the ray through the point emanating from a fixed center, and multiplies distances from the center by a common scale factor. Perform a dilation with a given center and scale factor on a figure in the coordinate plane. Verify that when a side passes through the center of dilation, the side and its image lie on the same line. Verify that corresponding sides of the preimage and images are parallel. Verify that a side length of the image is equal to the scale factor multiplied by the corresponding side length of the preimage.

Students may use geometric simulation software to model transformations. Students may observe patterns and verify experimentally the properties of dilations.

Examples:

- Suppose we apply a dilation by a factor of 2, centered at the point P to the figure below.

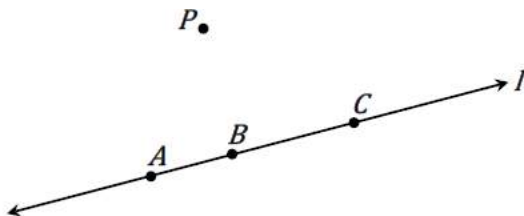

- In the picture, locate the images A' , B' , and C' of the points A , B , C under this dilation.
- Based on your picture in part a., what do you think happens to the line l when we perform the dilation?
- Based on your picture in part a., what appears to be the relationship between the distance $A'B'$ and the distance AB ?
- Can you prove your observations in part c?

Continued on next page

Explanations and Examples: G.SRT.1

- Draw a polygon. Pick a point and construct a dilation of the polygon with that point as the center. Identify the scale factor that you used.

Example Response:

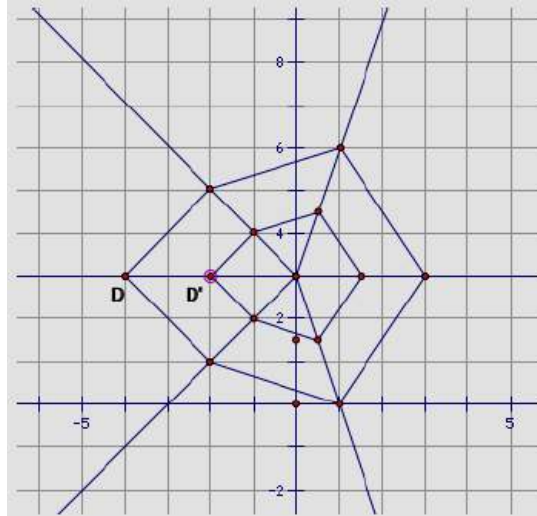

Instructional Strategies: G.SRT.1-3

Allow adequate time and hands-on activities for students to explore dilations visually and physically.

Use graph paper and rulers or dynamic geometry software to obtain images of a given figure under dilations having specified centers and scale factors. Carefully observe the images of lines passing through the center of dilation and those not passing through the center, respectively. A line segment passing through the center of dilation will simply be shortened or elongated but will lie on the same line, while the dilation of a line segment that does not pass through the center will be parallel to the original segment (this is intended as a clarification of Standard 1a).

Illustrate two-dimensional dilations using scale drawings and photocopies.

Measure the corresponding angles and sides of the original figure and its image to verify that the corresponding angles are congruent and the corresponding sides are proportional (i.e. stretched or shrunk by the same scale factor). Investigate the SAS and SSS criteria for similar triangles.

Use graph paper and rulers or dynamic geometry software to obtain the image of a given figure under a combination of a dilation followed by a sequence of rigid motions (or rigid motions followed by dilation).

Work backwards – given two similar figures that are related by dilation, determine the center of dilation and scale factor. Given two similar figures that are related by a dilation followed by a sequence of rigid motions, determine the parameters of the dilation and rigid motions that will map one onto the other.

Using the theorem that the angle sum of a triangle is 180° , verify that the AA criterion is equivalent to the AAA criterion. Given two triangles for which AA holds, use rigid motions to map a vertex of one triangle onto the corresponding vertex of the other in such a way that their corresponding sides are in line. Then show that dilation will complete the mapping of one triangle onto the other.

Students may be interested in scale models or experiences with blueprints and scale drawings (perhaps in a work related situation) to illustrate similarity.

Continued on next page

Common Misconceptions: G.SRT.1-3

Some students often do not recognize that congruence is a special case of similarity. Similarity with a scale factor equal to 1 becomes a congruency.

Students may not realize that similarities preserve shape, but not size. Angle measures stay the same, but side lengths change by a constant scale factor.

Students may incorrectly apply the scale factor. For example students will multiply instead of divide with a scale factor that reduces a figure or divide instead of multiply when enlarging a figure.

Some students often do not list the vertices of similar triangles in order. However, the order in which vertices are listed is preferred and especially important for similar triangles so that proportional sides can be correctly identified.

Geometry: Similarity, Right Triangles, and Trigonometry [\(G-SRT\)](#)

Cluster: *Understand similarity in terms of similarity transformations.*

Standard: G.SRT.2 Given two figures, use the definition of similarity in terms of similarity transformations to decide if they are similar; explain using similarity transformations the meaning of similarity for triangles as the equality of all corresponding pairs of angles and the proportionality of all corresponding pairs of sides.

Suggested Standards for Mathematical Practice (MP):

MP.3 Construct viable arguments and critique the reasoning of others.

MP.5 Use appropriate tools strategically.

MP.7 Look for and make use of structure.

Connections: See [G.SRT.1](#)

Common Misconceptions: See [G.SRT.1](#)

Explanations and Examples: G.SRT.2

Use the idea of dilation transformations to develop the definition of similarity. Understand that a similarity transformation is a rigid motion followed by a dilation.

Demonstrate that in a pair of similar triangles, corresponding angles are congruent (angle measure is preserved) and corresponding sides are proportional.

Determine that two figures are similar by verifying that angle measure is preserved and corresponding sides are proportional.

Students may use geometric simulation software to model transformations and demonstrate a sequence of transformations to show congruence or similarity of figures.

Examples:

- Are these two figures similar? Explain why or why not.

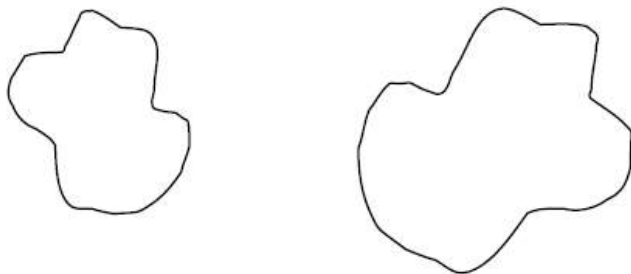

Continued on next page

Explanations and Examples: G.SRT.2

- In the picture below, line segments AD and BC intersect at X . Line segments AB and CD are drawn, forming two triangles $\triangle AXB$ and $\triangle CXD$.

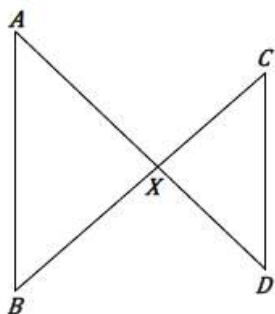

In each part a-d below, some additional assumptions about the picture are given. In each problem, determine whether the given assumptions are enough to prove that the two triangles are similar, and if so, what the correct correspondence of vertices is. If the two triangles must be similar, prove this result by describing a sequence of similarity transformations that maps one variable to the other. If not explain why not.

a. The lengths of AX and AD satisfy the equation $2AX = 3XD$.

b. The lengths AX , BX , CX , and DX satisfy the equation $\frac{AX}{BX} = \frac{DX}{CX}$.

c. Lines AB and CD are parallel.

d. $\angle XAB$ is congruent to angle $\angle XCD$.

Solution:

- We are given that $2AX = 3XD$. This is not enough information to prove similarity. To see that in a simple way draw an arbitrary triangle $\triangle AXB$. Extend AX and choose a point D on the extended line so that $2AX = 3XD$. Extend BX and choose a point C on the extended line so that $2BX = XC$. Now triangles AXB and CXD satisfy the given conditions but are not similar. (If you are extremely unlucky, AXB and CXD might be similar by a different correspondence of sides. If this happens, rotate the line BC a little bit. The lengths of AX , XD , BX , XC remain the same but the triangles are no longer similar.)
- We are given that $\frac{AX}{BX} = \frac{DX}{CX}$. Rearranging this proportion gives $\frac{AX}{DX} = \frac{BX}{CX}$. Let $k = \frac{AX}{DX}$. Suppose we rotate the triangle DXC 180 degrees about point X , as in part (a), so that the angle DXC coincides with angle AXB . Then dilate the triangle DXC by a factor of k about the center X . This dilation moves the point D to A , since $k(DX) = AX$, and moves C to B , since $k(CX) = BX$. Then since the dilation fixes X , and dilations take line segments to line segments, we see that the triangle DXC is mapped to triangle AXB . So the original triangle DXC is similar to AXB . (Note that we state the similarity so that the vertices of each triangle are written in corresponding order.)
- Again, rotate triangle DXC so that angle DXC coincides with angle AXB . Then the image of the side CD under this rotation is parallel to the original side CD , so the new side CD is still parallel to side AB . Now, apply a dilation about point X that moves the vertex C to point B . This dilation moves the line CD to a line through B parallel to the previous line CD . We already know that line AB is parallel to CD , so the dilation must move the line CD onto the line AB . Since the dilation moves D to a point on the ray XA and on the line AB , D must move to A . Therefore, the rotation and dilation map the triangle DXC to the triangle AXB . Thus DXC is similar to AXB .
- Suppose we draw the bisector of angle AXC , and reflect the triangle CXD across this angle bisector. This maps the segment XC onto the segment XA ; and since reflections preserve angles, it also maps segment XD onto segment XB . Since angle XCD is congruent to angle XAB , we also know that the image of side CD is parallel to side AB . Therefore, if we apply a dilation about the point X that takes the new point C to A , then the new line CD will be mapped onto the line AB , by the same reasoning used in (c). Therefore, the new point D is mapped to B , and thus the triangle XCD is mapped to triangle XAB . So triangle XCD is similar to triangle XAB . (Note that this is not the same correspondence we had in parts (b) and (c)!)

Instructional Strategies: See [G.SRT.1](#)

Geometry: Similarity, Right Triangles, and Trigonometry ([G-SRT](#))

Cluster: *Understand similarity in terms of similarity transformations.*

Standard: G.SRT.3 Use the properties of similarity transformations to establish the AA criterion for two triangles to be similar.

Suggested Standards for Mathematical Practice (MP):

MP.3 Construct viable arguments and critique the reasoning of others.

Connections: See [G.SRT.1](#)

Common Misconceptions: See [G.SRT.1](#)

Explanations and Examples: G.SRT.3

Show and explain that when two angle measures are known (AA), the third angle measure is also known (Third Angle Theorem).

Identify and explain that AA similarity is a sufficient condition for two triangles to be similar.

Examples:

- Are all right triangles similar to one another? How do you know?
- What is the least amount of information needed to prove two triangles are similar? How do you know?
- Using a ruler and a protractor, prove AA similarity.

Instructional Strategies: See [G.SRT.1](#)

Using the theorem that the angle sum of a triangle is 180° , verify that the AA criterion is equivalent to the AAA criterion. Given two triangles for which AA holds, use rigid motions to map a vertex of one triangle onto the corresponding vertex of the other in such a way that their corresponding sides are in line. Then show that dilation will complete the mapping of one triangle onto the other.

Geometry: Similarity, Right Triangles, and Trigonometry (G-SRT)

Cluster: *Prove theorems involving similarity.*

Standard: G.SRT.4 Prove theorems about triangles. *Theorems include: a line parallel to one side of a triangle divides the other two proportionally, and conversely; the Pythagorean Theorem proved using triangle similarity.*

Suggested Standards for Mathematical Practice (MP):

- MP.3 Construct viable arguments and critique the reasoning of others.
- MP.5 Use appropriate tools strategically.

Connections: G.SRT.4-5

The Pythagorean theorem and its converse are proved and applied in Grade 8. In high school, another proof, based on similar triangles, is presented.

The alternate interior angle theorem and its converse, as well as properties of parallelograms, are established informally in Grade 8 and proved formally in high school.

Explanations and Examples: G.SRT.4

Use AA, SAS, SSS similarity theorems to prove triangles are similar.

Use triangle similarity to prove other theorems about triangles

- o Prove a line parallel to one side of a triangle divides the other two proportionally, and it's converse
- o Prove the Pythagorean Theorem using triangle similarity.

Students may use geometric simulation software to model transformations and demonstrate a sequence of transformations to show congruence or similarity of figures.

Examples:

- Prove that if two triangles are similar, then the ratio of corresponding altitudes is equal to the ratio of corresponding sides.
- How does the Pythagorean Theorem support the case for triangle similarity?
 - o View the video below and create a visual proving the Pythagorean Theorem using similarity.
http://www.youtube.com/watch?v=LrS5_l-gk94
- To prove the Pythagorean Theorem using triangle similarity:
We can cut a right triangle into two parts by dropping a perpendicular onto the hypotenuse.
Since these triangles and the original one have the same angles, all three are similar.

Therefore

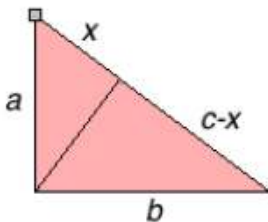

$$\begin{aligned}\frac{x}{a} &= \frac{a}{c}, & \frac{c-x}{b} &= \frac{b}{c} \\ x &= \frac{a^2}{c}, & c-x &= \frac{b^2}{c} \\ x + (c-x) &= c \\ \frac{a^2}{c} + \frac{b^2}{c} &= c \\ a^2 + b^2 &= c^2\end{aligned}$$

<http://www.math.ubc.ca/~cass/euclid/java/html/pythagorassimilarity.html>

Continued on next page

Instructional Strategies: G.SRT.4-5

Review triangle congruence criteria and similarity criteria, if it has already been established.

Review the angle sum theorem for triangles, the alternate interior angle theorem and its converse, and properties of parallelograms. Visualize it using dynamic geometry software.

Using SAS and the alternate interior angle theorem, prove that a line segment joining midpoints of two sides of a triangle is parallel to and half the length of the third side. Apply this theorem to a line segment that cuts two sides of a triangle proportionally.

Generalize this theorem to prove that the figure formed by joining consecutive midpoints of sides of an arbitrary quadrilateral is a parallelogram. (This result is known as the Midpoint Quadrilateral Theorem or Varignon's Theorem.)

Use cardboard cutouts to illustrate that the altitude to the hypotenuse divides a right triangle into two triangles that are similar to the original triangle. Then use AA to prove this theorem. Then, use this result to establish the Pythagorean relationship among the sides of a right triangle ($a^2 + b^2 = c^2$) and thus obtain an algebraic proof of the Pythagorean Theorem.

Prove that the altitude to the hypotenuse of a right triangle is the geometric mean of the two segments into which its foot divides the hypotenuse.

Prove the converse of the Pythagorean Theorem, using the theorem itself as one step in the proof. Some students might engage in an exploration of Pythagorean Triples (e.g., 3-4-5, 5-12-13, etc.), which provides an algebraic extension and an opportunity to explore patterns.

Common Misconceptions: G.SRT.4-5

Some students may confuse the alternate interior angle theorem and its converse as well as the Pythagorean theorem and its converse.

Geometry: Similarity, Right Triangles, and Trigonometry [\(G-SRT\)](#)

Cluster: *Prove theorems involving similarity.*

Standard: G.SRT.5 Use congruence and similarity criteria for triangles to solve problems and to prove relationships in geometric figures.

Suggested Standards for Mathematical Practice (MP):

MP.3 Construct viable arguments and critique the reasoning of others. MP.6 Attend to precision.
MP.4 Model with mathematics. MP.7 Look for and make use of structure.

Connections: See [G.SRT.4](#)

Common Misconceptions: See [G.SRT.4](#)

Explanations and Examples: G.SRT.5

Similarity postulates include SSS, SAS, and AA.

Congruence postulates include SSS, SAS, ASA, AAS, and H-L.

Apply triangle congruence and triangle similarity to solve problem situations (e.g., indirect measurement, missing sides/angle measures, side splitting).

Students may use geometric simulation software to model transformations and demonstrate a sequence of transformations to show congruence or similarity of figures.

Examples:

- This diagram is made up of four regular pentagons that are all the same size.

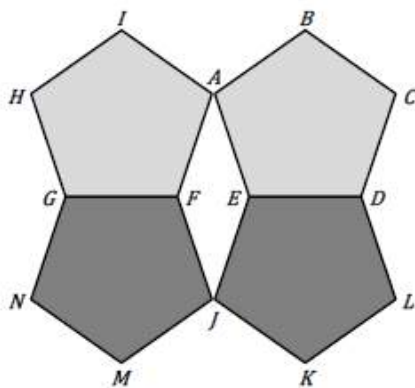

- Find the measure of $\angle AEJ$
- Find the measure of $\angle BKF$
- Find the measure of $\angle KJM$

Instructional Strategies: 8.G.6-8

Geometry: Similarity, Right Triangles, and Trigonometry [\(G-SRT\)](#)

Cluster: *Define trigonometric ratios and solve problems involving right triangles.*

Standard: G.SRT.6 Understand that by similarity, side ratios in right triangles are properties of the angles in the triangle, leading to definitions of trigonometric ratios for acute angles.

Suggested Standards for Mathematical Practice (MP):

MP.2 Reason abstractly and quantitatively.

MP.7 Look for and make use of structure.

MP.6 Attend to precision.

MP.8 Look for and express regularity in repeated reasoning.

Connections: G.SRT.6-8

Trigonometry is not introduced until high school. Right triangle trigonometry (a geometry topic) has implications when studying algebra and functions. For example, trigonometric ratios are functions of the size of an angle, the trigonometric functions can be revisited after radian measure has been studied, and the Pythagorean theorem can be used to show that $(\sin A)^2 + (\cos A)^2 = 1$.

Explanations and Examples: G.SRT.6

Students may use applets to explore the range of values of the trigonometric ratios as θ ranges from 0 to 90 degrees. Use the characteristics of similar figures to justify trigonometric ratios.

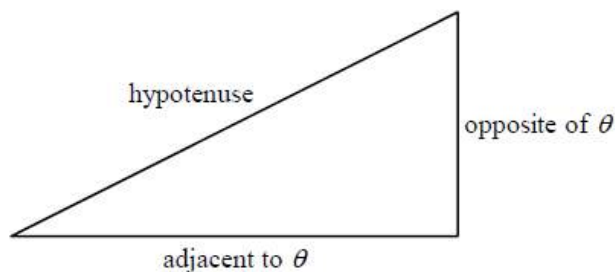

$$\text{sine of } \theta = \sin \theta = \frac{\text{opposite}}{\text{hypotenuse}}$$

$$\text{cosine of } \theta = \cos \theta = \frac{\text{adjacent}}{\text{hypotenuse}}$$

$$\text{tangent of } \theta = \tan \theta = \frac{\text{opposite}}{\text{adjacent}}$$

$$\text{cosecant of } \theta = \csc \theta = \frac{\text{hypotenuse}}{\text{opposite}}$$

$$\text{secant of } \theta = \sec \theta = \frac{\text{hypotenuse}}{\text{adjacent}}$$

$$\text{cotangent of } \theta = \cot \theta = \frac{\text{adjacent}}{\text{opposite}}$$

Examples:

- Find the sine, cosine, and tangent of x .

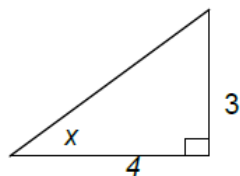

Continued on next page

Explanations and Examples: G.SRT.6

- Explain why the sine of x is the same regardless of which triangle is used to find it in the figure below.

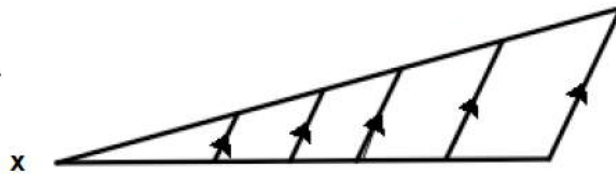

Instructional Strategies: G.SRT.6-8

Review vocabulary (opposite and adjacent sides, legs, hypotenuse and complementary angles) associated with right triangles.

Make cutouts or drawings of right triangles or manipulate them on a computer screen using dynamic geometry software and ask students to measure side lengths and compute side ratios. Observe that when triangles satisfy the AA criterion, corresponding side ratios are equal. Side ratios are given standard names, such as sine, cosine and tangent. Allow adequate time for students to discover trigonometric relationships and progress from concrete to abstract understanding of the trigonometric ratios.

Show students how to use the trigonometric function keys on a calculator. Also, show how to find the measure of an acute angle if the value of its trigonometric function is known.

Investigate sines and cosines of complementary angles, and guide students to discover that they are equal to one another. Point out to students that the “co” in cosine refers to the “sine of the complement.”

Observe that, as the size of the acute angle increases, sines and tangents increase while cosines decrease. Stress trigonometric terminology by the history of the word “sine” and the connection between the term “tangent” in trigonometry and tangents to circles.

Have students make their own diagrams showing a right triangle with labels showing the trigonometric ratios. Although students like mnemonics such as SOHCAHTOA, *these are not a substitute for conceptual understanding*. Some students may investigate the reciprocals of sine, cosine, and tangent to discover the other three trigonometric functions.

Use the Pythagorean theorem to obtain exact trigonometric ratios for 30° , 45° , and 60° angles. Use cooperative learning in small groups for discovery activities and outdoor measurement projects.

Have students work on applied problems and project, such as measuring the height of the school building or a flagpole, using clinometers and the trigonometric functions.

Common Misconceptions: G.SRT.6-8

Some students believe that right triangles must be oriented a particular way.

Some students do not realize that opposite and adjacent sides need to be identified with reference to a particular acute angle in a right triangle.

Some students believe that the trigonometric ratios defined in this cluster apply to all triangles, but they are only defined for acute angles in right triangles.

Geometry: Similarity, Right Triangles, and Trigonometry [\(G-SRT\)](#)

Cluster: *Define trigonometric ratios and solve problems involving right triangles.*

Standard: G.SRT.7 Explain and use the relationship between the sine and cosine of complementary angles.

Suggested Standards for Mathematical Practice (MP):

MP.2 Reason abstractly and quantitatively.

MP.3 Construct viable arguments and critique the reasoning of others.

Connections: See [G.SRT.6](#)

Common Misconceptions: See [G.SRT.6](#)

Explanations and Examples: G.SRT.7

Calculate sine and cosine ratios for acute angles in a right triangle when given two side lengths.

Use a diagram of a right triangle to explain that for a pair of complementary angles A and B , the sine of angle A is equal to the cosine of angle B and the cosine of angle A is equal to the sine of angle B .

Geometric simulation software applets and graphing calculators can be used to explore the relationship between sine and cosine.

Examples:

- What is the relationship between cosine and sine in relation to complementary angles?
 - Construct a table demonstrating the relationship between sine and cosine of complementary angles.
- Find the second acute angle of a right triangle given that the first acute angle has a measure of 39° .
- Complete the following statement: If $\sin 30^\circ = \frac{1}{2}$, then the \cos _____ = $\frac{1}{2}$.
- Find the sine and cosine of angle θ in the triangle below. What do you notice?

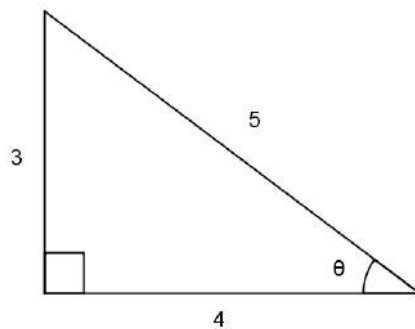

Instructional Strategies: See [G.SRT.6](#)

Geometry: Similarity, Right Triangles, and Trigonometry ([G-SRT](#))

Cluster: *Define trigonometric ratios and solve problems involving right triangles.*

Standard: G.SRT.8 Use trigonometric ratios and the Pythagorean Theorem to solve right triangles in applied problems. (★)

Suggested Standards for Mathematical Practice (MP):

MP.1 Make sense of problems and persevere in solving them. MP.5 Use appropriate tools strategically.
MP.4 Model with mathematics.

Connections: See [G.SRT.6](#)

Common Misconceptions: See [G.SRT.6](#)

Explanations and Examples: G.SRT.8

Use angle measures to estimate side lengths (e.g., The side across from a 33° angle will be shorter than the side across from a 57° angle).

Use side lengths to estimate angle measures (e.g., The angle opposite of a 10 cm side will be larger than the angle across from a 9 cm side).

Draw right triangles that describe real world problems and label the sides and angles with their given measures. Solve application problems involving right triangles, including angle of elevation and depression, navigation, and surveying.

Students may use graphing calculators or programs, tables, spreadsheets, or computer algebra systems to solve right triangle problems.

Examples:

- Find the height of a flagpole to the nearest tenth if the angle of elevation of the sun is 28° and the shadow of the flagpole is 50 feet.

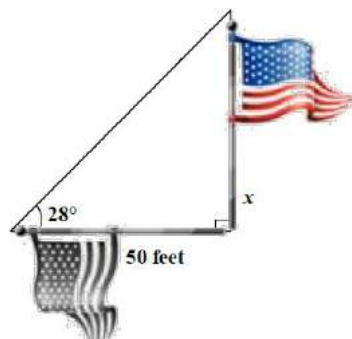

- A teenager whose eyes are 5 feet above ground level is looking into a mirror on the ground and can see the top of a building that is 30 feet away from the teenager. The angle of elevation from the center of the mirror to the top of the building is 75° . How tall is the building? How far away from the teenager's feet is the mirror?
- While traveling across flat land, you see a mountain directly in front of you. The angle of elevation to the peak is 3.5° . After driving 14 miles closer to the mountain, the angle of elevation is $9^\circ 24' 36''$. Explain how you would set up the problem, and find the approximate height of the mountain.

Instructional Strategies: See [G.SRT.6](#)

Geometry: Circles (G-C)

Cluster: *Understand and apply theorems about circles.*

Standard: G.C.1 Prove that all circles are similar.

Suggested Standards for Mathematical Practice (MP):

MP.3 Construct viable arguments and critique the reasoning of others.

MP.5 Use appropriate tools strategically.

Connections: G.C.1-2

The expectation is to emphasize the similarity of all circles.

Explanations and Examples: G.C.1

Using the fact that the ratio of diameter to circumference is the same for circles, prove that all circles are similar. Prove that all circles are similar by showing that for a dilation centered at the center of a circle, the preimage and the image have equal central angle measures.

Students may use geometric simulation software to model transformations and demonstrate a sequence of transformations to show congruence or similarity of figures.

Examples:

- Show that the two given circles are similar by stating the necessary transformations from **C** to **D**.
 - **C**: center (2, 3) radius 5
 - **D**: center (-1, 4) radius 10
- Draw or find examples of several different circles. In what ways are they related? How can you describe this relationship in terms of geometric ideas? Form a hypothesis and prove it.

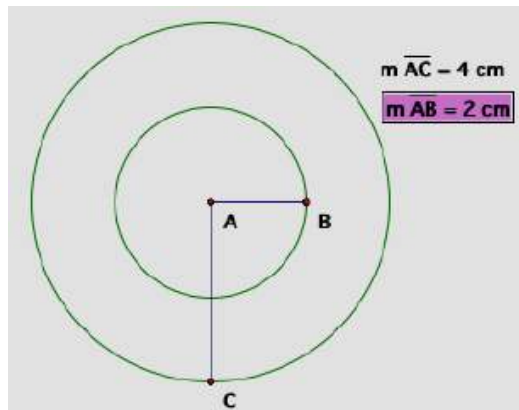

Continued on next page

Instructional Strategies: G.C.1-3

Given any two circles in a plane, show that they are related by dilation. Guide students to discover the center and scale factor of this dilation and make a conjecture about all dilations of circles.

Starting with the special case of an angle inscribed in a semicircle, use the fact that the angle sum of a triangle is 180° to show that this angle is a right angle. Using dynamic geometry, students can grab a point on a circle and move it to see that the measure of the inscribed angle passing through the endpoints of a diameter is always 90° . Then extend the result to any inscribed angles. For inscribed angles, proofs can be based on the fact that the measure of an exterior angle of a triangle equals the sum of the measures of the nonadjacent angles. Consider cases of acute or obtuse inscribed angles.

Use properties of congruent triangles and perpendicular lines to prove theorems about diameters, radii, chords, and tangent lines.

Use formal geometric constructions to construct perpendicular bisectors of the sides and angle bisectors of a given triangle. Their intersections are the centers of the circumscribed and inscribed circles, respectively.

Dissect an inscribed quadrilateral into triangles, and use theorems about triangles to prove properties of these quadrilaterals and their angles.

Challenge students to generalize the results about angle sums of triangles and quadrilaterals to a corresponding result for n -gons.

Common Misconceptions: G.C.1-3

Students sometimes confuse inscribed angles and central angles. For example they will assume that the inscribed angle is equal to the arc like a central angle.

Students may think they can tell by inspection whether a line intersects a circle in exactly one point. It may be beneficial to formally define a tangent line as the line perpendicular to a radius at the point where the radius intersects the circle.

Students may confuse the segment theorems. For example, they will assume that the inscribed angle is equal to the arc like a central angle.

Geometry: Circles [\(G-C\)](#)

Cluster: *Understand and apply theorems about circles.*

Standard: G.C.2 Identify and describe relationships among inscribed angles, radii, and chords. *Include the relationship between central, inscribed, and circumscribed angles; inscribed angles on a diameter are right angles; the radius of a circle is perpendicular to the tangent where the radius intersects the circle.*

Suggested Standards for Mathematical Practice (MP):

MP.1 Make sense of problems and persevere in solving them. MP.5 Use appropriate tools strategically.
MP.3 Construct viable arguments and critique the reasoning of others. MP.6 Attend to precision.

Connections: See [G.C.1](#)

Common Misconceptions: See [G.C.1](#)

Explanations and Examples: G.C.2

Identify central angles, inscribed angles, circumscribed angles, diameters, radii, chords, and tangents.

Describe the relationship between a central angle and the arc it intercepts.

Describe the relationship between an inscribed angle and the arc it intercepts.

Describe the relationship between a circumscribed angle and the arcs it intercepts.

Recognize that an inscribed angle whose sides intersect the endpoints of the diameter of a circle is a right angle.

Recognize that the radius of a circle is perpendicular to the tangent where the radius intersects the circle.

Examples:

- Given the circle below with radius of 10 and chord length of 12, find the distance from the chord to the center of the circle.

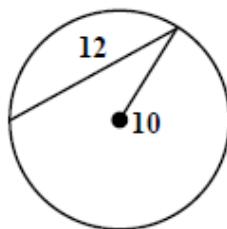

Continued on next page

Explanations and Examples: G.C.2

- Find the unknown length in the picture below.

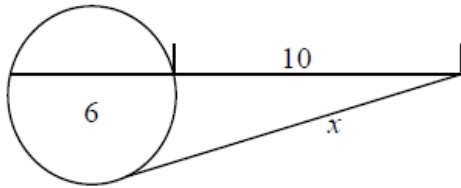

Solution:

The theorem for a secant segment and a tangent segment that share an endpoint not on the circle states that for the picture below secant segment QR and the tangent segment SR share an endpoint R, not on the circle. Then the length of SR squared is equal to the product of the lengths of QR and KR.

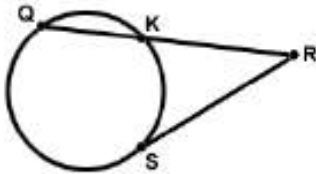

So for the example above

$$x^2 = 16 \cdot 10$$
$$x^2 = 160$$
$$x = \sqrt{160} = 4\sqrt{10} \approx 12.6$$

- How does the angle between a tangent to a circle and the line connecting the point of tangency and the center of the circle change as you move the tangent point?

Instructional Strategies: See [G.C.1](#)

Geometry: Circles (G-C)

Cluster: *Understand and apply theorems about circles.*

Standard: G.C.3 Construct the inscribed and circumscribed circles of a triangle, and prove properties of angles for a quadrilateral inscribed in a circle.

Suggested Standards for Mathematical Practice (MP):

MP.3 Construct viable arguments and critique the reasoning of others.

MP.5 Use appropriate tools strategically.

Connections:

Constructing inscribed and circumscribed circles of a triangle is an application of the formal constructions studied in G.CO.12.

Explanations and Examples: G.C.3

Define the terms inscribed, circumscribed, angle bisector, and perpendicular bisector.

Construct the inscribed circle whose center is the point of intersection of the angle bisectors (*the incenter*).

Construct the circumscribed circle whose center is the point of intersection of the perpendicular bisectors of each side of the triangle (*the circumcenter*).

Apply the Arc Addition Postulate to solve for missing arc measures.

Prove that opposite angles in an inscribed quadrilateral are supplementary.

Using definitions, properties, and theorems, prove properties of angles for a quadrilateral inscribed in a circle.

Students may use geometric simulation software to make geometric constructions.

Examples:

- The following diagram shows a circle that just touches the sides of a right triangle whose sides are 3 units, 4 units, and 5 units long.

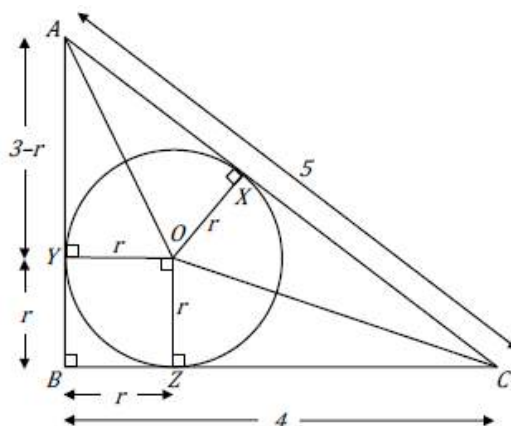

Explain why triangles AOX and AOY are congruent.

- What can you say about the measures of the line segments CX and CZ ?
- Find r , the radius of the circle. Explain your work clearly and show all your calculations.

Continued on next page

Explanations and Examples: G.C.3

- The following diagram shows a circle that just touches the sides of a right triangle whose sides are 5 units, 12 units, and 13 units long. Draw radius lines as in the previous task and find the radius of the circle in this 5, 12, 13 right triangle. Explain your work and show your calculations.

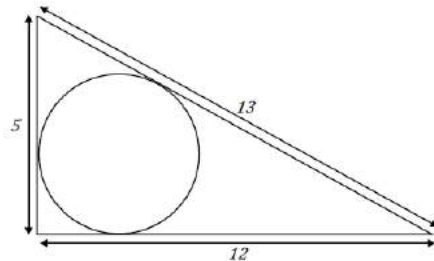

- Given the inscribed quadrilateral below prove that $\angle B$ is supplementary to $\angle D$.

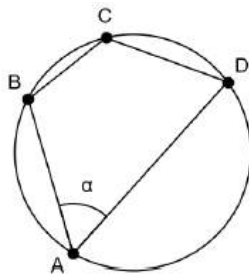

- You have been asked to place a fire hydrant so that it is an equal distance from three locations indicated on the following map.

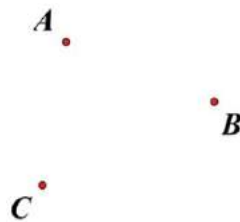

- Show how to fold your paper to physically construct this point as an intersection of two creases.
- Explain why the above construction works, and in particular why you only need to make two creases.

Solution: (This task connects to standards G.CO.12-13)

- Fold and crease the paper so that line segment point **A** lands onto point **B**. Do the same so that point **A** lands on point **C**. The intersection of the two creases is the point we want.
- Since the desired location is an equal distance from three non-collinear points, we are looking for the center of the circle passing through these three points. This corresponds to the center of the circle circumscribed about the triangle **ABC**. The center of the circumcircle, called the circumcenter, can be found by constructing the perpendicular bisectors of the three sides of the triangle (precisely the creases made in the paper on the previous step). Since the perpendicular bisectors are concurrent, it is sufficient to construct only two of the three perpendicular bisectors

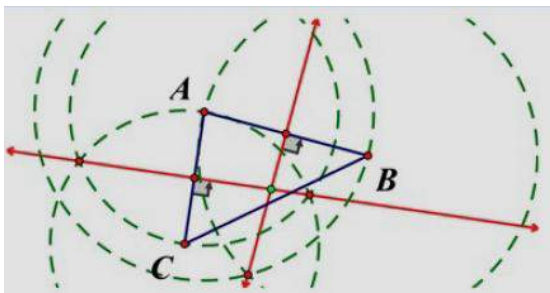

The concurrency of the perpendicular bisectors can be argued as follows: Let **P** be the green dot in the above diagram, the intersection of the perpendicular bisectors of **AB** and **AC**. By virtue of **P** being on the perpendicular bisector of **AB**, **P** is equidistant from **A** and **B**, i.e., $PA = PB$. Similarly, by virtue of being on the perpendicular bisector of **AC**, we have $PA = PC$. But this implies that $PB = PC$, i.e., that **P** is also on the perpendicular bisector of **BC**, demonstrating that **P** indeed lies on all three perpendicular bisectors

Explanations and Examples: G.C.5

- The amusement park has discovered that the brace that provides stability to the Ferris wheel has been damaged and needs work. The arc length of steel reinforcement that must be replaced is between the two seats shown below. If the sector area is 28.25 ft^2 and the radius is 12 feet, what is the length of steel that must be replaced? Describe the steps you used to find your answer.

Brace that provides stability to the ride.



- If the amusement park owners wanted to decorate each sector of this Ferris wheel with a different color of fabric, how much of each color fabric would they need to purchase? The area to be covered is described by an arc length of 5.9 feet. The circle has a radius of 15 feet. Describe the steps you used to find your answer.

Instructional Strategies: G.C.5

Begin by calculating lengths of arcs that are simple fractional parts of a circle (e.g. $\frac{1}{6}$), and do this for circles of various radii so that students discover a proportionality relationship.

Provide plenty of practice in assigning radian measure to angles that are simple fractional parts of a straight angle. Stress the definition of radian by considering a central angle whose intercepted arc has its length equal to the radius, making the constant of proportionality 1. Students who are having difficulty understanding radians may benefit from constructing cardboard sectors whose angles are one radian. Use a ruler and string to approximate such an angle.

Compute areas of sectors by first considering them as fractional parts of a circle. Then, using proportionality, derive a formula for their area in terms of radius and central angle. Do this for angles that are measured both in degrees and radians and note that the formula is much simpler when the angles are measured in radians.

Derive formulas that relate degrees and radians.

Introduce arc measures that are equal to the measures of the intercepted central angles in degrees or radians. Emphasize appropriate use of terms, such as, angle, arc, radian, degree, and sector.

Common Misconceptions: G.C.5

Sectors and segments are often used interchangeably in everyday conversation. Care should be taken to distinguish these two geometric concepts.

The formulas for converting radians to degrees and vice versa are easily confused. Knowing that the degree measure of given angle is always a number larger than the radian measure can help students use the correct unit.

Geometry: Expressing Geometric Properties with Equations [\(G-GPE\)](#)

Cluster: *Translate between the geometric description and the equation for a conic section.*

Standard: G.GPE.1 Derive the equation of a circle of given center and radius using the Pythagorean Theorem; complete the square to find the center and radius of a circle given by an equation.

Suggested Standards for Mathematical Practice (MP):

MP.2 Reason abstractly and quantitatively.

MP.3 Construct viable arguments and critique the reasoning of others.

MP.7 Look for and make use of structure. MP.8 Look for and express regularity in repeated reasoning.

Connections: G.GPE.1-2

In Grade 8 the Pythagorean theorem was applied to find the distance between two particular points. In high school, the application is generalized to obtain formulas related to conic sections.

Quadratic functions and the method of completing the square are studied in the domain of interpreting functions. The methods are applied here to transform a quadratic equation representing a conic section into standard form.

Explanations and Examples: G.GPE.1

Connect G.GPE.1 to G.GPE.4 and reasoning with triangles, limited to right triangles, e.g., derive the equation for a line through two points using similar right triangles.

Identify the center and radius of a circle given its equation.

Draw a right triangle with a horizontal leg, a vertical leg, and the radius of a circle as its hypotenuse.

Use the Pythagorean Theorem, the coordinates of a circle's center, and the circle's radius to write the equation of the circle.

Convert an equation of a circle in general (quadratic) form to standard form by completing the square.

Identify the center and radius of a circle given its equation.

Students may use geometric simulation software to explore the connection between circles and the Pythagorean Theorem.

Examples:

- Write an equation for a circle with a radius of 2 units and center at (1, 3).
- Write an equation for a circle given that the endpoints of the diameter are (−2, 7) and (4, −8).
- Find the center and radius of the circle $4x^2 + 4y^2 - 4x + 2y - 1 = 0$.
- A circle is tangent to the x-axis and y-axis in the first quadrant. A point of tangency has coordinates (4, 0). Find the equation of the circle.
- A circle is inscribed in an equilateral triangle. The equilateral triangle lies in the first quadrant with one vertex at the origin and second vertex at $(4\sqrt{3}, 0)$.

Continued on next page

Instructional Strategies: G.GPE.1

Review the definition of a circle as a set of points whose distance from a fixed point is constant.

Review the algebraic method of completing the square and demonstrate it geometrically.

Illustrate conic sections geometrically as cross sections of a cone.

Use the Pythagorean theorem to derive the distance formula. Then, use the distance formula to derive the equation of a circle with a given center and radius, beginning with the case where the center is the origin.

Starting with any quadratic equation in two variables (x and y) in which the coefficients of the quadratic terms are equal, complete the squares in both x and y and obtain the equation of a circle in standard form.

Given two points, find the equation of the circle passing through one of the points and having the other as its center.

Import images of circle from fields from Google Earth into a coordinate grid system and find their equations.

Common Misconceptions: G.GPE.1-2

Because new vocabulary is being introduced in this cluster, remembering the names of the conic sections can be problematic for some students.

The Euclidean distance formula involves squared, subscripted variables whose differences are added.

The notation and multiplicity of steps can be a serious stumbling block for some students.

The method of completing the square is a multi-step process that takes time to assimilate. A geometric demonstration of completing the square can be helpful in promoting conceptual understanding.

Geometry: Expressing Geometric Properties with Equations ([G-GPE](#))

Cluster: *Translate between the geometric description and the equation for a conic section.*

Standard: G.GPE.2 Derive the equation of a parabola given a focus and directrix.

Suggested Standards for Mathematical Practice (MP):

MP.2 Reason abstractly and quantitatively.

MP.3 Construct viable arguments and critique the reasoning of others.

MP.7 Look for and make use of structure.

MP.8 Look for and express regularity in repeated reasoning.

Connections: See [G.GPE.1](#)

Common Misconceptions: See [G.GPE.1](#)

Explanations and Examples: G.GPE.2

The directrix should be parallel to a coordinate axis.

Find the distance from a point on the parabola (x, y) to the directrix.

Find the distance from a point on the parabola (x, y) to the focus using the distance formula (Pythagorean Theorem).

Equate the two distance expressions for a parabola to write its equation.

Identify the focus and directrix of a parabola when given its equation.

Students may use geometric simulation software to explore parabolas.

Examples:

- Write and graph an equation for a parabola with focus $(2, 3)$ and directrix $y = 1$.
- Given the equation $20(y - 5) = (x + 3)^2$, find the focus, vertex and directrix.

Solution: The vertex is at $(-3, 5)$ and to find the vertex we know that the constant of the unsquared term is 20. Since $4p = 20$ then $p = 5$. The focus is 5 units above the vertex at $(-3, 5+5)$ or $(-3, 10)$. The directrix is 5 units below the vertex so $y = 0$.

- A parabola has focus $(-2, 1)$ and directrix $y = -3$. Determine whether or not the point $(2, 1)$ is part of the parabola. Justify your answer.

Instructional Strategies: G.GPE.2

Define a parabola as a set of points satisfying the condition that their distance from a fixed point (focus) equals their distance from a fixed line (directrix). Start with a horizontal directrix and a focus on the y -axis, and use the distance formula to obtain an equation of the resulting parabola in terms of y and x^2 . Next use a vertical directrix and a focus on the x -axis to obtain an equation of a parabola in terms of x and y^2 . Make generalizations in which the focus may be any point, but the directrix is still either horizontal or vertical. Allow sufficient time for students to become familiar with new vocabulary and notation.

Given y as a quadratic equation of x (or x as a quadratic function of y), complete the square to obtain an equation of a parabola in standard form.

Identify the vertex of a parabola when its equation is in standard form and show that the vertex is halfway between the focus and directrix.

Investigate practical applications of parabolas and paraboloids.

Geometry: Expressing Geometric Properties with Equations (G-GPE)

Cluster: *Use coordinates to prove simple geometric theorems algebraically.*

Standard: G.GPE.4 Use coordinates to prove simple geometric theorems algebraically. *For example, prove or disprove that a figure defined by four given points in the coordinate plane is a rectangle; prove or disprove that the point $(1, \sqrt{3})$ lies on the circle centered at the origin and containing the point $(0, 2)$.*

Suggested Standards for Mathematical Practice (MP):

MP.2 Reason abstractly and quantitatively.

MP.7 Look for use and make of structure.

MP.3 Construct viable arguments and critique the reasoning of others.

Connections: G.GPE.4-7

Rates of change and graphs of linear equations were studied in Grade 8 and generalized in the Functions and Geometry Conceptual Categories in high school. Therefore, an alternative way to define the slope of a line is to call it the tangent of an angle of inclination of the line.

Explanations and Examples: G.GPE.4

Represent the vertices of a figure in the coordinate plane using variables.

Use coordinates to prove or disprove a claim about a figure.

For example: use slope to determine if sides are parallel, intersecting, or perpendicular; use the distance formula to determine if sides are congruent or to decide if a point is inside a circle, outside a circle, or on the circle; use the midpoint formula or the distance formula to decide if a side has been bisected.

Students may use geometric simulation software to model figures and prove simple geometric theorems.

Examples:

- Use slope and distance formula to verify the polygon formed by connecting the points $(-3, -2)$, $(5, 3)$, $(9, 9)$, $(1, 4)$ is a parallelogram.
- Prove or disprove that triangle ABC with coordinates $A(-1, 2)$, $B(1, 5)$, $C(-2, 7)$ is an isosceles right triangle.
- Take a picture or find a picture which includes a polygon. Overlay the picture on a coordinate plane (manually or electronically). Determine the coordinates of the vertices. Classify the polygon. Use the coordinates to justify the classification.

Instructional Strategies: G.GPE.4-7

Review the concept of slope as the rate of change of the y -coordinate with respect to the x -coordinate for a point moving along a line, and derive the slope formula.

Use similar triangles to show that every nonvertical line has a constant slope.

Review the point-slope, slope-intercept and standard forms for equations of lines.

Investigate pairs of lines that are known to be parallel or perpendicular to each other and discover that their slopes are either equal or have a product of -1 , respectively.

Continued on next page

Instructional Strategies: G.GPE.4-7

Pay special attention to the slope of a line and its applications in analyzing properties of lines.

Allow adequate time for students to become familiar with slopes and equations of lines and methods of computing them.

Use slopes and the Euclidean distance formula to solve problems about figures in the coordinate plane such as:

- Given three points, are they vertices of an isosceles, equilateral, or right triangle?
- Given four points, are they vertices of a parallelogram, a rectangle, a rhombus, or a square?
- Given the equation of a circle and a point, does the point lie outside, inside, or on the circle?
- Given the equation of a circle and a point on it, find an equation of the line tangent to the circle at that point.
- Given a line and a point not on it, find an equation of the line through the point that is parallel to the given line.
- Given a line and a point not on it, find an equation of the line through the point that is perpendicular to the given line.
- Given the equations of two non-parallel lines, find their point of intersection.

Given two points, use the distance formula to find the coordinates of the point halfway between them. Generalize this for two arbitrary points to derive the midpoint formula.

Use linear interpolation to generalize the midpoint formula and find the point that partitions a line segment in any specified ratio.

Given the vertices of a triangle or a parallelogram, find the equation of a line containing the altitude to a specified base and the point of intersection of the altitude and the base. Use the distance formula to find the length of that altitude and base, and then compute the area of the figure.

Common Misconceptions: G.GPE.4-7

Students may claim that a vertical line has infinite slopes. This suggests that infinity is a number. Since applying the slope formula to a vertical line leads to division by zero, we say that the slope of a vertical line is undefined. Also, the slope of a horizontal line is 0. Students often say that the slope of vertical and/or horizontal lines is “no slope,” which is incorrect.

Geometry: Expressing Geometric Properties with Equations ([G-GPE](#))

Cluster: *Use coordinates to prove simple geometric theorems algebraically.*

Standard: G.GPE.5 Prove the slope criteria for parallel and perpendicular lines and use them to solve geometric problems (e.g., find the equation of a line parallel or perpendicular to a given line that passes through a given point).

Suggested Standards for Mathematical Practice (MP):

MP.3 Construct viable arguments and critique the reasoning of others.

MP.8 Look for and express regularity in repeated reasoning.

Connections: See [G.GPE.4](#)

Common Misconceptions: See [G.GPE.4](#)

Explanations and Examples: G.GPE.5

Relate work on parallel lines to standard A.REI.5 involving systems of equations having no solution or infinitely many solutions.

Lines can be horizontal, vertical or neither.

Prove that the slopes of parallel lines are equal.

Prove that the product of the slopes of perpendicular lines is -1 .

Write the equation of a line parallel or perpendicular to a given line, passing through a given point.

Students may use a variety of different methods to construct a parallel or perpendicular line to a given line and calculate the slopes to compare relationships.

Examples:

- Find the equation of a line perpendicular to $3x + 5y + 15$ through the point $(-3, 2)$.
- Find an equation of a line perpendicular to $y = 3x - 4$ that passes through $(3, 4)$.
- Verify that the distance between two parallel lines is constant. Justify your answer.

Instructional Strategies: See [G.GPE.4](#)

Allow students to explore and make conjectures about relationships between lines and segments using a variety of methods.

Discuss the role of algebra in providing a precise means of representing a visual image.

Geometry: Expressing Geometric Properties with Equations ([G-GPE](#))

Cluster: *Use coordinates to prove simple geometric theorems algebraically.*

Standard: G.GPE.6 Find the point on a directed line segment between two given points that partitions the segment in a given ratio.

Suggested Standards for Mathematical Practice (MP):

MP.2 Reason abstractly and quantitatively.

MP.7 Look for and make use of structure

MP.8 Look for and express regularity in repeated reasoning.

Connections: See [G.GPE.4](#)

Common Misconceptions: See [G.GPE.4](#)

Explanations and Examples: G.GPE.6

Students may use geometric simulation software to model figures or line segments.

Examples:

- Given $A(3, 2)$ and $B(6, 11)$,
 - Find the point that divides the line segment AB two-thirds of the way from A to B .

Solution:

The point two-thirds of the way from A to B has an x -coordinate two-thirds of the way from 3 to 6 and a y -coordinate two-thirds of the way from 2 to 11. So $(5, 8)$ is the point that is two-thirds from point A to B .

- Find the midpoint of the line segment AB .
- For the line segment whose endpoints are $(0, 0)$ and $(4, 3)$, find the point that partitions the segment into a ratio of 3 to 2.

Solution:

$$x = \frac{(2 \cdot 0) + (3 \cdot 4)}{(3 + 2)} = \frac{12}{5} \quad y = \frac{(2 \cdot 0) + (3 \cdot 3)}{(3 + 2)} = \frac{9}{5}, \text{ so the point is } \left(\frac{12}{5}, \frac{9}{5}\right)$$

Instructional Strategies: See [G.GPE.4](#)

Geometry: Expressing Geometric Properties with Equations ([G-GPE](#))

Cluster: *Use coordinates to prove simple geometric theorems algebraically.*

Standard: G.GPE.7 Use coordinates to compute perimeters of polygons and areas of triangles and rectangles, e.g., using the distance formula. (★)

Suggested Standards for Mathematical Practice (MP):

MP.1 Make sense of problems and persevere in solving them. MP.5 Use appropriate tools strategically.
MP.2 Reason abstractly and quantitatively. MP.6 Attend to precision.

Connections: See [G.GPE.4](#)

Common Misconceptions: See [G.GPE.4](#)

Explanations and Examples: G.GPE.7

This standard provides practice with the distance formula and its connection with the Pythagorean Theorem. Use the coordinates of the vertices of a polygon graphed in the coordinate plane and use the distance formula to compute the perimeter. Use the coordinates of the vertices of triangles and rectangles graphed in the coordinate plane to compute the area. Students may use geometric simulation software to model figures.

Examples:

- Find the perimeter and area of a rectangle with vertices at $C(-1, 1)$, $D(3, 4)$, $E(6, 0)$, $F(2, -3)$. Round your answer to the nearest hundredth when necessary.
- Find the area and perimeter for the figure below.

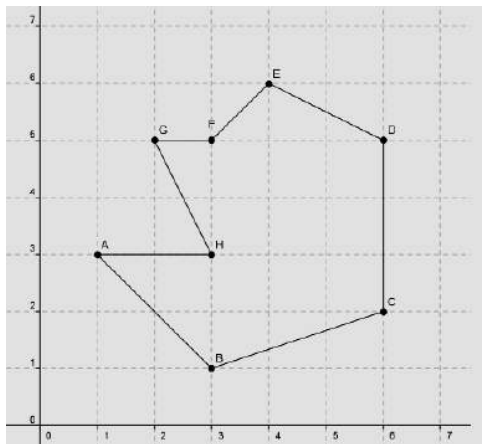

- Calculate the area of triangle ABC with altitude \overline{CD} , given $A(-4, -2)$, $B(8, 7)$, $C(1, 8)$ and $D(4, 4)$.

Continued on next page

Instructional Strategies: See [G.GPE.4](#)

Graph polygons using coordinates. Explore perimeter and area of a variety of polygons, including convex, concave, and irregularly shaped polygons.

Given a triangle, use slopes to verify that the length and height are perpendicular. Find the area.

Find the area and perimeter of a real-world shape using a coordinate grid and Google Earth. Select a shape (yard, parking lot, school, etc.). Use the tool menu to overlay a coordinate grid. Use coordinates to find the perimeter and area of the shape selected. Determine the scale factor of the picture as related to the actual real-life view. Then find the actual perimeter and area.

Geometry: Geometric Measurement and Dimensions (G-GMD)

Cluster: *Explain volume formulas and use them to solve problems.*

Standard: G.GMD.1 Give an informal argument for the formulas for the circumference of a circle, area of a circle, volume of a cylinder, pyramid, and cone. *Use dissection arguments, Cavalieri's principle, and informal limit arguments.*

Suggested Standards for Mathematical Practice (MP):

MP.3 Construct viable arguments and critique the reasoning of others. MP.4 Model with mathematics.
MP.5 Use appropriate tools strategically.

Connections: G.GMD1; G.GMD.3

In Grade 8, students were required to know and use the formulas for volumes of cylinders, cones, and spheres. In Grade 7 students informally derived the formula for the area of a circle from the circumference. In this cluster those formulas are derived by a combination of concrete demonstrations and formal reasoning.

Explanations and Examples: G.GMD.1

Informal arguments for area and volume formulas can make use of the way in which area and volume scale under similarity transformations: when one figure in the plane results from another by applying similarity transformation with scale factor k ; its area is k^2 times the area of the first. Similarly, volumes of solid figure scale k^3 under a similarity transformation with scale factor k .

Explain the formulas for the circumference of a circle and the area of circle by determining the meaning of each term or factor. Explain the formulas for the volume of a cylinder, pyramid and cone by determining the meaning of each term or factor.

Understand Cavalieri's principle - if two solids have the same height and the same cross-sectional area at every level, then they have the same volume.

Examples:

- Use the diagram to give an informal argument for the formula for finding the area of a circle. (*This concept was introduced in Grade 7*).

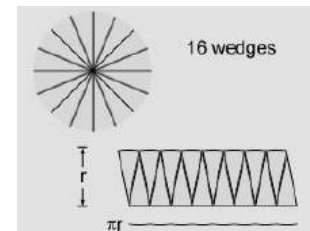

- Justify using the given measurements to find the volume of the Great Pyramid of Giza. (Dimensions shown on the diagram below are in royal cubits).

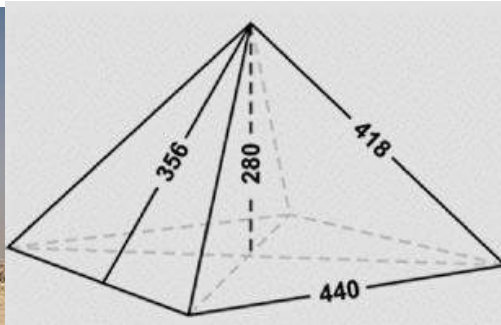

$440 \approx 755.7$ feet
$418 \approx 718$ feet
$356 \approx 611.4$ feet
$280 \approx 480.9$ feet

Continued on next page

Explanations and Examples: G.GMD.1

- Explain why the volume of a cylinder is $V = \pi r^2 h$.
- Prove that the right cylinder and the oblique cylinder have the same volume.



Instructional Strategies: G.GMD.1 & G.GMD.3

Revisit formulas $C = \pi d$ and $C = 2\pi r$. Observe that the circumference is a little more than three times the diameter of the circle. Briefly discuss the history of this number and attempts to compute its value.

Review alternative ways to derive the formula for the area of the circle $A = \pi r^2$. For example, Cut a cardboard circular disk into 6 congruent sectors and rearrange the pieces to form a shape that looks like a parallelogram with two scalloped edges. Repeat the process with 12 sectors and note how the edges of the parallelogram look “straighter.” Discuss what would happen in the case as the number of sectors becomes infinitely large. Then calculate the area of a parallelogram with base $\frac{1}{2} C$ and altitude r to derive the formula $A = \pi r^2$.

Wind a piece of string or rope to form a circular disk and cut it along a radial line. Stack the pieces to form a triangular shape with base C and altitude r . Again discuss what would happen if the string became thinner and thinner so that the number of pieces in the stack became infinitely large. Then calculate the area of the triangle to derive the formula

$$A = \pi r^2.$$

Introduce Cavalieri’s principle using a concrete model, such as a deck of cards. Use Cavalieri’s principle with cross sections of cylinders, pyramids, and cones to justify their volume formulas.

For pyramids and cones, the factor $\frac{1}{3}$ will need some explanation. An informal demonstration can be done using a volume relationship set of plastic shapes that permit one to pour liquid or sand from one shape into another. Another way to do this for pyramids is with Geoblocks. The set includes three pyramids with equal bases and altitudes that will stack to form a cube. An algebraic approach involves the formula for the sum of squares ($1^2 + 2^2 + \dots + n^2$).

After the coefficient $\frac{1}{3}$ has been justified for the formula of the volume of the pyramid ($A = \frac{1}{3}Bh$), one can argue that it must also apply to the formula of the volume of the cone by considering a cone to be a pyramid that has a base with infinitely many sides.

The formulas for volumes of cylinders, pyramids, cones and spheres can be applied to a wide variety of problems such as finding the capacity of a pipeline; comparing the amount of food in cans of various shapes; comparing capacities of cylindrical, conical and spherical storage tanks; using pyramids and cones in architecture; etc. Use a combination of concrete models and formal reasoning to develop conceptual understanding of the volume formulas.

Continued on next page

Common Misconceptions: G.GMD.1 & G.GMD.3

An informal survey of students from elementary school through college showed the number π to be the mathematical idea about which more students were curious than any other. There are at least three facets to this curiosity: the symbol π itself, the number 3.14159..., and the formula for the area of a circle. All of these facets can be addressed here, at least briefly.

Many students want to think of infinity as a number. Avoid this by talking about a quantity that becomes larger and larger with no upper bound.

The inclusion of the coefficient $\frac{1}{3}$ in the formulas for the volume of a pyramid or cone and $\frac{4}{3}$ in the formula for the volume of a sphere remains a mystery for many students. In high school, students should attain a conceptual understanding of where these coefficients come from. Concrete demonstrations, such as pouring water from one shape into another should be followed by more formal reasoning.

Geometry: Geometric Measurement and Dimensions [\(G-GMD\)](#)

Cluster: *Explain volume formulas and use them to solve problems.*

Standard: G.GMD.3 Use volume formulas for cylinders, pyramids, cones, and spheres to solve problems. (★)

Suggested Standards for Mathematical Practice (MP):

MP.1 Make sense of problems and persevere in solving them.

MP.4 Model with mathematics.

MP.2 Reason abstractly and quantitatively.

MP.5 Use appropriate tools strategically.

MP.3 Construct viable arguments and critique the reasoning of others.

Connections: See [G.GMD.1](#)

Common Misconceptions: See [G.GMD.1](#)

Explanations and Examples: G.GMD.3

Missing measures can include but are not limited to slant height, altitude, height, diagonal of a prism, edge length, and radius.

Find the volume of cylinders, pyramids, cones and spheres in contextual problems.

Examples:

- Determine the volume of the figure below.

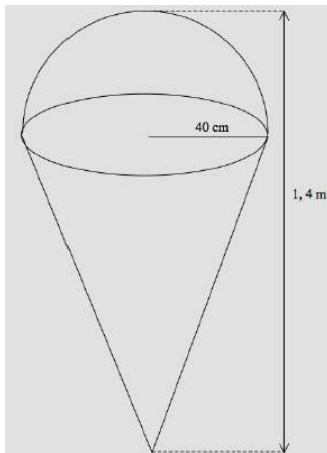

- Find the volume of a cylindrical oatmeal box.
- Given a three-dimensional object, compute the effect on volume of doubling or tripling one or more dimension(s). For example, how is the volume of a cone affected by doubling the height?

Continued on next page

Explanations and Examples: G.GMD.3

- Janine is planning on creating a water-based centerpiece for each of the 30 tables at her wedding reception. She has already purchased a cylindrical vase for each table. The radius of the vases is 6 cm. and the height is 28 cm. She intends to fill them half way with water and then add a variety of colored marbles until the waterline is approximately three-quarters of the way up the cylinder. She can buy bags of 100 marbles in 2 different sizes, with radii of 9mm or 12 mm. A bag of 9 mm marbles costs \$3, and a bag of 12 mm marbles costs \$4.
- a. If Janine only bought 9 mm marbles how much would she spend on marbles for the whole reception? What if Janine only bought 12 mm marbles? (Note: $1 \text{ cm}^3 = 1 \text{ mL}$)
 - b. Janine wants to spend at most d dollars on marbles. Write a system of equalities and/or inequalities that she can use to determine how many marbles of each type she can buy.
 - c. Based on your answer to part b. How many bags of each size marble should Janine buy if she has \$180 and wants to buy as many small marbles as possible?

Solution:

- a. We are looking to fill one fourth of the cylinder's volume with marbles, a volume given by

$$\frac{1}{4}\pi r^2 h = \frac{1}{4}\pi \cdot 6^2 \cdot 28 = 252\pi \text{ cm}^3.$$

Using the formula for the volume of the sphere, each of the 9mm (= .9cm) marbles has a volume of $\frac{4}{3}\pi(.9^3)$ or $.972\pi \text{ cm}^3$. So to fill the desired volume requires $\frac{252\pi \text{ cm}^3}{.972\pi \text{ cm}^3} \approx 260$ marbles. To obtain 260 marbles per table for each of 30 tables, Janine needs to purchase $260 \cdot 30 = 7800$ marbles. At 100 marbles per \$3-bag, this requires 78 bags of marbles, for a total cost of $3 \cdot 78 = 234$ dollars. We repeat for the 12mm marbles similarly: Each of the 12mm marbles has a volume of $\frac{4}{3}\pi(1.2)^3$ or $2.304\pi \text{ cm}^3$. To fill that volume requires $\frac{252\pi \text{ cm}^3}{2.304\pi \text{ cm}^3}$ or approximately 110 marbles. Thus 30 tables requires 3300 marbles, which in turn requires 33 bags of 12mm-marbles. At a cost of \$4 per bag, we arrive at a total cost of \$132.

- b. We have two constraints: 1) that we don't spend more than d dollars, and 2) that we acquire enough volume of marbles to fill the cylinders to their desired level (approximately a quarter of the cylinder, as in part a). Let s be the number of bags of smaller (9mm) marbles and b be the number bags of bigger (12mm) marbles.

The first constraint corresponds to the inequality

$$3 \cdot s + 4 \cdot b \leq d,$$

and the second (using calculations from part (a)) is the approximate equality

$$100 \cdot s \cdot .972\pi + 100 \cdot b \cdot 2.304\pi \approx 252\pi \cdot 30.$$

which we can re-arrange more simply as

$$97.2 \cdot s + 230.4 \cdot b \approx 7560.$$

- c. Since we learned in part (a) that it would require \$234 to do the reception entirely with small marbles, she will certainly have to spend all \$180 when maximizing the number of small marbles. Thus we can precede by solving the system of linear equations below (we have replaced approximations with equalities for the sake of solving the system, and then consider rounding below.)

$$3 \cdot s + 4 \cdot b = 180$$

$$97.2 \cdot s + 230.4 \cdot b = 7560.$$

Multiplying the top row by $\frac{97.2}{3} = 32.4$, we get

$$-97.2 \cdot s - 129.6 \cdot b = -5832$$

$$97.2 \cdot s + 230.4 \cdot b = 7560$$

Geometry: Geometric Measurement and Dimensions (G-GMD)

Cluster: *Visualize relationships between two-dimensional and three-dimensional objects.*

Standard: G.GMD.4 Identify the shapes of two-dimensional cross-sections of three-dimensional objects, and identify three-dimensional objects generated by rotations of two-dimensional objects.

Suggested Standards for Mathematical Practice (MP):

MP.4 Model with mathematics.

MP.7 Look for and make use of structure.

MP.5 Use appropriate tools strategically.

Connections:

Slices of rectangular prisms and pyramids were explored in Grade 7. In high school, the concept is extended to a wider class of solids.

Students who eventually take calculus will learn how to compute volumes of solids of revolution by a method involving cross-sectional disks.

Explanations and Examples: G.GMD.4

Given a three-dimensional object, identify the shape made when the object is cut into cross-sections.

When rotating a two-dimensional figure, such as a square, know the three-dimensional figure that is generated, such as a cylinder. Understand that a cross section of a solid is an intersection of a plane (two-dimensional) and a solid (three-dimensional).

Students may use geometric simulation software to model figures and create cross sectional views.

Examples:

- Identify the shape of the vertical, horizontal, and other cross sections of a rectangular prism.

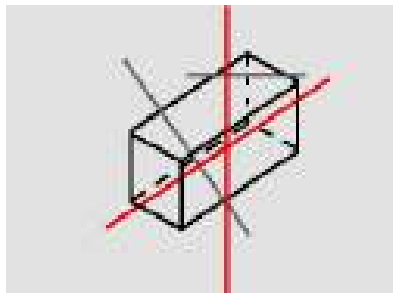

- Identify the shape of the vertical, horizontal, and other cross sections of a rectangular prism.

Continued on next page

Explanations and Examples: G.GMD.4

- The official diameter of a tennis ball, as defined by the International Tennis Federation, is at least 2.575 inches and at most 2.700 inches. Tennis balls are sold in cylindrical containers that contain three balls each. To model the container and the balls in it, we will assume that the balls are 2.7 inches in diameter and that the container is a cylinder the interior of which measures 2.7 inches in diameter and $3 \times 2.7 = 8.1$ inches high.
 - Lying on its side, the container passes through an X-ray scanner in an airport. If the material of the container is opaque to X-rays, what outline will appear? With what dimensions?
 - If the material of the container is partially opaque to X-rays and the material of the balls is completely opaque to X-rays, what will the outline look like (still assuming the can is lying on its side)?
 - The *central axis* of the container is a line that passes through the centers of the top and bottom. If one cuts the container and balls by a plane passing through the central axis, what does the intersection of the plane with the container and balls look like? (The intersection is also called a *cross section*. Imagine putting the cut surface on an ink pad and then stamping a piece of paper. The stamped image is a picture of the intersection.)
 - If the can is cut by a plane parallel to the central axis, but at a distance of 1 inch from the axis, what will the intersection of this plane with the container and balls look like?
 - If the can is cut by a plane parallel to one end of the can—a horizontal plane—what are the possible appearances of the intersections?
 - A cross-section by a horizontal plane at a height of $1.35 + w$ inches from the bottom is made, with $0 < w < 1.35$ (so the bottom ball is cut). What is the area of the portion of the cross section inside the container but outside the tennis ball?
 - Suppose the can is cut by a plane parallel to the central axis but at a distance of w inches from the axis ($0 < w < 1.35$). What fractional part of the cross section of the container is inside of a tennis ball?

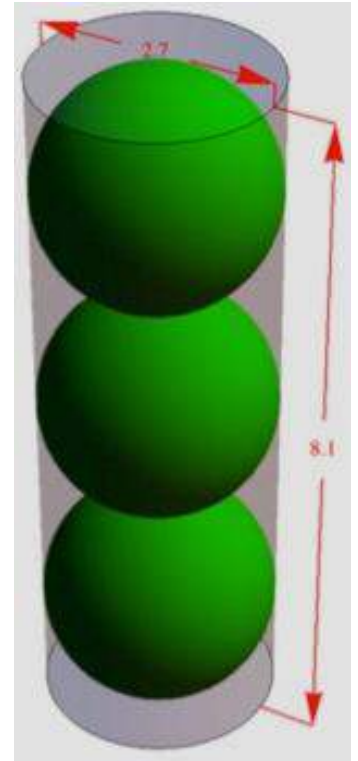

Solution: (This task connects with domain G.MG)

- The shadow is a rectangle measuring 2.7 inches by 8.1 inches.
- The shadow is a light rectangle (2.7×8.1 inches) with three disks inside. It looks like a traffic light:

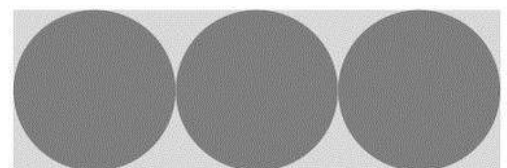

- The image is similar to the previous one, but now only the outlines are seen:

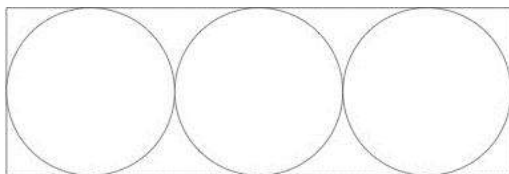

Continued on next page

Explanations and Examples: G.GMD.4

d. The intersection with the container is a narrower rectangle. The intersections with the balls are smaller circles. Because each ball touches the container along its whole “equator,” the circles must touch the long sides of the rectangle:

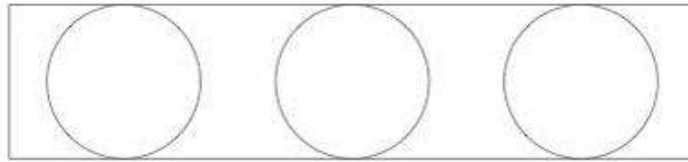

e. The intersections are two concentric circles, except when $w = 0, 2.7, 5.4, 8.1$ and when $w = 1.35, 4.05, 6.75$. In the former case, we see a circle (from the container) and a point (where the plane touches a sphere). In the latter case, we see a single circle corresponding to a place where the equator of a ball touches the container.

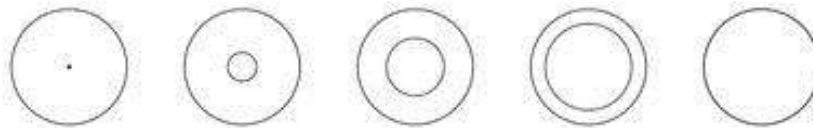

f. The intersection of the plane with the interior of the *container* is a disk of radius 1.35 inches. Its area is $\pi(1.35)^2 \text{in}^2$. The intersection with the *ball* is a smaller disk that is contained in the first disk. The radius r of the smaller disk is the square root of $(1.35)^2 - w^2$, as we see from the diagram below depicting the intersection of a plane through the central axis of the container with the bottom ball. Thus, the area of the smaller disk is $\pi((1.35)^2 - w^2)$. Accordingly, the area inside the larger disk but outside the smaller is πw^2 , provided that $0 \leq w \leq 1.35$. (It is notable that the radius of the ball does not appear explicitly in the expression for this annular area.)

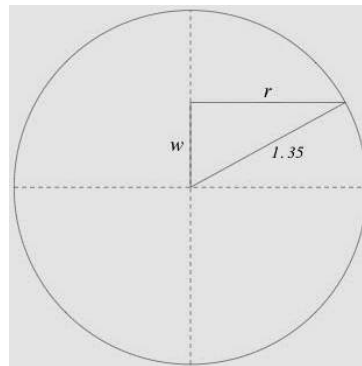

g. Referring to Problem d), we see that we wish to find the ratio of the total area of three congruent disks to the area of a rectangle, one of whose dimensions is equal to the diameter of the disks. The same picture used in the previous problem, but interpreted as a view from one end of the container, gives us the radius of the small disks — namely, $\sqrt{(1.35)^2 - w^2}$, so the total area of the disks is $3\pi((1.35)^2 - w^2)$.

The area of the rectangle is $(8.1)2\sqrt{(1.35)^2 - w^2}$. So, the ratio is

$$\frac{3\pi((1.35)^2 - w^2)}{(8.1)2\sqrt{(1.35)^2 - w^2}} = \frac{\pi\sqrt{(1.35)^2 - w^2}}{5.4}$$

Continued on next page

Instructional Strategies: G.GMD.4

Review vocabulary for names of solids (e.g., right prism, cylinder, cone, sphere, etc.).

Slice various solids to illustrate their cross sections. For example, cross sections of a cube can be triangles, quadrilaterals or hexagons. Rubber bands may also be stretched around a solid to show a cross section.

Cut a half-inch slit in the end of a drinking straw, and insert a cardboard cutout shape. Rotate the straw and observe the three-dimensional solid of revolution generated by the two-dimensional cutout.

Java applets on some web sites can also be used to illustrate cross sections or solids of revolution.

Encourage students to create three-dimensional models to be sliced and cardboard cutouts to be rotated. Students can also make three-dimensional models out of modeling clay and slice through them with a plastic knife.

Common Misconceptions: G.GMD.4

Some cross sections are more difficult to visualize than others. For example, it is often easier to visualize a rectangular cross section of a cube than a hexagonal cross section.

Generating solids of revolution involves motion and is difficult to visualize by merely looking at drawings.

Geometry: Modeling with Geometry [\(G-MG\)](#)

Cluster: *Apply geometric concepts in modeling situations.*

Standard: G.MG.1 Use geometric shapes, their measures, and their properties to describe objects (e.g., modeling a tree trunk or a human torso as a cylinder). (★)

Suggested Standards for Mathematical Practice (MP):

MP.4 Model with mathematics.

MP.7 Look for and make use of structure.

MP.5 Use appropriate tools strategically.

Connections: G.MG.1-3

Modeling activities are a good way to show connections among various branches of mathematics.

Explanations and Examples: G.MG.1

Focus on situations that require relating two- and three- dimensional objects.

Estimate measures (circumference, area, perimeter, volume) of real-world objects using comparable geometric shapes or three-dimensional objects.

Apply the properties of geometric figures to comparable real-world objects (e.g., The spokes of a wheel of a bicycle are equal lengths because they represent the radii of a circle).

Students may use simulation software and modeling software to explore which model best describes a set of data or situation.

Examples:

- How can you model objects in your classroom as geometric shapes?
- Picture a roll of toilet paper; assume that the paper in the roll is very tightly rolled. Assuming that the paper in the roll is very thin, find a relationship between the thickness of the paper, the inner and outer radii of the roll, and the length of the paper in the roll.

Express your answer as an algebraic formula involving the four listed variables.

The purpose of this task is to engage students in geometric modeling, and in particular to deduce algebraic relationships between variables stemming from geometric constraints. The modeling process is a challenging one, and will likely elicit a variety of attempts from the students. Teachers should expect to spend time guiding students away from overly complicated models. Similarly, the task presents one solution, but alternatives abound: For example, students could imagine slicing the roll along a radius, unraveling the cross-section into a sequence of trapezoids whose area can be computed.

Continued on next page

Explanations and Examples: G.MG.1

Solution:

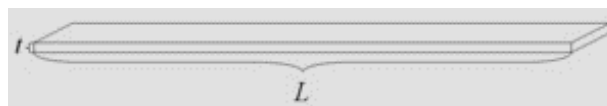
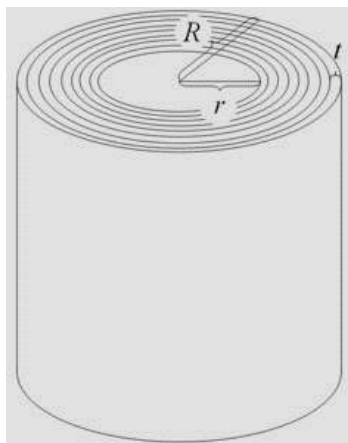

We begin by labeling the variables, for which the above diagrams may be useful. Let t denote the thickness of the paper, let r denote the inner radius, let R denote the outer radius and let L denote the length of the paper, all measured in inches. We now consider the area A , measured in square inches, of the annular cross-section displayed at the top of the first image, consisting of concentric circles. Namely, we see that this area can be expressed in two ways: First, since this area is the area of the circle of radius R minus the area of the circle of radius r , we learn that $A = \pi(R^2 - r^2)$.

Second, if the paper were unrolled, laid on a (very long) table and viewed from the side, we would see a very long thin rectangle. When the paper is rolled up, this rectangle is distorted, but -- assuming r is large in comparison to t -- the area of the distorted rectangle is nearly identical to that of the flat one. As in the second figure, the formula for the area of a rectangle now gives $A = t \cdot L$.

Comparing the two formulas for A , we find that the four variables are related by: $t \cdot L = \pi(R^2 - r^2)$.

Instructional Strategies: G.MG.1-3

Genuine mathematical modeling typically involves more than one conceptual category. For example, modeling a herd of wild animals may involve geometry, measurement, proportional reasoning, estimation, probability and statistics, functions, and algebra. It would be somewhat misleading to try to teach a unit with the title of "modeling with geometry." Instead, these standards can be woven into other content clusters.

A challenge for teaching modeling is finding problems that are interesting and relevant to high school students and, at the same time, solvable with the mathematical tools at the students' disposal. The resources listed below are a beginning for addressing this difficulty.

Common Misconceptions: G.MG.1-3

When students ask to see "useful" mathematics, what they often mean is, "Show me how to use this mathematical concept or skill to solve the homework problems." Mathematical modeling, on the other hand, involves solving problems in which the path to the solution is not obvious. Geometry may be one of several tools that can be used.

Geometry: Modeling with Geometry [\(G-MG\)](#)

Cluster: *Apply geometric concepts in modeling situations.* (★)

Standard: G.MG.2 Apply concepts of density based on area and volume in modeling situations (e.g., persons per square mile, BTUs per cubic foot). (★)

Suggested Standards for Mathematical Practice (MP):

MP.1 Make sense of problems and persevere in solving them. MP.4 Model with mathematics.
MP.5 Use appropriate tools strategically.

Connections: See [G.MG.1](#)

Common Misconceptions: See [G.MG.1](#)

Explanations and Examples: G.MG.1

Decide whether it is best to calculate or estimate the area or volume of a geometric figure and perform the calculation or estimation.

Students may use simulation software and modeling software to explore which model best describes a set of data or situation.

Examples:

- Wichita, Kansas has 344,234 people within 165.9 square miles. What is Wichita’s population density?
- Consider the two boxes below. Each box has the same volume. If each ball has the same mass, which box would weigh more? Why

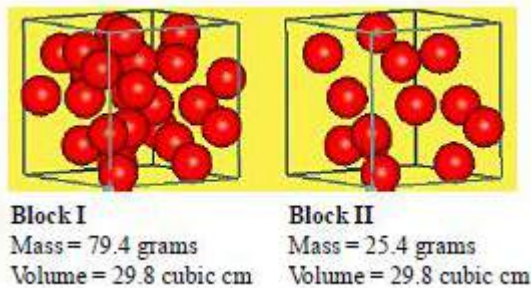

- A King Size waterbed has the following dimensions 72 in. X 84 in. X 9.5in. It takes 240.7 gallons of water to fill it which would weigh 2071 pounds. What is the weight of a cubic foot of water?

Instructional Strategies: See [G.MG.1](#)

Geometry: Modeling with Geometry ([G-MG](#))

Cluster: *Apply geometric concepts in modeling situations.*

Standard: G.MG.3 Apply geometric methods to solve design problems (e.g., designing an object or structure to satisfy physical constraints or minimize cost; working with typographic grid systems based on ratios). (★)

Suggested Standards for Mathematical Practice (MP):

MP.1 Make sense of problems and persevere in solving them. MP.4 Model with mathematics.
MP.5 Use appropriate tools strategically.

Connections: See [G.MG.1](#)

Common Misconceptions: See [G.MG.1](#)

Explanations and Examples: G.MG.3

Create a visual representation of a design problem and solve using a geometric model (graph, equation, table, formula).

Interpret the results and make conclusions based on the geometric model.

Students may use simulation software and modeling software to explore which model best describes a set of data or situation.

Examples:

- Given one geometric solid, design a different geometric solid that will hold the same amount of substance (e.g., a cone to a prism).
- This paper clip is just over 4 cm long.

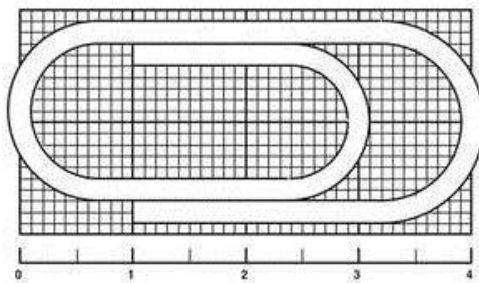

How many paper clips like this may be made from a straight piece of wire 10 meters long?

In this task, a typographic grid system serves as the background for a standard paper clip. A metric measurement scale is drawn across the bottom of the grid and the paper clip extends in both directions slightly beyond the grid. Students are given the approximate length of the paper clip and determine the number of like paper clips made from a given length of wire. Extending the paper clip beyond the grid provides an opportunity to include an estimation component in the problem. In the interest of open-ended problem solving, no scaffolding or additional questions are posed in this task. The paper clip modeled in this problem is an actual large standard paper clip.

Explanations and Examples: G.MG.3

Sample Response:

One approach is to divide the paper clip into vertical regions, and then to use the measurement grid to determine the length of the straight sections and estimate the length of the curved sections using a string or thin wire in conjunction with the measurement scale provided. One such division is accomplished using three vertical dividers splitting the paper clip into four distinct regions as shown.

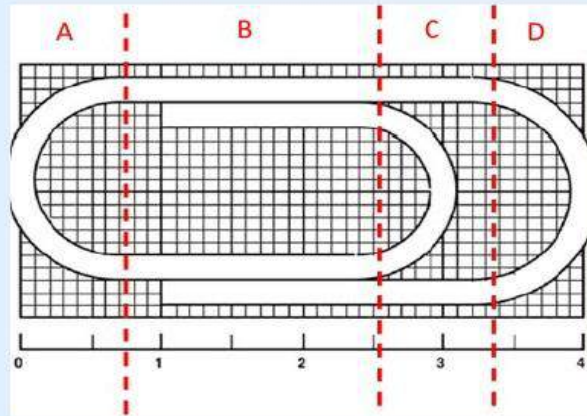

Regions	Number of Linear Sections	Number of Curved Sections
Region A	0	1
Region B	4	0
Region C	2	1
Region D	0	1

The lengths of the linear sections were determined using the gridlines. The estimations of the lengths of the curved sections were determined using a string or thin wire in conjunction with the measurement scale provided.

Regions	Measurement of Linear Sections (listed from top to bottom)	Estimated Measurement of Curved Sections
Region A		2.5cm
Region B	1.8cm, 1.5cm, 1.8cm, 1.5cm	
Region C	0.8cm, 0.8cm	1.6cm
Region D		2.5cm

The length of wire needed to manufacture one paper clip is now approximately:

$$1.8 \text{ cm} + 1.5 \text{ cm} + 1.8 \text{ cm} + 1.5 \text{ cm} + 0.8 \text{ cm} + 0.8 \text{ cm} + 2.5 \text{ cm} + 1.6 \text{ cm} + 2.5 \text{ cm} = 14.8 \text{ cm}$$

The length of the straight piece of wire is 10 meters. Since 1 meter is the same as 100 centimeters, 10 meters is $10 \cdot 100 = 1000$ centimeters. Finally, we find that at 14.8 cm per paper clip, 1000 centimeters will produce approximately

$$\frac{1000}{14.8} \approx 67.6 \text{ paper clips.}$$

Since we can only make a whole number of paper clips, we conclude that approximately 67 paper clips may be manufactured from a straight piece of wire 10 meters in length.

Instructional Strategies: See [G.MG.1](#)

Conceptual Category Statistics and Probability (★)

Decisions or predictions are often based on data—numbers in context. These decisions or predictions would be easy if the data always sent a clear message, but the message is often obscured by variability. Statistics provides tools for describing variability in data and for making informed decisions that take it into account.

Data are gathered, displayed, summarized, examined, and interpreted to discover patterns and deviations from patterns. Quantitative data can be described in terms of key characteristics: measures of shape, center, and spread. The shape of a data distribution might be described as symmetric, skewed, flat, or bell shaped, and it might be summarized by a statistic measuring center (such as mean or median) and a statistic measuring spread (such as standard deviation or interquartile range). Different distributions can be compared numerically using these statistics or compared visually using plots. Knowledge of center and spread are not enough to describe a distribution. Which statistics to compare, which plots to use, and what the results of a comparison might mean, depend on the question to be investigated and the real-life actions to be taken.

Randomization has two important uses in drawing statistical conclusions. First, collecting data from a random sample of a population makes it possible to draw valid conclusions about the whole population, taking variability into account. Second, randomly assigning individuals to different treatments allows a fair comparison of the effectiveness of those treatments. A statistically significant outcome is one that is unlikely to be due to chance alone, and this can be evaluated only under the condition of randomness. The conditions under which data are collected are important in drawing conclusions from the data; in critically reviewing uses of statistics in public media and other reports, it is important to consider the study design, how the data were gathered, and the analyses employed as well as the data summaries and the conclusions drawn.

Random processes can be described mathematically by using a probability model: a list or description of the possible outcomes (the sample space), each of which is assigned a probability. In situations such as flipping a coin, rolling a number cube, or drawing a card, it might be reasonable to assume various outcomes are equally likely. In a probability model, sample points represent outcomes and combine to make up events; probabilities of events can be computed by applying the Addition and Multiplication Rules. Interpreting these probabilities relies on an understanding of independence and conditional probability, which can be approached through the analysis of two-way tables.

Technology plays an important role in statistics and probability by making it possible to generate plots, regression functions, and correlation coefficients, and to simulate many possible outcomes in a short amount of time.

Connections to Functions and Modeling. Functions may be used to describe data; if the data suggest a linear relationship, the relationship can be modeled with a regression line, and its strength and direction can be expressed through a correlation coefficient.

Statistics and Probability Standards Overview

Note: The standards identified with a (+) contain additional mathematics that students should learn in order to take advanced courses such as calculus, advanced statistics or discrete mathematics that go beyond the mathematics that all students should study in order to be college- and career-ready. Explanations and examples of these standards are not included in this document.

Modeling Standards: All standards within the Statistics and Probability conceptual category are specified as modeling standards. (★) [\(RETURN TO PG.5\)](#)

Interpreting Categorical and Quantitative Data (★) (S-ID)

- *Summarize, represent, and interpret data on a single count or measurement variable.*
[S.ID.1](#) [S.ID.2](#) [S.ID.3](#) [S.ID.4](#)
- *Summarize, represent, and interpret data on two categorical and quantitative variables.*
[S.ID.5](#) [S.ID.6](#)
- *Interpret linear models.*
[S.ID.7](#) [S.ID.8](#) [S.ID.9](#)

Making Inferences and Justifying Conclusions (★) (S-IC)

- *Understand and evaluate random processes underlying statistical experiments..*
[S.IC.1](#) [S.IC.2](#)
- *Make inferences and justify conclusions from sample surveys, experiments, and observational studies.*
[S.IC.3](#) [S.IC.4](#) [S.IC.5](#) [S.IC.6](#)

Conditional Probability and the Rules of Probability (★) (S-CP)

- *Understand independence and conditional probability and use them to interpret data..*
[S.CP.1](#) [S.CP.2](#) [S.CP.3](#) [S.CP.4](#) [S.CP.5](#)
- *Use the rules of probability to compute probabilities of compound events in a uniform probability model.*
[S.CP.6](#) [S.CP.7](#) S.CP.8 (+) S.CP.9 (+)

Using Probability to Make Decisions (+) (★) (S-MD)

The standards in this domain go beyond the mathematics that all students should study in order to be college- and career-ready. The clusters and standards listed are not included in this document.

- *Calculate expected values and use them to solve problems.*
S.MD.1 (+) S.MD.2 (+) S.MD.3 (+) S.MD.4 (+)
- *Use probability to evaluate outcomes of decisions.*
S.MD.5 (+) S.MD.6 (+) S.MD.7 (+)

Statistics and Probability: Interpreting Categorical and Quantitative Data ★ [\(S-ID\)](#)

Cluster: *Summarize, represent, and interpret data on a single count or measurement variable.*

Standard: S.ID.1 Represent data with plots on the real number line (dot plots, histograms, and box plots). (★)

Suggested Standards for Mathematical Practice (MP):

MP.1 Make sense of problems and persevere in solving them. MP.4 Model with mathematics.
MP.5 Use appropriate tools strategically.

Connections: S.ID.1-4

The four-step statistical process was introduced in Grade 6, with the recognition of statistical questions. In middle school students describe center and spread in a data distribution. At the high school level, students need to become proficient in the first step of generating meaningful questions and choose a summary statistic appropriate to the characteristic of the data distribution, such as the shape of the distribution or the existence of extreme data points.

Explanations and Examples: S.ID.1

A statistical process is a problem-solving process consisting of four steps:

1. formulating a statistical question that anticipates variability and can be answered by data
2. designing and implementing a plan that collects appropriate data.
3. analyzing the data by graphical and/or numerical methods.
4. interpreting the analysis in the context of the original question.

Graph numerical data on a real number line using dot plots, histograms, and box plots.

Analyze the strengths and weakness inherent in each type of plot by comparing different plots of the same data. Describe and give a simple interpretation of a graphical representation of data.

Examples:

- The following data set shows the number of songs downloaded in one week by each student in Mrs. Jones class: 10, 20, 12, 14, 12, 27, 88, 2, 7, 30, 16, 16, 32, 25, 15, 4, 0, 15, 6.

Choose and create a plot to represent the data.

- On the midterm math exam, students had the following scores: 95, 45, 37, 82, 90, 100, 91, 78, 67, 84, 85, 85, 82, 91, 93, 92, 76, 84, 100, 59, 92, 77, 68, and 88.

What are the strengths and weaknesses of presenting this data in a certain type of plot for:

- Students in a class?
- Parents?
- The school board?

Continued on next page

Explanations and Examples: S.ID.1

- A movie theater recorded the number of tickets sold for two movies each day during one week. Box plots of the data are shown below.

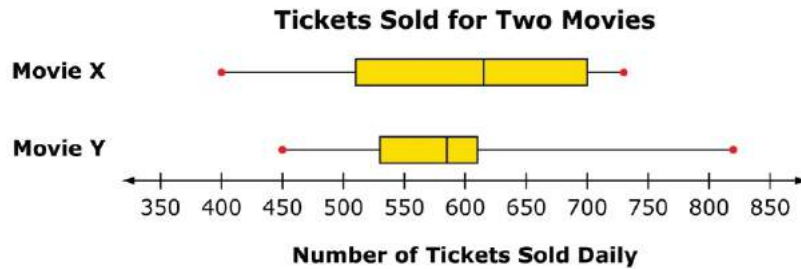

Based on the box plot, determine whether each of the following statements is true, false, or cannot be determined from the information given in the box plot.

	True	False	Cannot Be Determined
The mean number of tickets sold for Movie X is greater than the mean number of tickets sold for Movie Y.	<input type="radio"/>	<input type="radio"/>	<input type="radio"/>
The median number of tickets sold for Movie X is greater than the mean number of tickets sold for Movie Y.	<input type="radio"/>	<input type="radio"/>	<input type="radio"/>
The interquartile range of the number of tickets sold for Movie X is greater than the interquartile range of the number of tickets sold for Movie Y.	<input type="radio"/>	<input type="radio"/>	<input type="radio"/>

Solution: Row 1: Cannot be determined; Row 2: True; Row 3: True

Instructional Strategies: S.ID.1-4

It is helpful for students to understand that a statistical process is a problem-solving process consisting of four steps. Opportunities should be provided for students to work through the statistical process. In Grades 6-8, learning has focused on parts of this process. Now is a good time to investigate a problem of interest to the students and follow it through. The richer the question formulated, the more interesting is the process. Teachers and students should make extensive use of resources to perfect this very important first step. Global web resources can inspire projects.

Help students to clearly distinguish between categorical and numerical variables by providing multiple examples of each type.

Some students may need to begin with “well-behaved” data sets. As they progress in their understanding and work with data, begin to include data sets with outliers and non-Normal shapes.

Although this domain addresses both categorical and quantitative data, there is no reference in the Standards 1 - 4 to categorical data. Note that Standard 5 in the next cluster (Summarize, represent, and interpret data on two categorical and quantitative variables) addresses analysis for two categorical variables on the same subject.

To prepare for interpreting two categorical variables in Standard 5, this would be a good place to discuss graphs for one categorical variable (bar graph, pie graph) and measure of center (mode).

Continued on next page

Instructional Strategies: S.ID.1-4

Have students practice their understanding of the different types of graphs for categorical and numerical variables by constructing statistical posters. Note that a bar graph for categorical data may have frequency on the vertical (student's pizza preferences) or measurement on the vertical (radish root growth over time - days).

Measures of center and spread for data sets without outliers are the mean and standard deviation, whereas median and interquartile range are better measures for data sets with outliers.

Introduce the formula of standard deviation by reviewing the previously learned MAD (mean absolute deviation). The MAD is very intuitive and gives a solid foundation for developing the more complicated standard deviation measure.

Informally observing the extent to which two boxplots or two dot plots overlap begins the discussion of drawing inferential conclusions. Don't shortcut this observation in comparing two data sets.

As histograms for various data sets are drawn, common shapes appear. To characterize the shapes, curves are sketched through the midpoints of the tops of the histogram's rectangles. Of particular importance is a symmetric unimodal curve that has specific areas within one, two, and three standard deviations of its mean. It is called the Normal distribution and students need to be able to find areas (probabilities) for various events using tables or a graphing calculator.

Common Misconceptions: S.ID.1-4

Students may believe:

That a bar graph and a histogram are the same. A bar graph is appropriate when the horizontal axis has categories and the vertical axis is labeled by either frequency (e.g., book titles on the horizontal and number of students who like the respective books on the vertical) or measurement of some numerical variable (e.g., days of the week on the horizontal and median length of root growth of radish seeds on the vertical). A histogram has units of measurement of a numerical variable on the horizontal (e.g., ages with intervals of equal length).

That the lengths of the intervals of a boxplot (min,Q1), (Q1,Q2), (Q2,Q3), (Q3,max) are related to the number of subjects in each interval. Students should understand that each interval theoretically contains one-fourth of the total number of subjects. Sketching an accompanying histogram and constructing a live boxplot may help in alleviating this misconception.

That all bell-shaped curves are normal distributions. For a bell-shaped curve to be Normal, there needs to be 68% of the distribution within one standard deviation of the mean, 95% within two, and 99.7% within three standard deviations.

Statistics and Probability: Interpreting Categorical and Quantitative Data ★ [\(S-ID\)](#)

Cluster: *Summarize, represent, and interpret data on a single count or measurement variable.*

Standard: S.ID.2 Use statistics appropriate to the shape of the data distribution to compare center (median, mean) and spread (interquartile range, standard deviation) of two or more different data sets. (★)

Suggested Standards for Mathematical Practice (MP):

MP.1 Make sense of problems and persevere in solving them. MP.5 Use appropriate tools strategically.
MP.2 Reason abstractly and quantitatively. MP.7 Look for and make use of structure.
MP.3 Construct viable arguments and critique the reasoning of others.
MP.4 Model with mathematics.

Connections: See [S.ID.1](#)

Common Misconceptions: See [S.ID.1](#)

Explanations and Examples: S.ID.2

Given two sets of data or two graphs, identify the similarities and differences in shape, center and spread. Compare data sets and be able to summarize the similarities and difference between the shape, and measures of center and spreads of the data sets.

Use the correct measure of center and spread to describe a distribution that is symmetric or skewed. Identify outliers and their effects on data sets.

Students may use spreadsheets, graphing calculators and statistical software for calculations, summaries, and comparisons of data sets.

Examples:

- The box plots show the distribution of scores on a district writing test of two classes at a school. Compare the range and medians of the scores form the two classes.

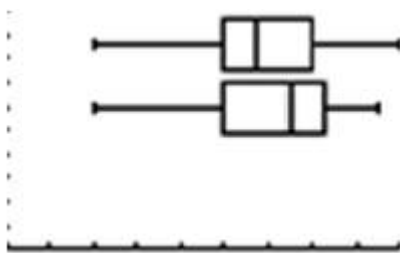

- Given a set of test scores: 99, 96, 94, 93, 90, 88, 86, 77, 70, 68, find the mean, median, and standard deviation. Explain how the values vary about the mean and median. What information does this give the teacher?

Continued on next page

Explanations and Examples: S.ID.2

- The frequency distributions of two data sets are shown in the dot plots below.

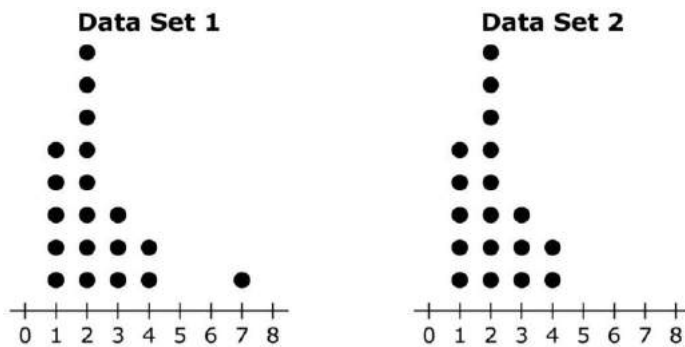

For each of the following statistics, determine whether the value of the statistic is greater for Data Set 1, equal for both data sets, or greater for Data Set 2.

	Greater for Data Set 1	Equal for Both Data Sets	Greater for Data Set 2
Mean			
Median			
Standard Deviation			

Solution:

- Row 1: Greater for Data Set 1
- Row 2: Equal for both data sets
- Row 3: Greater for Data Set 1

Instructional Strategies: See [S.ID.1](#)

Statistics and Probability: Interpreting Categorical and Quantitative Data ★ [\(S-ID\)](#)

Cluster: *Summarize, represent, and interpret data on a single count or measurement variable.*

Standard: S.ID.3 Interpret differences in shape, center, and spread in the context of the data sets, accounting for possible effects of extreme data points (outliers). (★)

Suggested Standards for Mathematical Practice (MP):

- MP.1 Make sense of problems and persevere in solving them. MP.5 Use appropriate tools strategically.
MP.2 Reason abstractly and quantitatively. MP.7 Look for and make use of structure.
MP.3 Construct viable arguments and critique the reasoning of others.
MP.4 Model with mathematics.

Connections: See [S.ID.1](#)

Common Misconceptions: See [S.ID.1](#)

Explanations and Examples: S.ID.3

Use data from multiple sources to interpret differences in shape, center and spread.
Discuss the effect of outliers on measures of center and spread and the effect on the shape.
Predict the effect an outlier will have on the shape, center, and spread of a data set.
Decide whether to include the outliers as part of the data set or to remove them.

Students may use spreadsheets, graphing calculators and statistical software to statistically identify outliers and analyze data sets with and without outliers as appropriate.

Examples:

- The box plots show the distribution of scores on a district writing test of two classes at a school. Which class performed better? Justify your conclusion.

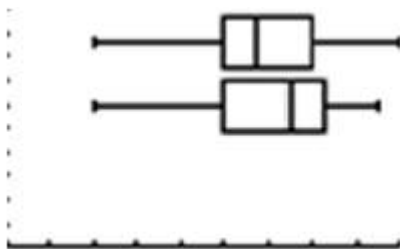

- Find two similar data sets A and B. Choose and create a plot or graph to represent the data. What changes would need to be made to data set A to make it look like data set B?

Continued on next page

Explanations and Examples: S.ID.3

- The ages of the students in a certain high school are to be graphed on a set of parallel box plots according to the following:

Set I: All seniors in the school (grade 12)

Set II: All students in the school (grades 9 through 12)

In the figure below, drag each of the two box plots into position above the number line to approximate the ages of the two sets of students. To do this:

- First move each box plot at an appropriate location according to its center.
- Then drag each endpoint to stretch the box plot to represent the spread.

Note: There are no outliers in either set.

I. Seniors Only

II. All Students

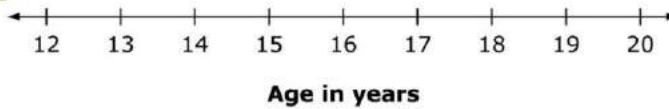

Solution:

I. Seniors Only



II. All Students

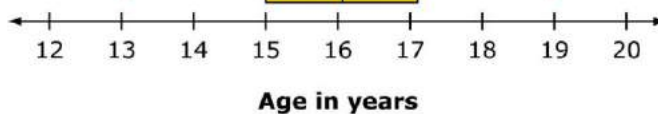

Graphs should show: Median of I > Median of II Range of I < Range of II Max of I ≤ Max of II

- The dot plots below compare the number of minutes 30 flights made by two airlines arrived before or after their scheduled arrival times.

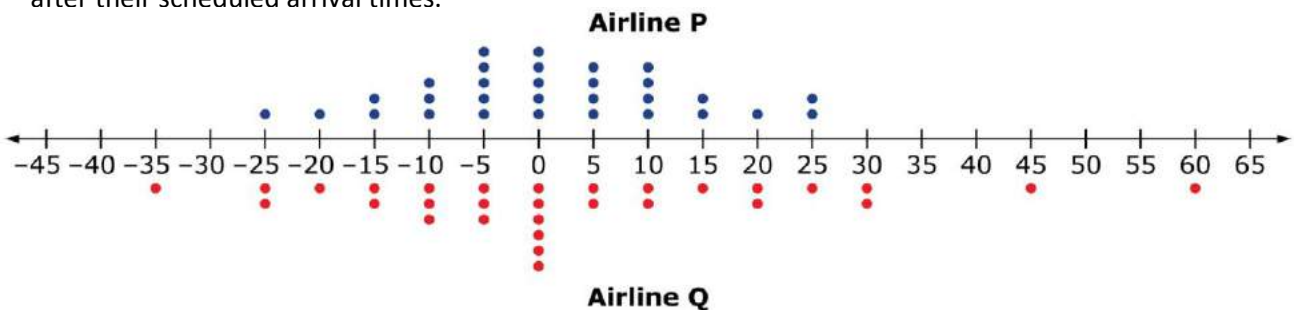

- Negative numbers represent the minutes the flight arrived **before** its scheduled time.
- Positive numbers represent the minutes the flight arrived **after** its scheduled time.
- Zero indicates the flight arrived **at** its scheduled time.

Based on these data, from which airline will you choose to buy your ticket?
Use the ideas of center and spread to justify your choice.

Continued on next page

Explanations and Examples: S.ID.3

Sample Response:

I would choose to buy the ticket from Airline P. Both airlines are likely to have an on-time arrival since they both have median values at 0. However, Airline Q has a much greater range in arrival times. Airline Q could arrive anywhere from 35 minutes early to 60 minutes late. For Airline P, this flight arrived within 10 minutes on either side of the scheduled arrival time about $\frac{2}{3}$ of the time, and for Airline Q, that number was only about $\frac{1}{2}$. For these reasons, I think Airline P is the better choice.

Instructional Strategies: See [S.ID.1](#)

Statistics and Probability: Interpreting Categorical and Quantitative Data ★ [\(S-ID\)](#)

Cluster: *Summarize, represent, and interpret data on a single count or measurement variable.*

Standard: S.ID.4 Use the mean and standard deviation of a data set to fit it to a normal distribution and to estimate population percentages. Recognize that there are data sets for which such a procedure is not appropriate. Use calculators, spreadsheets, and tables to estimate areas under the normal curve. (★)

Suggested Standards for Mathematical Practice (MP):

- MP.1 Make sense of problems and persevere in solving them. MP.5 Use appropriate tools strategically.
MP.2 Reason abstractly and quantitatively. MP.7 Look for and make use of structure.
MP.3 Construct viable arguments and critique the reasoning of others.
MP.4 Model with mathematics.

Connections: See [S.ID.1](#)

Common Misconceptions: See [S.ID.1](#)

Explanations and Examples: S.ID.4

While students may have heard of the normal distribution, they may have little prior experience using it to make specific estimates. Build on students' understanding of data distributions to help them see how the normal distribution uses are to make estimates of frequencies (which can be expressed as probabilities).

Emphasize that only some data are well described by a normal distribution.

Use the 68-95-99.7 rule to estimate the percent of a normal population that falls within 1, 2, or 3 standard deviations of the mean.

Recognize that normal distributions are only appropriate for unimodal and symmetric shapes.

Students may use spreadsheets, graphing calculators and statistical software, and tables to analyze the fit between a data set and normal distributions and estimate areas under the curve.

Examples:

- The bar graph below gives the birth weight of a population of 100 chimpanzees. The line shows how the weights are normally distributed about the mean, 3250 grams. Estimate the percent of baby chimps weighing 3000–3999 grams.

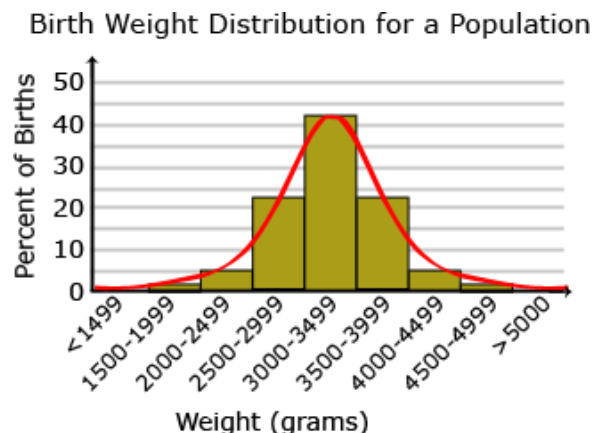

Continued on next page

Explanations and Examples: S.ID.4

- Determine which situation(s) is best modeled by a normal distribution. Explain your reasoning.
 - Annual income of a household in the U.S.
 - Weight of babies born in one year in the U.S.

- Suppose that SAT mathematics scores for a particular year are approximately normally distributed with a mean of 510 and a standard deviation of 100.
 1. What is the probability that a randomly selected score is greater than 610?
 2. Greater than 710?
 3. Between 410 and 710?
 4. If a student is known to score 750, what is the student's percentile score (the proportion of scores below 750)?

Solution:

1. The score 610 is one standard deviation above the mean, so the tail area above that is about half of 0.32 or 0.16. The calculator gives 0.1586.
2. The score 710 is two standard deviations above the mean, so the tail area above that is about half of 0.05 or 0.025. The calculator gives 0.0227.
3. The area under a normal curve from one standard deviation below the mean to two standard deviations above is about 0.815. The calculator gives 0.8186.
4. Either using the normal distribution given or the standard normal (for which 750 translates to a z-score of 2.4) the calculator gives 0.9918.

Instructional Strategies: See [S.ID.1](#)

Explanations and Examples: S.ID.5

Two-way Relative Frequency Table

- The relative frequencies in the body of the table are called conditional relative frequencies.

Bald	Age		Total
	Younger than 45	45 or older	
No	0.35	0.11	0.46
Yes	0.24	0.30	0.54
Total	0.59	0.41	1.00

- Given the data in the table below, what is the joint frequency of students who have chores and a curfew? Which marginal frequency is the largest?

	Curfew: Yes	Curfew: No	Total
Chores: Yes	13	5	18
Chores: No	12	3	15
Total	25	8	

- The 54 students in one of several middle school classrooms were asked two questions about musical preferences: “Do you like rock?” “Do you like rap?” The responses are summarized in the table below.

Like Rock	Like Rap		Row Totals
	Yes	No	
Yes	27	6	33
No	4	17	21
Column Totals	31	23	54

- Is this a random sample, one that fairly represents the opinions of all students in the middle school?
- What percentage of the students in the classroom like rock?
- Is there evidence in this sample of a positive association in this class between liking rock and liking rap? Justify your answer by pointing out a feature of the table that supports it.
- Explain why the results for this classroom might not generalize to the entire middle school.

Solution:

- This is not a randomly selected sample that fairly represents the students in the school. See part (d) for more details.
- $\frac{33}{54} = 61.1\%$
- Yes, there is evidence of a positive association. Of those who like Rap, $\frac{27}{31} = 87.1\%$ like Rock, too. This means that the percentage of those who like Rock is higher among those who like Rap than among the entire sample.
- The sample is not necessarily a random sample. While it might be true that the association holds in other classes, we have no evidence of this. It is possible, for instance, that this was an unusual class at this school; maybe this class consisted entirely of music students, and their preferences would be different than in other classes or than in the entire school.

Continued on next page

Instructional Strategies: S.ID.5-6

In the categorical case, begin with two categories for each variable and represent them in a two-way table with the two values of one variable defining the rows and the two values of the other variable defining the columns. (Extending the number of rows and columns is easily done once students become comfortable with the 2x2 case.) The table entries are the joint frequencies of how many subjects displayed the respective cross-classified values. Row totals and column totals constitute the marginal frequencies. Dividing joint or marginal frequencies by the total number of subjects define relative frequencies (and percentages), respectively. Conditional relative frequencies are determined by focusing on a specific row or column of the table. They are particularly useful in determining any associations between the two variables.

In the numerical or quantitative case, display the paired data in a scatterplot. Note that although the two variables in general will not have the same scale, e.g., total SAT versus grade-point average, it is best to begin with variables with the same scale such as SAT Verbal and SAT Math. Fitting functions to such data will avoid difficulties such as interpretation of slope in the linear case in which scales differ. Once students are comfortable with the same scale case, introducing different scales situations will be less problematic.

Common Misconceptions: S.ID.5-6

Students may believe:

That a 45 degree line in the scatterplot of two numerical variables always indicates a slope of 1 which is the case only when the two variables have the same scaling.

That residual plots in the quantitative case should show a pattern of some sort. Just the opposite is the case.

Statistics and Probability: Interpreting Categorical and Quantitative Data ★ [\(S-ID\)](#)

Cluster: *Summarize, represent, and interpret data on two categorical and quantitative variables.*

Standard: S.ID.6 Represent data on two quantitative variables on a scatter plot, and describe how the variables are related. (★)

- Fit a function to the data; use functions fitted to data to solve problems in the context of the data. *Use given functions or choose a function suggested by the context. Emphasize linear and exponential models.*
- Informally assess the fit of a function by plotting and analyzing residuals.
- Fit a linear function for a scatter plot that suggests a linear association.

Suggested Standards for Mathematical Practice (MP):

MP.2 Reason abstractly and quantitatively. MP.7 Look for and make use of structure.
MP.3 Construct viable arguments and critique the reasoning of others.
MP.4 Model with mathematics. MP.8 Look for and express regularity in repeated reasoning.
MP.5 Use appropriate tools strategically.

Connections: See [S.ID.5](#)

Common Misconceptions: See [S.ID.5](#)

Explanations and Examples: S.ID.6

Create a scatter plot from two quantitative variables; identify the independent and dependent variables; and describe the relationship of the variables.

Describe the form, strength and direction of the relationship.

S.ID.6a – Determine when linear, quadratic, and exponential models should be used to represent a data set.

Use algebraic methods and technology to fit a linear, exponential or quadratic function to the data. Use the function to predict values.

Explain the meaning of the slope and y -intercept in context.

Explain the meaning of the growth rate and y -intercept in context.

Explain the meaning of the constant and coefficients in context.

S.ID.6b – Calculate a residual. Create and analyze a residual plot to determine whether the function is an appropriate fit.

S.ID.6c – Categorize data as linear or not. Write the equation of the line of best fit.

The residual in a regression model is the difference between the observed and the predicted y for some x (y the dependent variable and x the independent variable).

So, if we have a model $y = ax + b$, and a data point (x_i, y_i) the residual for this point is: $r_i = y_i - (ax_i + b)$.

Students may use spreadsheets, graphing calculators, and statistical software to represent data, describe how the variables are related, fit functions to data, perform regressions, and calculate residuals.

Examples:

- Measure the wrist and neck size of each person in your class and make a scatter plot. Find the least squares regression line. Calculate and interpret the correlation coefficient for this linear regression model. Graph the residuals and evaluate the fit of the linear equations.

Continued on next page

Explanations and Examples: S.ID.6

- The following data shows the age and average daily energy requirements for male children and teens.

Age	1	2	5	11	14	17
Daily Energy	1110	1300	1800	2500	2800	3000

Create a graph and find a linear function to fit the data. Using your function, what is the daily energy requirement for a male 15 years old? Would your model apply to an adult male? Explain your reasoning.

- Collect data on forearm length and height in a class. Plot the data and estimate a linear function for the data. Compare and discuss different student representations of the data and equations students discover.

Could the equation(s) be used to estimate the height for any person with a known forearm length? Why or why not?

Instructional Strategies: See [S.ID.5](#)

Statistics and Probability: Interpreting Categorical and Quantitative Data ★ **(S-ID)**

Cluster: *Interpret linear models.*

Standard: S.ID.7 Interpret the slope (rate of change) and the intercept (constant term) of a linear model in the context of the data. (★)

Suggested Standards for Mathematical Practice (MP):

MP.1 Make sense of problems and persevere in solving them.

MP.2 Reason abstractly and quantitatively.

MP.5 Use appropriate tools strategically.

MP.4 Model with mathematics.

MP.6 Attend to precision.

Connections: S.ID.7-9

Developing a measure of relationship between two quantitative variables was introduced in middle school.

The focus here is on the development of the correlation coefficient as a measure of how well the data fit the relationship. The important distinction between a statistical relationship and a cause-and-effect relationship arises in S.ID.9.

Explanations and Examples: S.ID.7

Explain the meaning of slope and y -intercept in terms of the units stated in the data and context of the situation.

Students may use spreadsheets or graphing calculators to create representations of data sets and create linear models.

Examples:

- Lisa lights a candle and records its height in inches every hour. The results recorded as (time, height) are: (0, 20), (1, 18.3), (2, 16.6), (3, 14.9), (4, 13.2), (5, 11.5), (7, 8.1), (9, 4.7), and (10, 3). Express the candle's height (h) as a function of time (t) and state the meaning of the slope and the intercept in terms of the burning candle.

Solution:

$$h = -1.7t + 20$$

Slope: The candle's height decreases by 1.7 inches for each hour it is burning.

Intercept: Before the candle begins to burn, its height is 20 inches,

- Collect power bills and graph the cost of electricity compared to the number of kilowatt hours used. Find a function that models the data and tell what the intercept and slope mean in the context of the problem.

Instructional Strategies: S.ID.7-9

In this cluster, the key is that two quantitative variables are being measured on the same subject. The paired data should be listed and then displayed in a scatterplot. If time is one of the variables, it usually goes on the horizontal axis. That which is being predicted goes on the vertical; the predictor variable is on the horizontal axis.

Continued on next page

Instructional Strategies: S.ID.7-9

Note that unlike a two-dimensional graph in mathematics, the scales of a scatterplot need not be the same, and even if they are similar (such as SAT Math and SAT Verbal), they still need not have the same spacing. So, visual rendering of slope makes no sense in most scatterplots, i.e., a 45 degree line on a scatterplot need not mean a slope of 1.

Often the interpretation of the intercept (constant term) is not meaningful in the context of the data. For example, this is the case when the zero point on the horizontal is of considerable distance from the values of the horizontal variable, or in some case has no meaning such as for SAT variables.

Noting that a correlated relationship between two quantitative variables is not causal (unless the variables are in an experiment) is a very important topic and a substantial amount of time should be spent on it.

Common Misconceptions: S.ID.7-9

Students may believe:

That a 45 degree line in the scatterplot of two numerical variables always indicates a slope of 1 which is the case only when the two variables have the same scaling. Because the scaling for many real-world situation varies greatly students need to be give opportunity to compare graphs of differing scale. Asking students questions like; What would this graph look like with a different scale or using this scale? Is essential in addressing this misconception.

That when two quantitative variables are related, i.e., correlated, that one causes the other to occur. Causation is not necessarily the case. For example, at a theme park, the daily temperature and number of bottles of water sold are demonstrably correlated, but an increase in the number of bottles of water sold does not cause the day's temperature to rise or fall.

Statistics and Probability: Interpreting Categorical and Quantitative Data ★ [\(S-ID\)](#)

Cluster: *Interpret linear models.*

Standard: S.ID.8 Compute (using technology) and interpret the correlation coefficient of a linear fit. (★)

Suggested Standards for Mathematical Practice (MP):

MP.4 Model with mathematics.

MP.6 Attend to precision.

MP.5 Use appropriate tools strategically.

Connections: See [S.ID.7](#)

Common Misconceptions: See [S.ID.7](#)

Explanations and Examples: S.ID.8

Explain that the correlation coefficient must be between -1 and 1 inclusive and explain what each of these values means.

Determine whether the correlation coefficient shows a weak positive, strong positive, weak negative strong negative, or no correlation.

Use the correlation coefficient to determine if a linear model is a good fit for the data (significant).

Students may use spreadsheets, graphing calculators and statistical software to represent data, describe how the variables are related, fit functions to data, perform regressions, and calculate residuals and correlation coefficients.

Examples:

- The correlation coefficient of a given data set is 0.97 . List three specific things this tells you about the data.
- Collect height, shoe-size, and wrist circumference data for each student. Determine the best way to display the data. Answer the following questions.
 - Is there a correlation between any two of the three indicators?
 - Is there a correlation between all three indicators?
 - What patterns and trends are apparent in the data?
 - What inferences can be made from the data?
- Hypothesize the correlation between two sets of related data. Gather data to support or refute your hypothesis.

Instructional Strategies: See [S.ID.7](#)

Have students enter data into graphing technology, calculate the regression equation and interpret what the correlation coefficient is telling about the data.

Statistics and Probability: Interpreting Categorical and Quantitative Data ★ [\(S-ID\)](#)

Cluster: *Interpret linear models.*

Standard: S.ID.9 Distinguish between correlation and causation. (★)

Suggested Standards for Mathematical Practice (MP):

MP.3 Construct viable arguments and critique the reasoning of others.

MP.4 Model with mathematics.

MP.6 Attend to precision.

Connections: See [S.ID.7](#)

Common Misconceptions: See [S.ID.7](#)

Explanations and Examples: S.ID.9

Understand and explain the difference between correlation and causation.

Understand and explain that a strong correlation does not mean causation.

Determine if statements of causation seem reasonable or unreasonable and justify reasoning.

Choose two variables that could be correlated because one is the cause of the other; defend and justify selection of variables.

Choose two variables that could be correlated even though neither variable could reasonably be considered to be the cause of the other; defend and justify selection of variables.

Some data leads observers to believe that there is a cause and effect relationship when a strong relationship is observed. Students should be careful not to assume that correlation implies causation. The determination that one thing causes another requires a controlled randomized experiment.

Examples:

- Diane did a study for a health class about the effects of a student's end-of-year math test scores on height. Based on a graph of her data, she found that there was a direct relationship between students' math scores and height. She concluded that "doing well on your end-of-course math tests makes you tall."
Is this conclusion justified? Explain any flaws in Diane's reasoning.

Instructional Strategies: See [S.ID.7](#)

Discuss data that has correlation but no causation (height vs. foot length).

Discuss data that has correlation and causation (number of M&Ms in a cup vs. weight of the cup).

Statistics and Probability: Making Inferences and Justifying Conclusions ★ [\(S-IC\)](#)

Cluster: *Understand and evaluate random processes underlying statistical experiments.*

Standard: S.IC.1 Understand statistics as a process for making inferences about population parameters based on a random sample from that population. (★)

Suggested Standards for Mathematical Practice (MP):

MP.2 Reason abstractly and quantitatively..

MP.4 Model with mathematics.

MP.6 Attend to precision.

Connections: S.IC.1-2

The four-step statistical process was introduced in Grade 6, with the recognition of statistical questions. At the high school level, students need to become proficient in all the steps of the statistical process.

Using simulation to estimate probabilities is a part of the Grade 7 curriculum as is initial understanding of using random sampling to draw inferences about a population.

Explanations and Examples: S.IC.1

Define populations, population parameter, random sample, and inference.

Explain why randomization is used to draw a sample that represents a population well.

Recognize that statistics involves drawing conclusions about a population based on the results obtained from a random sample of the population.

Example:

- From a class containing 12 girls and 10 boys, three students are to be selected to serve on a school advisory panel. Here are four different methods of making the selection.

I. Select the first three names on the class roll.

II. Select the first three students who volunteer.

III. Place the names of the 22 students in a hat, mix them thoroughly, and select three names from the mix.

IV. Select the first three students who show up for class tomorrow.

Which is the best sampling method, among these four, if you want the school panel to represent a fair and representative view of the opinions of your class?

Explain the weaknesses of the three you did not select as the best.

Solution:

Choice III is the best solution in terms of fairness because each of the other methods does not give equal chance of selection to all possible groups of three students. Explanations as to why the others are unfair may include comments such as the following:

I. Names beginning with the same letter may belong to the same family or the same ethnic group.

II. Volunteers may have special interest in a particular issue on which they want to focus.

IV. Prompt students perhaps, would be the more conscientious members of a panel, but they may not be typical of students in the class.

Continued on next page

Instructional Strategies: S.IC.1-2

Inferential statistics based on Normal probability models is a topic for Advanced Placement Statistics (e.g., t -tests). The idea here is that all students understand that statistical decisions are made about populations (parameters in particular) based on a random sample taken from the population and the observed value of a sample statistic (note that both words start with the letter “s”). A population parameter (note that both words start with the letter “p”) is a measure of some characteristic in the population such as the population proportion of American voters who are in favor of some issue, or the population mean time it takes an Alka Seltzer tablet to dissolve.

As the statistical process is being mastered by students, it is instructive for them to investigate questions such as “If a coin spun five times produces five tails in a row, could one conclude that the coin is biased toward tails?” One way a student might answer this is by building a model of 100 trials by experimentation or simulation of the number of times a truly fair coin produces five tails in a row in five spins. If a truly fair coin produces five tails in five tosses 15 times out of 100 trials, then there is no reason to doubt the fairness of the coin. If, however, getting five tails in five spins occurred only once in 100 trials, then one could conclude that the coin is biased toward tails (if the coin in question actually landed five tails in five spins).

A powerful tool for developing statistical models is the use of simulations. This allows the students to visualize the model and apply their understanding of the statistical process.

Provide opportunities for students to clearly distinguish between a population parameter which is a constant, and a sample statistic which is a variable.

Common Misconceptions: S.IC.1-2

Students may believe:

That population parameters and sample statistics are one in the same, e.g., that there is no difference between the population mean which is a constant and the sample mean which is a variable.

Making decisions is simply comparing the value of one observation of a sample statistic to the value of a population parameter, not realizing that a distribution of the sample statistic needs to be created.

Statistics and Probability: Making Inferences and Justifying Conclusions ★ [\(S-IC\)](#)

Cluster: *Understand and evaluate random processes underlying statistical experiments.*

Standard: S.IC.2 Decide if a specified model is consistent with results from a given data-generating process, e.g., using simulation. *For example, a model says a spinning coin falls heads up with probability 0.5. would a result of 5 tails in a row cause you to question the model?* (★)

Suggested Standards for Mathematical Practice (MP):

MP.1 Make sense of problems and persevere in solving them. MP.6 Attend to precision.
MP.2 Reason abstractly and quantitatively. MP.7 Look for and make use of structure.
MP.3 Construct viable arguments and critique the reasoning of others. MP.4 Model with mathematics.
MP.5 Use appropriate tools strategically. MP.8 Look for and express regularity in repeated reasoning.

Connections: See [S.IC.1](#)

Common Misconceptions: See [S.IC.1](#)

Explanations and Examples: S.IC.2

Include comparing theoretical and empirical results to evaluate the effectiveness of a treatment.

Explain how well and why a sample represents the variable of interest from a population.

Demonstrate understanding of the different kinds of sampling methods.

Design simulations of random sampling, assign digits in appropriate proportions for events, carry out the simulation using random number generators and random number tables and explain the outcomes in context of the population and the known proportions.

Possible data-generating processes include (but are not limited to): Flipping coins, spinning spinners, rolling a number cube, and simulations using the random number generators.

Students may use graphing calculators, spreadsheet programs, or applets to conduct simulations and quickly perform large numbers of trials.

The law of large numbers states that as the sample size increases, the experimental probability will approach the theoretical probability. Comparison of data from repetitions of the same experiment is part of the model building verification process.

Examples:

- Have multiple groups flip coins. One group flips a coin 5 times, one group flips a coin 20 times, and one group flips a coin 100 times. Which group's results will most likely approach the theoretical probability?

Continued on next page

Explanations and Examples: S.IC.2

- A random sample of 100 students from a specific high school resulted in 45% of them favoring a plan to implement block scheduling. Is it plausible that a majority of the students in the school actually favor the block schedule? Simulation can help answer the questions.

The accompanying plot shows a simulated distribution of sample proportions for samples of size 100 from a population in which 50% of the students favor the plan, and another distribution from a population in which 60% of the students favor the plan. (Each simulation contains 200 runs.)

- What do you conclude about the plausibility of a population proportion of 0.50 when the sample proportion is only 0.45?

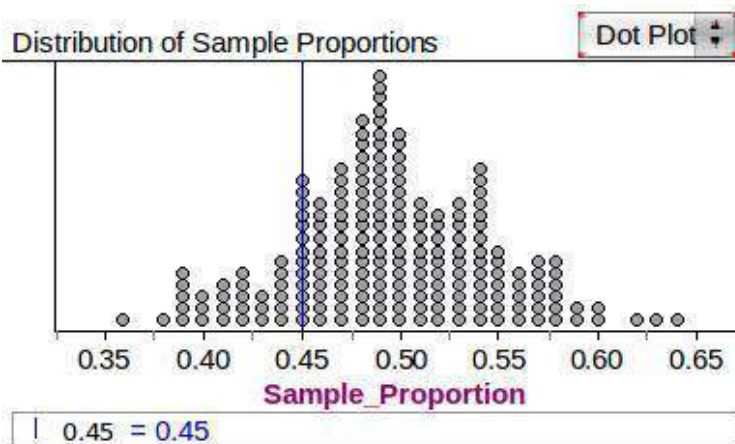

- What about the plausibility of 0.60 for the population proportion?

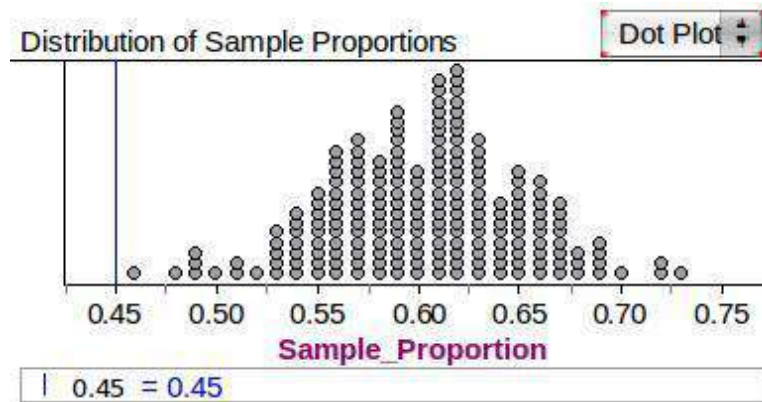

Solution:

- When sampling 100 students from a population in which 50% of the students favor the plan, the data indicates that a sample proportion of 45% (or less) is quite likely to occur. Thus, a population proportion of 0.50 is plausible, given the observed sample result.
- When sampling 100 students from a population in which 60% of the students favor the plan, the data indicates that a sample proportion of 45% (or less) is quite unlikely. Thus, a population proportion of 0.60 is not plausible, given the observed sample result.

Instructional Strategies: See [S.IC.1](#)

Statistics and Probability: Making Inferences and Justifying Conclusions ★ **(S-IC)**

Cluster: *Make inferences and justify conclusions from sample surveys, experiments and observational studies.*

Standard: S.IC.3 Recognize the purposes of and differences among sample surveys, experiments, and observational studies; explain how randomization relates to each. (★)

Suggested Standards for Mathematical Practice (MP):

MP.2 Reason abstractly and quantitatively.

MP.4 Model with mathematics.

MP.3 Construct viable arguments and critique the reasoning of others.

MP.6 Attend to precision.

Connections: S.IC.3-6

In earlier grades, students are introduced to different ways of collecting data and use graphical displays and summary statistics to make comparisons. These ideas are revisited with a focus on how the way in which data is collected determines the scope and nature of the conclusions that can be drawn from that data. The concept of statistical significance is developed informally through simulation as meaning a result that is unlikely to have occurred solely as a result of random selection in sampling or random assignment in an experiment.

Using simulation to estimate probabilities is a part of the Grade 7 curriculum, as is introductory understanding of using random sampling to draw inferences about a population.

Explanations and Examples: S.IC.3

Identify situations as either sample survey, experiment, or observational study. Discuss the appropriateness of each one's use in contexts with limiting factors. Describe the purposes and differences of each.

Design or evaluate sample surveys, experiments and observational studies with randomization. Discuss the importance of randomization in these processes.

Students should be able to explain techniques/applications for randomly selecting study subjects from a population and how those techniques/applications differ from those used to randomly assign existing subjects to control groups or experimental groups in a statistical experiment.

In statistics, and observational study draws inferences about the possible effect of a treatment on subjects, where the assignment of subjects into a treated group versus a control group is outside the control of the investigator (for example, observing data on academic achievement and socio-economic status to see if there is a relationship between them). This is in contrast to controlled experiments, such as randomized controlled trials, where each subject is randomly assigned to a treated group or a control group before the start of the treatment.

Example:

- Students in a high school mathematics class decided that their term project would be a study of the strictness of the parents or guardians of students in the school. Their goal was to estimate the proportion of students in the school who thought of their parents or guardians as "strict". They do not have time to interview all 1000 students in the school, so they plan to obtain data from a sample of students.

Continued on next page

Explanations and Examples: S.IC.3

- a. Describe the parameter of interest and a statistic the students could use to estimate the parameter.
- b. Is the best design for this study a sample survey, an experiment, or an observational study? Explain your reasoning.
- c. The students quickly realized that, as there is no definition of “strict”, they could not simply ask a student, “Are your parents or guardians strict?” Write three questions that could provide objective data related to strictness.
- d. Describe an appropriate method for obtaining a sample of 100 students, based on your answer in part (a) above.

Solution: (This task connects to standard S.IC.1)

(a) The parameter of interest is the proportion of all 1000 students at the school who have strict parents or guardians. A possible statistic to estimate this parameter is the proportion of students in the collected sample who have strict parents or guardians.

(b) The best design would be a sample survey, because we are interested in estimating a population parameter, namely, the proportion of all parents at the school who are "strict". It is less time consuming and costly to take a random sample of students than to interview all students at the school.

(c) Answers will vary. "Do your parents require you to do your homework before you can meet with your friends?" "Do your parents require that you be home before 11pm on a weekend night?" "Do your parents limit your mobile phone time?"

(d) Answers will vary. A list of all students should be obtained from the principal's office and a subset of student names should be taken from the list by randomly sampling without replacement. For example, the students could read triplets of digits from a random number table so that 000 represents the first student on the principal's list and 999 the last. The students would begin at an arbitrary point in the table and then write down consecutive triplets until they had obtained the desired sample size. If a three-digit number is repeated, then they should skip that triplet and write down the next. Alternatively, a computer could be asked to take a random sample without replacement from the digits 1 through 1000.

Instructional Strategies: S.IC.3-6

This cluster is designed to bring the four-step statistical process to life and help students understand how statistical decisions are made. The mastery of this cluster is fundamental to the goal of creating a statistically literate citizenry. Students will need to use all of the data analysis, statistics, and probability concepts covered to date to develop a deeper understanding of inferential reasoning.

Students learn to devise plans for collecting data through the three primary methods of data production: surveys, observational studies, and experiments. Randomization plays various key roles in these methods. Emphasize that randomization is not a haphazard procedure, and that it requires careful implementation to avoid biasing the analysis. In surveys, the sample selected from a population needs to be representative; taking a random sample is generally what is done to satisfy this requirement. In observational studies, the sample needs to be representative of the population as a whole to enable generalization from sample to population. The best way to satisfy this is to use random selection in choosing the sample.

Students like to ask each other questions, but constructing meaningful, unbiased survey questions is not easy. Begin by critiquing published surveys before having students design their own.

Continued on next page

Instructional Strategies: S.IC.3-6

In comparative experiments between two groups, random assignment of the treatments to the subjects is essential to avoid damaging problems when separating the effects of the treatments from the effects of some other variable, called confounding. In many cases, it takes a lot of thought to be sure that the method of randomization correctly produces data that will reflect that which is being analyzed. For example, in a two-treatment randomized experiment in which it is desired to have the same number of subjects in each treatment group, having each subject toss a coin where Heads assigns the subject to treatment A and Tails assigned the subject to treatment B will not produce the desired random assignment of equal-size groups.

The advantage that experiments have over surveys and observational studies is that one can establish causality with experiments.

Standard 4 addresses estimation of the population proportion parameter and the population mean parameter. Data need not come from just a survey to cover this topic. A margin-of-error formula cannot be developed through simulation, but students can discover that as the sample size is increased, the empirical distribution of the sample proportion and the sample mean tend toward a certain shape (the Normal distribution), and the standard error of the statistics decreases (i.e. the variation) in the models becomes smaller. The actual formulas will need to be stated.

Standard 5 addresses testing whether some characteristic of two paired or independent groups is the same or different by the use of resampling techniques. Conclusions are based on the concept of p-value. Resampling procedures can begin by hand but typically will require technology to gather enough observations for which a p-value calculation will be meaningful.

Use a variety of devices as appropriate to carry out simulations: number cubes, cards, random digit tables, graphing calculators, computer programs.

Common Misconceptions: S.IC.3-6

Students may believe:

That collecting data is easy; asking friends for their opinions is fine in determining what everyone thinks.

That causal effect can be drawn in surveys and observational studies, instead of understanding that causality is in fact a property of experiments.

That inference from sample to population can be done only in experiments. They should see that inference can be done in sampling and observational studies if data are collected through a random process.

Statistics and Probability: Making Inferences and Justifying Conclusions ★ [\(S-IC\)](#)

Cluster: *Make inferences and justify conclusions from sample surveys, experiments and observational studies.*

Standard: S.IC.4 Use data from a sample survey to estimate a population mean or proportion; develop a margin of error through the use of simulation models for random sampling. (★)

Suggested Standards for Mathematical Practice (MP):

MP.1 Make sense of problems and persevere in solving them. MP.5 Use appropriate tools strategically.
MP.3 Construct viable arguments and critique the reasoning of others.
MP.4 Model with mathematics. MP.6 Attend to precision.

Connections: See [S.IC.3](#)

Common Misconceptions: See [S.IC.3](#)

Explanations and Examples: S.IC.4

For S.IC.4-5 focus on the variability of results from experiments. Focus on statistics as a way of dealing with, not eliminating, inherent randomness.

Calculate the sample mean and proportion.

Use sample means and sample proportions to estimate population values.

Defend the statement, “The population mean or proportion is close to the sample mean or proportion when the sample is randomly selected and large enough to represent the population well.”

Infer that the population mean or proportion is equal to the sample mean or proportion and conduct simulation to determine which sample results are typical of this model and which results are considered outliers (*possible, but unexpected*).

Choose an appropriate margin of error for the sample mean or proportion and create a confidence interval based on the results of the simulation conducted.

Determine how often the true population mean or proportion is within the margin of error of each sample mean or proportion.

Pose a question regarding the mean or proportion of a population, use statistical techniques to estimate the parameter, and design an appropriate product to summarize the process and report the estimate. Explain what the results mean about variability in a population and use results to calculate the error for these estimates.

Students may use computer generated simulation models based upon the results of sample surveys to estimate population statistics and margins of error.

Continued on next page

Explanations and Examples: S.IC.4

- Is normal body temperature the same for men and women? Medical researchers interested in this question collected data from a large number of men and women. Random samples from that data are recorded in the table below.
 - a. Use a 95% confidence interval to estimate the mean body temperature of men.
 - b. Use a 95% confidence interval to estimate the mean body temperature of women.
 - c. Find the margin of error for the men and for the women.
 - d. Which margin of error is larger? Why is it larger?

Body Temperature (°F)	
Male	Female
96.9	97.8
97.4	98.0
97.8	98.2
97.8	98.2
97.9	98.6
98.0	98.8
98.1	98.8
98.6	99.2
98.8	99.4

Instructional Strategies: See [S.IC.3](#)

Statistics and Probability: Making Inferences and Justifying Conclusions ★ [\(S-IC\)](#)

Cluster: *Make inferences and justify conclusions from sample surveys, experiments and observational studies.*

Standard: S.IC.5 Use data from a randomized experiment to compare two treatments; use simulations to decide if differences between parameters are significant. (★)

Suggested Standards for Mathematical Practice (MP):

- MP.1 Make sense of problems and persevere in solving them. MP.6 Attend to precision.
MP.3 Construct viable arguments and critique the reasoning of others.
MP.4 Model with mathematics. MP.8 Look for and express regularity in repeated reasoning.
MP.5 Use appropriate tools strategically.

Connections: See [S.IC.3](#)

Common Misconceptions: See [S.IC.3](#)

Explanations and Examples: S.IC.5

For S.IC.4-5 focus on the variability of results from experiments. Focus on statistics as a way of dealing with, not eliminating, inherent randomness.

Calculate the sample mean and standard deviation of the two treatment groups and the difference of the means.

Conduct a simulation for each treatment group using the sample results as the parameters for the distributions.

Calculate the difference of means for each simulation and represent those differences in a histogram.

Use the results of the simulation to create a confidence interval for the difference of means.

Use the confidence interval to determine if the parameters are significantly different based on the original difference of means.

Students may use computer generate simulation models to decide how likely it is that observed differences in a randomized experiment are due to chance.

Treatment is a term used in the context of an experimental design to refer to any prescribed combination of values of explanatory variables. For example, one wants to determine the effectiveness of weed killer. Two equal pieces of land in a neighborhood are treated, one with a placebo and one with weed killer to determine whether there is a significant difference in effectiveness in eliminating weeds.

Example:

- Using a completely randomized design, 20 students counted the number of times they blinked their eyes and the number of breaths they took in one minute. The data is shown in the table.

Compute the mean and standard deviation for both the number of breaths and number of blinks.

What are the similarities and differences in the results?

Number of Breaths	Number of Blinks
10	27
9	28
12	20
16	30
11	23
14	22
20	31
12	29
13	30
14	20

Instructional Strategies: See [S.IC.3](#)

Statistics and Probability: Making Inferences and Justifying Conclusions ★ [\(S-IC\)](#)

Cluster: *Make inferences and justify conclusions from sample surveys, experiments and observational studies.*

Standard: S.IC.6 Evaluate reports based on data. (★)

Suggested Standards for Mathematical Practice (MP):

MP.1 Make sense of problems and persevere in solving them. MP.4 Model with mathematics.
MP.2 Reason abstractly and quantitatively. MP.5 Use appropriate tools strategically.
MP.3 Construct viable arguments and critique the reasoning of others. MP.6 Attend to precision.
MP.7 Look for and make use of structure. MP.8 Look for and express regularity in repeated reasoning.

Connections: See [S.IC.3](#)

Common Misconceptions: See [S.IC.3](#)

Explanations and Examples: S.IC.6

Read and explain in context data from outside reports.

Identify the variables as quantitative or categorical.

Describe how the data was collected.

Indicate any potential biases or flaws.

Identify inferences the author of the report made from sample data.

Write or present a summary of a data-based report addressing the sampling techniques used, inferences made, and any flaws or biases.

Explanations can include but are not limited to sample size, biased survey sample, interval scale, unlabeled scale, uneven scale, and outliers that distort the line-of-best-fit. In a pictogram the symbol scale used can also be a source of distortion.

As a strategy, collect reports published in the media and ask students to consider the source of the data, the design of the study, and the way the data are analyzed and displayed.

Example:

- A reporter used the two data sets below to calculate the mean housing price in Kansas as \$629,000. Why is this calculation not representative of the typical housing price in Kansas?
 - Wichita area {1.2 million, 242,000, 265,500, 140,000, 281,000, 265,000, 211,000}
 - Overland Park homes {5 million, 154,000, 250,000, 250,000, 200,000, 160,000, 190,000}

Instructional Strategies: See [S.IC.3](#)

Statistics and Probability: Conditional Probability and the Rules of Probability ★ (S-CP)

Cluster: *Understand independence and conditional probability and use them to interpret data.*

Standard: S.CP.1 Describe events as subsets of a sample space (the set of outcomes) using characteristics (or categories) of the outcomes, or as unions, intersections, or complements of other events (“or,” “and,” “not”). (★)

Suggested Standards for Mathematical Practice (MP):

MP.1 Make sense of problems and persevere in solving them. MP.6 Attend to precision.
MP.2 Reason abstractly and quantitatively. MP.7 Look for and make use of structure.
MP.4 Model with mathematics.

Connections: S.IC.1-5

Beginning work with categorical variables and two-way tables occurs in Grade 8. It is likely that these standards will need to be revisited on a deeper level.

Explanations and Examples: S.CP.1

Build on work with two-way tables from S.ID.5 to develop understanding of conditional probability and independence. Define a sample space and events within the sample space.

Establish events as subsets of a sample space.

Use correct set notation, with appropriate symbols, to identify sets and subsets.

Define union, intersection, and complement.

Draw Venn diagrams that show relationships between sets within a sample space.

The **intersection** of two sets A and B is the set of elements that are common to both set A and set B . It is denoted by $A \cap B$ and is read “ A intersection B ”.

- $A \cap B$ in the diagram is $\{1, 5\}$
- This means: BOTH/AND

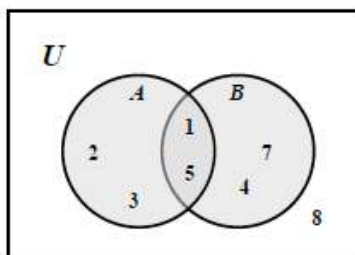

The **union** of two sets A and B is the set of elements, which are in A or in B , or in both. It is denoted by $A \cup B$, and is read “ A union B ”.

- $A \cup B$ in the diagram is $\{1, 2, 3, 4, 5, 7\}$
- This means: EITHER/OR/ANY
- Could be both

The **complement** of the set $A \cup B$ is the set of elements that are members of the universal set U but are not in $A \cup B$. It is denoted by $(A \cup B)'$

- $(A \cup B)'$ in the diagram is $\{8\}$

Continued on next page

Explanations and Examples: S.CP.1

Examples:

- Describe the event that the summing two rolled dice is larger than 7 **and** even, and contrast it with the event that the sum is larger than 7 **or** even.
- Create a Venn diagram to display the information in the table. Describe the set of students who have a curfew but don't do chores as a subset of the group.

	Curfew: Yes	Curfew: No	Total
Chores: Yes	13	5	18
Chores: No	12	3	15
Total	25	8	

Instructional Strategies: S.CP.1-5

The **Standard for Mathematical Practice**, *precision* is important for working with conditional probability. Attention to the definition of an event along with the writing and use of probability function notation are important requisites for communication of that precision. For example: Let A: Female and B: Survivor, then $P(A|B) =$. The use of a vertical line for the conditional "given" is not intuitive for students and they often confuse the events $B|A$ and $A|B$. Moreover, they often find identifying a conditional difficult when the problem is expressed in words in which the word "given" is omitted. For example, find the probability that a female is a survivor. The standard ***Make sense of problems and persevere in solving them*** also should be employed so students can look for ways to construct conditional probability by formulating their own questions and working through them such as is suggested in standard 4 above. Students should learn to employ the use of Venn diagrams as a means of finding an entry into a solution to a conditional probability problem.

It will take a lot of practice to master the vocabulary of "or," "and," "not" with the mathematical notation of union (\cup), intersection (\cap), and whatever notation is used for complement.

The independence of two events is defined in Standard 2 using the intersection. It is far more intuitive to introduce the independence of two events in terms of conditional probability (stated in Standard 3), especially where calculations can be performed in two-way tables.

The Standards in this cluster deliberately do not mention the use of tree diagrams, the traditional way to treat conditional probabilities. Instead, probabilities of conditional events are to be found using a two-way table wherever possible. Using a two-way table begins with calculation of marginal probabilities. Conditional probabilities and determination of independent events follow. However, tree diagrams may be a helpful tool for some students. The difficulty is realizing that the second set of branches are conditional probabilities.

There are many good problems that can appeal to students' sensitivities of fairness and justice in society. Students can formulate their questions that concern how certain characteristics of their own identity groups are viewed by society and understand how conditional probability is often misunderstood by society as whole.

Common Misconceptions: S.CP.1-5

Students may believe:

That multiplying across branches of a tree diagram has nothing to do with conditional probability.

That independence of events and mutually exclusive events are the same thing.

Statistics and Probability: Conditional Probability and the Rules of Probability ★ [\(S-CP\)](#)

Cluster: *Understand independence and conditional probability and use them to interpret data.*

Standard: S.CP.2 Understand that two events A and B are independent if the probability of A and B occurring together is the product of their probabilities, and use this characterization to determine if they are independent. (★)

Suggested Standards for Mathematical Practice (MP):

MP.1 Make sense of problems and persevere in solving them. MP.6 Attend to precision.
MP.2 Reason abstractly and quantitatively. MP.7 Look for and make use of structure.
MP.3 Construct viable arguments and critique the reasoning of others.
MP.4 Model with mathematics.

Connections: See [S.CP.1](#)

Common Misconceptions: See [S.CP.1](#)

Explanations and Examples: S.CP.2

Define and identify independent events. Explain properties of Independence and Conditional Probabilities.

Use appropriate probability notation for individual events as well as their intersection (joint probability).

Calculate probabilities for events, including joint probabilities, using various methods (e.g., Venn diagrams, frequency table).

Compare the product of probabilities for individual events ($P(A) \cdot P(B)$) with their joint probability ($P(A \cap B)$).

Understand that independent events satisfy the relationship $P(A) \cdot P(B) = P(A \cap B)$.

Predict if two events are independent, explain reasoning and check.

Examples:

- When rolling two number cubes:
 - What is the probability of rolling a sum that is greater than 7?
 - What is the probability of rolling a sum that is odd?
 - Are the events, rolling a sum greater than 7, and rolling a sum that is odd, independent?
Justify your response.
- Roll a pair of dice 100 times and keep track of the outcomes. Find pairs of events that are independent and pairs that are not. Justify your conclusions. (For example, the probability of rolling doubles and the probability of rolling 7 vs. the probability of rolling doubles and the probability of rolling a sum that is less than 4).

Instructional Strategies: See [S.CP.1](#)

Convert frequencies from a Venn diagram or a two-way frequency table into probabilities with correct notation.

Generate a two-way frequency table to describe characteristics of your class (e.g. gender and eye color) and use the table to determine if eye color and gender are independent.

Compare experimental results to theoretical (long run) probabilities.

Statistics and Probability: Conditional Probability and the Rules of Probability ★ (S-CP)

Cluster: *Understand independence and conditional probability and use them to interpret data.*

Standard: S.CP.3 Understand the conditional probability of A given B as $P(A \text{ and } B)/P(B)$, and interpret independence of A and B as saying that the conditional probability A given B is the same as the probability of A , and the conditional probability of B given A is the same as the probability of B . (★)

Suggested Standards for Mathematical Practice (MP):

MP.1 Make sense of problems and persevere in solving them. MP.6 Attend to precision.
MP.2 Reason abstractly and quantitatively. MP.7 Look for and make use of structure.
MP.4 Model with mathematics.

Connections: See [S.CP.1](#)

Common Misconceptions: See [S.CP.1](#)

Explanations and Examples: S.CP.3

Define dependent events and conditional probability.

Explain that conditional probability is the probability of an event occurring given the occurrence of some other event and give examples that illustrate conditional probabilities.

Explain that for two events A and B , the probability of event A occurring given the occurrence of event B is:

$$P(A|B) = \frac{P(A \text{ and } B)}{P(B)} \text{ and give examples to show how to use the formula.}$$

Determine if two events are independent and justify the conclusion.

Examples:

- Given the following Venn diagram, determine whether events A and B are independent.

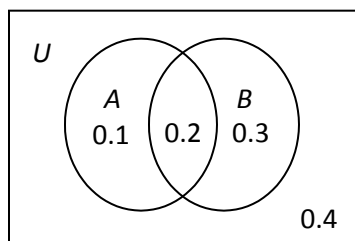

- A die is thrown twice. Determine the probability that the sum of the rolls is less than 4 given that:
 - At least one of the rolls is a 1.
 - The first roll is a 1.
- Is participation in sports independent of participation in the arts?

Instructional Strategies: See [S.CP.1](#)

Statistics and Probability: Conditional Probability and the Rules of Probability ★ (S-CP)

Cluster: *Understand independence and conditional probability and use them to interpret data.*

Standard: S.CP.4 Construct and interpret two-way frequency tables of data when two categories are associated with each object being classified. Use the two-way table as a sample space to decide if events are independent and to approximate conditional probabilities. *For example, collect: data from a random sample of students in your school on their favorite subject among math, science, and English. Estimate the probability that a randomly selected student from your school will favor science given that the student is in tenth grade. Do the same for other subjects and compare the results.* (★)

Suggested Standards for Mathematical Practice (MP):

MP.1 Make sense of problems and persevere in solving them. MP.4 Model with mathematics.
MP.2 Reason abstractly and quantitatively. MP.5 Use appropriate tools strategically.
MP.3 Construct viable arguments and critique the reasoning of others. MP.6 Attend to precision.
MP.7 Look for and make use of structure. MP.8 Look for and express regularity in repeated reasoning.

Connections: See [S.CP.1](#)

Common Misconceptions: See [S.CP.1](#)

Explanations and Examples: S.CP.4

Determine when a two-way frequency table is an appropriate display for a set of data.

Collect data from a random sample.

Construct a two-way frequency table for the data using the appropriate categories for each variable.

Calculate probabilities from the table. Use probabilities from the table to evaluate independence of two variables.

Pose a question for which a two-way frequency is appropriate, use statistical techniques to sample the population, and design an appropriate product to summarize the process and report the results.

Students may use spreadsheets, graphing calculators, and simulations to create frequency tables and conduct analyses to determine if events are independent or determine approximate conditional probabilities.

Examples:

- Collect data from a random sample of students in your school on their favorite subject among math, science, history, and English. Estimate the probability that a randomly selected student from your school will favor science given that the student is in tenth grade. Do the same for other subjects and compare the results.
- A two-way frequency table is shown below displaying the relationship between age and baldness. We took a sample of 100 male subjects and determined who is or is not bald. We also recorded the age of the male subjects by categories.

Bald	Age		Total
	Younger than 45	45 or older	
No	35	11	46
Yes	24	30	54
Total	59	41	100

What is the probability that a man from the sample is bald, given that he is under 45?

Are the events independent? Justify your answer.

Continued on next page

Explanations and Examples: S.CP.4

- Jaime randomly surveyed some students at his school to see what they thought of a possible increase to the length of the school day. The results of his survey are shown in the table below.

Lengthening School Day Survey

Grade	In Favor	Opposed	Undecided
9	12	6	9
10	15	3	11
11	8	12	10
12	5	16	9

Part A

A newspaper reporter will randomly select a Grade 11 student from this survey to interview. What is the probability that the student selected is opposed to lengthening the school day?

Part B

The newspaper reporter would also like to interview a student in favor of lengthening the school day. If a student in favor is randomly selected, what is the probability that this student is also from Grade 11?

Solution:

Part A 0.4 (or equivalent)

Part B 0.2 (or equivalent)

- Select two categorical variables and conduct research to answer various probability questions and determine independence. Write a “newsworthy” article for the school newspaper that interprets the interesting relationships between the events.

Instructional Strategies: See [S.CP.1](#)

Statistics and Probability: Conditional Probability and the Rules of Probability ★ [\(S-CP\)](#)

Cluster: *Understand independence and conditional probability and use them to interpret data.*

Standard: S.CP.5 Recognize and explain the concepts of conditional probability and independence in everyday language and everyday situations. *For example, compare the chance of having lung cancer if you are a smoker with the chance of being a smoker if you have lung cancer.* (★)

Suggested Standards for Mathematical Practice (MP):

MP.1 Make sense of problems and persevere in solving them. MP.6 Attend to precision.
MP.4 Model with mathematics. MP.8 Look for and express regularity in repeated reasoning.

Connections: See [S.CP.1](#)

Common Misconceptions: See [S.CP.1](#)

Explanations and Examples: S.CP.5

Illustrate the concept of conditional probability using everyday examples of dependent events.

Illustrate the concept of independence using everyday examples of independent events.

Interpret conditional probabilities and independence in context.

Examples:

- What is the probability of drawing a heart from a standard deck of cards on a second draw, given that a heart was drawn on the first draw and not replaced? Are these events independent or dependent?
- At your high school the probability that a student takes a Business class and Spanish is 0.062. The probability that a student takes a Business class is 0.43. What is the probability that a student takes Spanish given that the student is taken a Business class?
- Use the data given in the table. Is owning a smart phone independent from grade level?

	Own smart phone	Do not own smart phone
10 th Grade	204	170
11 th Grade	192	160
12 th Grade	198	165

Instructional Strategies: See [S.CP.1](#)

Statistics and Probability: Conditional Probability and the Rules of Probability ★ **(S-CP)**

Cluster: *Use the rules of probability to compute probabilities of compound events in a uniform probability model.*

Standard: S.CP.6 Find the conditional probability of A given B as the fraction of B 's outcomes that also belong to A , and interpret the answer in terms of the model. (★)

Suggested Standards for Mathematical Practice (MP):

MP.1 Make sense of problems and persevere in solving them. MP.5 Use appropriate tools strategically.
MP.4 Model with mathematics. MP.7 Look for and make use of structure.

Connections: S.CP.6-7

Probability is introduced in Grade 7. The concepts of independence and conditional probability are the extended topics in domain S-CP.

Explanations and Examples: S.CP.6

Calculate conditional probabilities using the definition: ‘the conditional probability of A given B as the fraction of B 's outcomes that also belong to A ’.

Interpret the probability based on the context of the given problem.

Students could use graphing calculators, simulations, or applets to model probability experiments and interpret the outcomes.

Examples:

- A teacher gave her class two quizzes. 30% of the class passed both quizzes and 60% of the class passed the first quiz. What percent of those who passed the first quiz also passed the second quiz?
- A local restaurant asked 1000 people, “Did you cook dinner last night?” The results of this survey are shown in the table below.

“Did You Cook Dinner Last Night?”		
	Male	Female
Yes	115	480
No	327	78

Determine what the probability is of a person chosen at random from the 1000 surveyed.

- cooked dinner last night
- was a male and did not cook dinner
- was a male
- was a female and cooked dinner last night

Continued on next page

Instructional Strategies: S.CP.6-7

Identifying that a probability is conditional when the word “given” is not stated can be very difficult for students. For example, if a balanced tetrahedron with faces 1, 2, 3, 4 is rolled twice, what is the probability that the sum is prime (A) of those that show a 3 on at least one roll (B)? Whether what is asked for is $P(A \text{ and } B)$, $P(A \text{ or } B)$, or $P(A|B)$ can be problematic for students. Showing the outcomes in a Venn Diagram may be useful. The calculation to find the probability that the sum is prime (A) given at least one roll shows 3 (B) is to count the elements of B by listing them if possible, namely in this example, there are 7 paired outcomes (31, 32, 33, 34, 13, 23, 43). Of those 7 there are 4 whose sum is prime (32, 34, 23, 43). Hence in the long run, 4 out of 7 times of rolling a fair tetrahedron twice, the sum of the two rolls will be a prime number under the condition that at least one of its rolls shows the digit 3.

Note that if listing outcomes is not possible, then counting the outcomes may require a computation technique involving permutations or combinations.

In the above example, if the question asked were what is the probability that the sum of two rolls of a fair tetrahedron is prime (A) or at least one of the rolls is a 3 (B), then what is being asked for is $P(A \text{ or } B)$ which is denoted as $P(A \cup B)$ in set notation. Again, it is often useful to appeal to a Venn Diagram in which A consists of the pairs: 11, 12, 14, 21, 23, 32, 34, 41, 43; and B consists of 13, 23, 33, 43, 31, 32, 34. Adding $P(A)$ and $P(B)$ is a problem as there are duplicates in the two events, namely 23, 32, 34, and 43. So $P(A \text{ or } B)$ is $9/16 + 7/16 - 4/16 = 12/16$ or $3/4$, so $3/4$ th of the time, the result of rolling a fair tetrahedron twice will result in the sum being prime, or at least one of the rolls showing a 3, or perhaps both will occur.

Common Misconceptions: S.CP.6-7

Students may believe:

That the probability of A or B is always the sum of the two events individually.

That the probability of A and B is the product of the two events individually, not realizing that one of the probabilities may be conditional.

Statistics and Probability: Conditional Probability and the Rules of Probability ★ [\(S-CP\)](#)

Cluster: *Use the rules of probability to compute probabilities of compound events in a uniform probability model.*

Standard: S.CP.7 Apply the Addition Rule, $P(A \text{ or } B) = P(A) + P(B) - P(A \text{ and } B)$, and interpret the answer in terms of the model. (★)

Suggested Standards for Mathematical Practice (MP):

MP.1 Make sense of problems and persevere in solving them. MP.6 Attend to precision.
MP.4 Model with mathematics. MP.7 Look for and make use of structure.
MP.5 Use appropriate tools strategically.

Connections: S.CP.6-7

Probability is introduced in Grade 7. The concepts of independence and conditional probability are the extended topics in domain S-CP.

Explanations and Examples: S.CP.7

Identify two events as disjoint (mutually exclusive). Calculate probabilities using the Addition Rule.

Interpret the probability of unions and intersections based on the context of the given problem.

Students could use graphing calculators, simulations, or applets to model probability experiments and interpret the outcomes.

Examples:

- In a math class of 32 students, 18 boys and 14 are girls. On a unit test, 5 boys and 7 girls made an A grade. If a student is chosen at random from the class, what is the probability of choosing a girl or an A student?

Instructional Strategies: See [S.CP.6](#)

Common Misconceptions: S.CP.6-7

Students may believe:

That the probability of A or B is always the sum of the two events individually.

That the probability of A and B is the product of the two events individually, not realizing that one of the probabilities may be conditional.

TABLE 1. Common addition and subtraction situations.⁶

	Result Unknown	Change Unknown	Start Unknown
Add to	Two bunnies sat on the grass. Three more bunnies hopped there. How many bunnies are on the grass now? $2 + 3 = ?$	Two bunnies were sitting on the grass. Some more bunnies hopped there. Then there were five bunnies. How many bunnies hopped over to the first two? $2 + ? = 5$	Some bunnies were sitting on the grass. Three more bunnies hopped there. Then there were five bunnies. How many bunnies were on the grass before? $? + 3 = 5$
Take from	Five apples were on the table. I ate two apples. How many apples are on the table now? $5 - 2 = ?$	Five apples were on the table. I ate some apples. Then there were three apples. How many apples did I eat? $5 - ? = 3$	Some apples were on the table. I ate two apples. Then there were three apples. How many apples were on the table before? $? - 2 = 3$

	Total Unknown	Addend Unknown	Both Addends Unknown ¹
Put Together/ Take Apart²	Three red apples and two green apples are on the table. How many apples are on the table? $3 + 2 = ?$	Five apples are on the table. Three are red and the rest are green. How many apples are green? $3 + ? = 5, 5 - 3 = ?$	Grandma has five flowers. How many can she put in her red vase and how many in her blue vase? $5 = 0 + 5, 5 = 5 + 0$ $5 = 1 + 4, 5 = 4 + 1$ $5 = 2 + 3, 5 = 3 + 2$

	Difference Unknown	Bigger Unknown	Smaller Unknown
Compare³	(“How many more?” version): Lucy has two apples. Julie has five apples. How many more apples does Julie have than Lucy? (“How many fewer?” version): Lucy has two apples. Julie has five apples. How many fewer apples does Lucy have than Julie? $2 + ? = 5, 5 - 2 = ?$	(Version with “more”): Julie has three more apples than Lucy. Lucy has two apples. How many apples does Julie have? (Version with “fewer”): Lucy has 3 fewer apples than Julie. Lucy has two apples. How many apples does Julie have? $2 + 3 = ?, 3 + 2 = ?$	(Version with “more”): Julie has three more apples than Lucy. Julie has five apples. How many apples does Lucy have? (Version with “fewer”): Lucy has 3 fewer apples than Julie. Julie has five apples. How many apples does Lucy have? $5 - 3 = ?, ? + 3 = 5$

¹These *take apart* situations can be used to show all the decompositions of a given number. The associated equations, which have the total on the left of the equal sign, help children understand that the = sign does not always mean *makes or results in* but always does mean *is the same number as*.

²Either addend can be unknown, so there are three variations of these problem situations. Both Addends Unknown is a productive extension of this basic situation especially for small numbers less than or equal to 10.

³For the Bigger Unknown or Smaller Unknown situations, one version directs the correct operation (the version using *more* for the bigger unknown and using *less* for the smaller unknown). The other versions are more difficult.

⁶Adapted from Box 2-4 of Mathematics Learning in Early Childhood, National Research Council (2009, pp. 32, 33).

TABLE 2. Common multiplication and division situations.⁷

	Unknown Product	Group Size Unknown ("How many in each group?" Division)	Number of Groups Unknown ("How many groups?" Division)
	$3 \times 6 = ?$	$3 \times ? = 18$ and $18 \div 3 = ?$	$? \times 6 = 18$ and $18 \div 6 = ?$
Equal Groups	<p>There are 3 bags with 6 plums in each bag. How many plums are there in all?</p> <p><i>Measurement example.</i> You need 3 lengths of string, each 6 inches long. How much string will you need altogether?</p>	<p>If 18 plums are shared equally into 3 bags, then how many plums will be in each bag?</p> <p><i>Measurement example.</i> You have 18 inches of string, which you will cut into 3 equal pieces. How long will each piece of string be?</p>	<p>If 18 plums are to be packed 6 to a bag, then how many bags are needed?</p> <p><i>Measurement example.</i> You have 18 inches of string, which you will cut into pieces that are 6 inches long. How many pieces of string will you have?</p>
Arrays,⁴ Area⁵	<p>There are 3 rows of apples with 6 apples in each row. How many apples are there?</p> <p><i>Area example.</i> What is the area of a 3 cm by 6 cm rectangle?</p>	<p>If 18 apples are arranged into 3 equal rows, how many apples will be in each row?</p> <p><i>Area example.</i> A rectangle has area 18 square centimeters. If one side is 3 cm long, how long is a side next to it?</p>	<p>If 18 apples are arranged into equal rows of 6 apples, how many rows will there be?</p> <p><i>Area example.</i> A rectangle has area 18 square centimeters. If one side is 6 cm long, how long is a side next to it?</p>
Compare	<p>A blue hat costs \$6. A red hat costs 3 times as much as the blue hat. How much does the red hat cost?</p> <p><i>Measurement example.</i> A rubber band is 6 cm long. How long will the rubber band be when it is stretched to be 3 times as long?</p>	<p>A red hat costs \$18 and that is 3 times as much as a blue hat costs. How much does a blue hat cost?</p> <p><i>Measurement example.</i> A rubber band is stretched to be 18 cm long and that is 3 times as long as it was at first. How long was the rubber band at first?</p>	<p>A red hat costs \$18 and a blue hat costs \$6. How many times as much does the red hat cost as the blue hat?</p> <p><i>Measurement example.</i> A rubber band was 6 cm long at first. Now it is stretched to be 18 cm long. How many times as long is the rubber band now as it was at first?</p>
General	$a \times b = ?$	$a \times ? = p$ and $p \div a = ?$	$? \times b = p$ and $p \div b = ?$

⁴The language in the array examples shows the easiest form of array problems. A harder form is to use the terms rows and columns: The apples in the grocery window are in 3 rows and 6 columns. How many apples are in there? Both forms are valuable.

⁵Area involves arrays of squares that have been pushed together so that there are no gaps or overlaps, so array problems include these especially important measurement situations.

⁷The first examples in each cell are examples of discrete things. These are easier for students and should be given before the measurement examples.

TABLE 3. The properties of operations. Here a , b and c stand for arbitrary numbers in a given number system. The properties of operations apply to the rational number system, the real number system, and the complex number system.

<i>Associative property of addition</i>	$(a + b) + c = a + (b + c)$
<i>Commutative property of addition</i>	$a + b = b + a$
<i>Additive identity property of 0</i>	$a + 0 = 0 + a = a$
<i>Existence of additive inverses</i>	For every a there exists $-a$ so that $a + (-a) = (-a) + a = 0$.
<i>Associative property of multiplication</i>	$(a \times b) \times c = a \times (b \times c)$
<i>Commutative property of multiplication</i>	$a \times b = b \times a$
<i>Multiplicative identity property of 1</i>	$a \times 1 = 1 \times a = a$
<i>Existence of multiplicative inverses</i>	For every $a \neq 0$ there exists $1/a$ so that $a \times 1/a = 1/a \times a = 1$.
<i>Distributive property of multiplication over addition</i>	$a \times (b + c) = a \times b + a \times c$

TABLE 4. The properties of equality. Here a , b and c stand for arbitrary numbers in the rational, real, or complex number systems.

<i>Reflexive property of equality</i>	$a = a$
<i>Symmetric property of equality</i>	If $a = b$, then $b = a$.
<i>Transitive property of equality</i>	If $a = b$ and $b = c$, then $a = c$.
<i>Addition property of equality</i>	If $a = b$, then $a + c = b + c$.
<i>Subtraction property of equality</i>	If $a = b$, then $a - c = b - c$.
<i>Multiplication property of equality</i>	If $a = b$, then $a \times c = b \times c$.
<i>Division property of equality</i>	If $a = b$ and $c \neq 0$, then $a \div c = b \div c$.
<i>Substitution property of equality</i>	If $a = b$, then b may be substituted for a in any expression containing a .

TABLE 5. The properties of inequality. Here a , b and c stand for arbitrary numbers in the rational or real number systems.

Exactly one of the following is true: $a < b$, $a = b$, $a > b$.
If $a > b$ and $b > c$ then $a > c$.
If $a > b$, then $b < a$.
If $a > b$, then $-a < -b$.
If $a > b$, then $a \pm c > b \pm c$.
If $a > b$ and $c > 0$, then $a \times c > b \times c$.
If $a > b$ and $c < 0$, then $a \times c < b \times c$.
If $a > b$ and $c > 0$, then $a \div c > b \div c$.
If $a > b$ and $c < 0$, then $a \div c < b \div c$.

Cognitive Rigor Matrix/Depth of Knowledge (DOK) The Common Core State Standards require high-level cognitive demand asking students to demonstrate deeper conceptual understanding through the application of content knowledge and skills to new situations and sustained tasks. For each Assessment Target the depth(s) of knowledge (DOK) that the student needs to bring to the item/task will be identified, using the Cognitive Rigor Matrix shown below.

Depth of Thinking (Webb)+ Type of Thinking (Revised Bloom)	DOK Level 1 Recall & Reproduction	DOK Level 2 Basic Skills & Concepts	DOK Level 3 Strategic Thinking & Reasoning	DOK Level 4 Extended Thinking
Remember	<ul style="list-style-type: none"> Recall conversions, terms, facts 			
Understand	<ul style="list-style-type: none"> Evaluate an expression Locate points on a grid or number on number line Solve a one-step problem Represent math relationships in words, pictures, or symbols 	<ul style="list-style-type: none"> Specify, explain relationships Make basic inferences or logical predictions from data/observations Use models/diagrams to explain concepts Make and explain estimates 	<ul style="list-style-type: none"> Use concepts to solve non-routine problems Use supporting evidence to justify conjectures, generalize, or connect ideas Explain reasoning when more than one response is possible Explain phenomena in terms of concepts 	<ul style="list-style-type: none"> Relate mathematical concepts to other content areas, other domains Develop generalizations of the results obtained and the strategies used and apply them to new problem situations
Apply	<ul style="list-style-type: none"> Follow simple procedures Calculate, measure, apply a rule (e.g., rounding) Apply algorithm or formula Solve linear equations Make conversions 	<ul style="list-style-type: none"> Select a procedure and perform it Solve routine problem applying multiple concepts or decision points Retrieve information to solve a problem Translate between representations 	<ul style="list-style-type: none"> Design investigation for a specific purpose or research question Use reasoning, planning, and supporting evidence Translate between problem & symbolic notation when not a direct translation 	<ul style="list-style-type: none"> Initiate, design, and conduct a project that specifies a problem, identifies solution paths, solves the problem, and reports results
Analyze	<ul style="list-style-type: none"> Retrieve information from a table or graph to answer a question Identify a pattern/trend 	<ul style="list-style-type: none"> Categorize data, figures Organize, order data Select appropriate graph and organize & display data Interpret data from a simple graph Extend a pattern 	<ul style="list-style-type: none"> Compare information within or across data sets or texts Analyze and draw conclusions from data, citing evidence Generalize a pattern Interpret data from complex graph 	<ul style="list-style-type: none"> Analyze multiple sources of evidence or data sets
Evaluate			<ul style="list-style-type: none"> Cite evidence and develop a logical argument Compare/contrast solution methods Verify reasonableness 	<ul style="list-style-type: none"> Apply understanding in a novel way, provide argument or justification for the new application
Create	<ul style="list-style-type: none"> Brainstorm ideas, concepts, problems, or perspectives related to a topic or concept 	<ul style="list-style-type: none"> Generate conjectures or hypotheses based on observations or prior knowledge and experience 	<ul style="list-style-type: none"> Develop an alternative solution Synthesize information within one data set 	<ul style="list-style-type: none"> Synthesize information across multiple sources or data sets Design a model to inform and solve a practical or abstract situation